

**1MT0003 系列隔爆型三相异步电动机**  
**1MT0003 Series Gas Explosion-proof**  
**Three-phase Asynchronous Motor**

**安装与维护手册**

**Installation and Maintenance Manual**

**茵梦达电机（中国）有限公司**

**Innomotics Standard**

**Motors Ltd.**

2026.05

# 目录

1 安全信息 .....	3
1.1 五条安全原则 .....	3
1.2 合格人员 .....	3
1.3 使用电气设备时的电磁场 .....	3
1.4 在危险区域使用 .....	4
2 使用前的准备 .....	4
2.1 应用范围 .....	4
2.2 冷却方式 .....	4
2.3 安装结构形式 .....	5
2.4 运输和保存 .....	5
3 安装 .....	6
3.1 准备安装区域 .....	6
3.2 安装 .....	6
3.3 电气连接 .....	7
3.4 连接后的检查 .....	9
4 启动 .....	10
4.1 启动前的检查 .....	10
4.2 试运行 .....	10
5 运行和维护 .....	11
5.1 运行中的安全提示 .....	11
5.2 运行 .....	12
5.3 检查和维护 .....	12
5.4 变频器的应用.....	14
5.5 隔爆尺寸.....	20
English version .....	21

# 1 安全信息

## 1.1 五条安全原则

开展作业时，为保障人身安全和避免财产损失，请始终遵守安全注意事项和下面符合 EN50110-1 “在无电压状态下工作”的五项安全规程。开始作业前请按照以下顺序实施五项安全规程。

- (1) 断电，包括断开辅助电路，例如防潮加热带等。
- (2) 确保不会意外通电。
- (3) 确认设备上已无电压。
- (4) 接地并短接。
- (5) 遮盖或隔离邻近的带电部件。

结束作业后按照相反的顺序取消上述措施。

## 1.2 合格人员

只允许由专业人员调试和操作设备。本文中涉及的专业人员必须满足以下前提条件：

- 必须接受过相关培训且具备相应经验，能够发现职责范围内的风险，避免发生危险。
- 必须是由负责人委任的相应人员进行作业。

## 1.3 使用电气设备时的电磁场

电气设备可干扰电子设备。电气设备在运行中会产生电磁场。在电机附近逗留可能会使医疗植入体，如心脏起搏器等，出现危及生命的故障。磁性或电子数据存储设备可能会发生数据丢失。

- 禁止佩戴心脏起搏器的人员在电机附近逗留。
- 采取适当措施，如设置标识、封锁工作区域、张贴安全须知和警示标志等，为在设备周围工作的人员提供充分的保护和提醒，防止其受到伤害。
- 请遵守所在地区的安全和劳保护规定。
- 请不要让磁性或电子数据存储设备靠近电机。

本电机符合 GB755 (IEC/EN60034-1) 标准，在按照规定使用时满足关于电磁兼容性的要求。

## 1.4 在危险区域使用

在爆炸性环境中使用的电气设备必须由合格人员按照现行有效的规定进行安装、调试和操作。

---

### 说明

关于爆炸性环境中的电气设备及其运行的基本要求可查阅标准 GB 3836.15 (IEC/EN60079-14)。

---

设备使用者应咨询当地主管部门，评估现场环境条件和设备操作风险，以确定必要的监控措施，并将这些措施制定为规定。在任何条件下都必须遵守这些规定。由于现场条件各有不同，电机制造商无法提供普遍适用的建议。

---

### 说明

关于电气设备及爆炸性环境的评估方法，可查阅系列标准 GB/T3836 (IEC/EN60079)。

---

如果电机获得了第三方认证，则表明电机符合其中所规定的技术数据和特殊条件，应在调试前查看证书。

使用防爆认证带“X”标记的防爆电机时，对于隔爆型“db 或 d”电机，只能在遵守制造商设计说明的情况下才能维修该产品。不允许按照 GB/T3836.2 (IEC/EN60079-1) 中的标准值进行维修。

## 2 使用前的准备

### 2.1 应用范围

1MT0003 系列隔爆型三相异步电动机的设计和制造符合标准 GB/T3836.1《爆炸性环境 - 第 1 部分：设备通用要求》(IEC/EN60079-0) 和 GB/T3836.2《爆炸性环境 - 第 2 分：由隔爆外壳“d”保护的设备》(IEC/EN60079-1)。适用于 II 类 B 级爆炸性气体存在的工作环境。

该系列电机符合 GB18613《中小型三相异步电动机能效限定值及能效等级》中规定的能效等级 3 级 (IEC/EN60034-30 中的 IE3 能效等级) 要求，具体规格电机的能耗指标参见电机上的铭牌。

电机工作环境条件为海拔不超过 1000 米，环境温度范围-20°C~+40°C。

涉及电压频率：

220V/380V 50Hz、220V 50Hz、230V 50Hz、380V 50Hz

230V/400V 50Hz、400V 50Hz、415V 50Hz、440V 50Hz

240V/415V 50Hz、460V 50Hz、480V 50Hz、500V 50Hz

380V/660V 50Hz、575V 50Hz、660V 50Hz、690V 50Hz、400V/690V 50Hz

220V/380V 60Hz、110V 60Hz、220V 60Hz、230V 60Hz、380V 60Hz

230V/400V 60Hz、400V 60Hz、415V 60Hz、440V 60Hz

380V/660V 60Hz、460V 60Hz、480V 60Hz、500V 60Hz

400V/690V 60Hz、575V 60Hz、660V 60Hz、690V 60Hz

该产品外壳防护等级：IP55。

防爆标志：Ex db IIB T4 Gb

电机型谱：

1MT0003-0DA2, 1MT0003-0DA3, 1MT0003-0DB2, 1MT0003-0DB3, 1MT0003-0DC3,  
1MT0003-0EA0, 1MT0003-0EA4, 1MT0003-0EB0, 1MT0003-0EB4, 1MT0003-0EC0,  
1MT0003-0EC4, 1MT0003-1AA4, 1MT0003-1AB4, 1MT0003-1AB5, 1MT0003-1AC4,  
1MT0003-1BA2, 1MT0003-1BB2, 1MT0003-1BC2, 1MT0003-1CA0, 1MT0003-1CA1,  
1MT0003-1CB0, 1MT0003-1CB2, 1MT0003-1CC0, 1MT0003-1CC2, 1MT0003-1CC3,  
1MT0003-1CD0, 1MT0003-1CD2, 1MT0003-1DA2, 1MT0003-1DA3, 1MT0003-1DA4,  
1MT0003-1DB2, 1MT0003-1DB4, 1MT0003-1DC2, 1MT0003-1DC4, 1MT0003-1DD2,  
1MT0003-1DD3, 1MT0003-1DD4, 1MT0003-1EA2, 1MT0003-1EB2, 1MT0003-1EB4,  
1MT0003-1EC4, 1MT0003-1ED4, 1MT0003-2AA4, 1MT0003-2AA5, 1MT0003-2AB4,  
1MT0003-2AC4, 1MT0003-2AC5, 1MT0003-2AD5, 1MT0003-2BA2, 1MT0003-2BB0,  
1MT0003-2BB2, 1MT0003-2BC2, 1MT0003-2BD0, 1MT0003-2BD2, 1MT0003-2CA2,  
1MT0003-2CB2, 1MT0003-2CC2, 1MT0003-2CD2, 1MT0003-2DA0, 1MT0003-2DA2,  
1MT0003-2DB0, 1MT0003-2DB2, 1MT0003-2DC0, 1MT0003-2DC2, 1MT0003-2DD0,  
1MT0003-2DD2, 1MT0003-3AA0, 1MT0003-3AA2, 1MT0003-3AA5, 1MT0003-3AA6,  
1MT0003-3AA7, 1MT0003-3AB0, 1MT0003-3AB2, 1MT0003-3AB5, 1MT0003-3AB6,  
1MT0003-3AB7, 1MT0003-3AC0, 1MT0003-3AC2, 1MT0003-3AC5, 1MT0003-3AC6,  
1MT0003-3AD0, 1MT0003-3AD2, 1MT0003-3AD5, 1MT0003-3AD6, 1MT0003-3AE0,  
1MT0003-3AE2, 1MT0003-3AE5, 1MT0003-3AE6, 1MT0003-3BA2, 1MT0003-3BA3,  
1MT0003-3BA5, 1MT0003-3BA6, 1MT0003-3BB2, 1MT0003-3BB3, 1MT0003-3BB5,  
1MT0003-3BB6, 1MT0003-3BC2, 1MT0003-3BC3, 1MT0003-3BC4, 1MT0003-3BC5,  
1MT0003-3BC6, 1MT0003-3BD2, 1MT0003-3BD3, 1MT0003-3BD5, 1MT0003-3BD6,  
1MT0003-3BE2, 1MT0003-3BE3, 1MT0003-3BE4, 1MT0003-3BE5

## 2.2 冷却方式

电机标配冷却方式为自扇冷式，符合 GB1993 中的 IC411 冷却方式（IEC/EN60034-6）。如果使用带有独立驱动风扇的电机，冷却方式 IC416，请对电路进行设计以防止在独风扇未运行时接通并运行主电机。

**警告**

**电机过热**

如果不注意以下几点，可能会造成财产损失、重伤或死亡。

- 切勿阻碍通风。
- 防止临近机组的废气被电机风扇直接吸入。
- 对于进风口朝上的竖直安装的电机，应防止异物和水从进风口进入。
- 对于轴端朝上的竖直安装的电机，应防止液体沿轴端流入电机。

### 2.3 安装结构形式

电机的安装结构形式符合 GB/T997《旋转电机结构型式、安装型式及接线盒位置的分类（IM 代码）》（IEC/EN60034-7）。电机铭牌上表示出了其安装结构形式。

### 2.4 运输和保存

收货后立即检查货物是否与随附单证相一致。

- 立即向运输代理商报告任何明显的运输损坏。
- 如有明显缺失/不完整，应立即通知相应的茵梦达办事处。

注意

电机损坏

未按规定存放可能会损坏电机。

在极端气候条件下（如含盐和/或积尘、潮湿的环境），应采取适当的防护措施。

选择水平、稳固且干燥的存放位置。将电机、设备和包装箱放置在底架、大方木料或基座上，以防止地面湿气。防止电机陷入地下。防潮用的盖布或防雨布不得与所存放物品的表面接触。

应防止受极端天气的影响。存放位置应保持干燥、通风良好并且防尘、防冻、防撞、防止剧烈振动。

长期存放时（≥6个月），须对裸露的金属表面采取适当的防腐措施。

警告

密封材料损坏可能引发爆炸

在超出允许的环境温度下存放电机，可能导致密封材料因温度而损坏，导致密封失效。这可能让爆炸性气体和粉尘等异物进入电机，从而引发爆炸。这可能造成财产损失、重伤或死亡。

存放电机的环境条件：

允许的温度范围：-20°C~+50°C

允许的最大空气湿度：60%

对于环境温度、湿度或海拔有特殊要求的电机，其存放条件需遵守其它要求。此时请参考电机铭牌上对于环境条件的说明。

存放时间：

每月必须至少旋转电机轴 1 次，以避免振蚀。长期存放会降低轴承润滑脂的使用寿命。对于密封型轴承，在存放超过两年后，电机使用前应更换前后轴承；对于配备了再润滑装置的电机，在存放超过两年后，应向前后轴承注入新的润滑脂。可再润滑型轴承的润滑脂型号、加注油脂量和再润滑周期见电机铭牌。

## 3 安装

### 3.1 准备安装区域

电机安装的基础可以是金属底座，也可以是混凝土平台。基础应具有足够的强度与刚度来支撑电机。常用电机支承面的平面度要求如下：

机座号	平面度 (mm)
≤132	0.10
160	0.15
≥180	0.20

安装位置应避免长时间受强烈阳光直接照射、雨雪、冰雹的侵蚀。

于轴伸向下竖直安装的电机，应避免异物落入风扇罩；对于轴伸向上竖直安装的电机，应避免液体沿轴伸流入电机。

防爆电机只能在允许的环境中使用。

当安装螺栓头部与电机外圆面发生干涉时，请将电机吊离对接法兰盘面，先将螺栓穿过法兰安装孔，把螺栓拧至头部与电机不干涉，对接法兰盘，再拧紧安装螺栓。

### 3.2 安装

对轴伸上传动件（联轴器、齿轮、皮带轮等）进行拆装时，应使用合适的工具，必要时进行热套操作。请勿使用锤子或类似工具敲击。电机轴伸上允许施加的径向载荷和轴向载荷不得超过样本上规定的最大值。

由于机械部件制造公差及累积误差的存在，电机底脚平面与安装基础的接触面之间可能存在间隙。安装时应用塞尺测量此间隙，对于 $\geq 0.05\text{mm}$ 的间隙，应插入合适的填隙片。填隙片尺寸根据实际间隙大小配做。

#### 警告

##### 电机掉落

如果不注意以下几点，可能会造成财产损失、重伤或死亡。

- 起吊前确保吊环都已拧紧。
- 起吊时必须使用电机上所有吊环。
- 务必使用合格的吊装索具进行作业。

除非另行规定，通常需使用符合 *GB/T3098.1 (ISO898-1)* 中规定的强度等级至少为 8.8 的紧固件，以安全固定电机。

电机与被驱动设备间所需对中精度主要取决于整个电机传动系统的配置。对中时务必遵循联轴器制造商要求的对中精度。

电机转子是动平衡的。只能使用已钻好孔并校准过平衡的从动元件。只能使用合适的工具安装和拆卸从动元件。使用轴顶端的螺纹孔或用手推将从动元件一次性装入。不允许使用锤子敲打，否则会损坏轴承。

#### 警告

键可能抛出

如果不注意以下几点，可能会造成财产损失、重伤或死亡。

- 键仅在运输过程中被固定以防止脱落，如果电机在未安装从动元件时启动，则键可能会在运行期间被抛出。
- 请固定好无从动元件的轴伸上的键，防止键被抛出。

注：本产品试验时配用变频器型号为SINAMICS G120 PM240-2，电机使用时应配用该系列或相似的变频器。

### 3.3 电气连接

危险

危险电压

可能导致死亡、重伤或财产损失。

- 所有操作只能由合格的专业人员在静止的电机上进行。
- 断开电源并确保不会被意外接通，该要求同样针对辅助电路。
- 确认无电压！
- 在开始工作前进行可靠的保护线连接！
- 供电电网的电压、频率、波形等相对于额定值的偏差会导致温度升高，同时也会影响电磁兼容性。
- 通常情况下不允许运行未接地的电机。只在极少数情况下可短暂运行，例如排查故障时。

对于使用喇叭口型进线斗的接线盒，选择电缆时，电缆直径需与进线斗内橡胶密封圈的孔径相匹配。尺寸见下表。

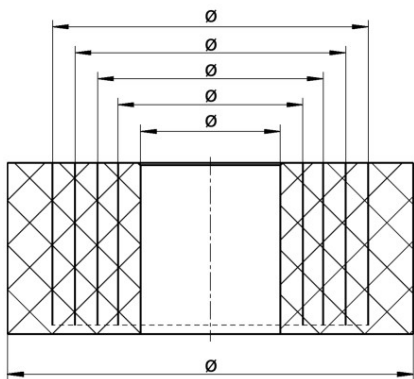

机座号	密封圈孔径 (mm)	电缆外径 (mm)
80~132	14	13
	20	19
	25	24
160~180	14	13
	20	19
	26	25
	31	30
	35	34
200~280	20	19
	26	25
	32	31
	38	37
	42	41
	31	30
	36	35
	45	44
	50	49

对于带辅助进线孔的接线盒，以及使用葛兰作为主电缆进线装置的接线盒，在接线盒上有用于安装葛兰的螺纹孔。螺纹孔尺寸和数量参考样本。电机出厂时这些螺纹孔由符合要求的阀盖密封。必须使用具有相应防爆区域（Zone分区）和防爆等级认证的并带有相应标识的葛兰、转接头和堵头。

在接线盒内进行接线时，需确保电缆与接线螺栓连接可靠。接线螺栓推荐的拧紧力矩参考下表。

接线螺栓规格		M4	M5	M6	M8	M10	M12	M16	M20
拧紧力矩 (Nm)	最小	1	1.6	2.5	5	8	13	25	42
	最大	1.2	2	3	6	10	15.5	30	52

若电机选配了温度传感器、防潮加热带等选件，其辅助电路的连接参考下面接线端子标识的说明。

电机绕组温度保护：

一组三芯 串联PTC		两组三芯 串联 PTC		三个单支 两线制 PT100				六个单支 两线制 PT100																					
第 15 位为 B		第 15 位为 C		第 15 位为 H				第 15 位为 J																					
2TP1	2TP2	1TP1	1TP2	2TP1	2TP2	1R1	1R2	2R1	2R2	3R1	3R2	1R1	1R2	2R1	2R2	3R1	3R2	4R1	4R2	5R1	5R2	6R1	6R2						
一个单支两线制 PT1000				两个单支两线制 PT1000				三个单支三线制 PT100																					
选项代码为 Q35				选项代码为 Q36				选项代码为 Q63																					
1R1		1R2		1R1		1R2		2R1		2R2		1R1		1R1		1R2		2R1		2R1		2R2		3R1		3R1		3R2	

六个单支三线制																	
PT100 选项代码 Q64																	
1R1	1R1	1R2	2R1	2R1	2R2	3R1	3R1	3R2	4R1	4R1	4R2	5R1	5R1	5R2	6R1	6R1	6R2

				两个单支三线制 PT100				两个双支三线制 PT100													
选项代码 Q72				选项代码 Q78				选项代码 Q79													
10R1	10R2	11R1	11R2	10R1	10R1	10R2	11R1	11R1	11R2	10R1	10R1	11R1	11R1	11R2	10R2	12R1	12R1	13R1	13R1	13R2	12R2

防潮加热带的接线端子编号为 1HE1 和 1HE2。

电机出厂时接线盒上的进线孔已使用符合要求的闷盖密封，接线后未使用的进线孔应保持其密封状态。接线盒内的接地和机壳外部的接地点必须有效接地。

### 3.4 连接后的检查

在完成接线后应检查以下几点：

- 接线盒中的电气连接已按照前面的说明完成，并以正确的力矩拧紧。
- 非绝缘组件之间的电气间隙。
- 不能有遗留的线头。
- 电机按照需要的旋转方向进行接线。

- 接线盒内必须保持整洁，不能有多余的零件和杂物。
- 所有密封件和接合面不能有损伤，且须保持干净。
- 接线盒中未使用的进线孔密封完好。
- 所有接地点都已正确接地。

## 4 启动

### 4.1 启动前的检查

在完成安装和连接后，在调试前请检查以下事项：

- 电机未受损。
- 电机按要求进行了安装和对中，被驱动组件已进行了正确的平衡和设置。
- 所有紧固件和电气连接件都已拧紧。
- 电机运行条件与技术文档中的规定一致，如爆炸环境类别、防护等级、环境温度等。
- 可移动部件，如联轴器等，可自由转动。
- 所有活动件和带电零件都进行了安全防护。

### 4.2 试运行

在安装电机后执行一次试运行：

- (1) 首先空载启动电机，检查电机旋转方向。
- (2) 空载正常时，给电机连接负载。
- (3) 在试运行期间检查并记录以下数据：
  - 检查运转时的噪声和振动情况。
  - 记录电压、电流和功率值。
  - 尽量使用可用的测量设备，检查轴承和绕组的温度。
- (4) 如果电机运行不平稳或发出异响，应立即关闭电机，并在电机惯性停转过程中排查故障原因：
  - 如果断开电源后噪声或振动明显改善，则说明是电磁方面的原因。
  - 如果断开电源后没有改善，则说明是机械方面的原因。可能的原因包括电机或负载设备不平衡，机组未充分对中，电机和系统发生共振。
- (5) 如果电机使用独立驱动风扇，则应在试运行时检查独立风扇的转向。

## 5 运行和维护

### 5.1 运行中的安全提示

---

#### 危险 危险电压

可能导致死亡、重伤或财产损失。

电气设备带有危险电压，如果接触设备表面、端子等部位，可能存在触电危险。

---

#### 警告

##### 运行期间的故障

运行过程中的异常状况表示电机可能出现了故障。这些故障可能导致财产损失、重伤或死亡。请注意以下故障征兆：

- 异常高功率消耗
  - 异常高温
  - 异常噪声
  - 异常振动
  - 异常气味
  - 监控装置发出的响应
- 

#### 注意

##### 电机损坏或轴承寿命缩短

- 务必要遵守允许的振动值，避免不平稳的工作环境和冲击，以避免电机或轴承损坏。
  - 务必要遵守样本上允许的轴向径向载荷。
  - 使用变频器驱动时，采取措施减小轴承电流。
- 

#### 注意

##### 冷凝水引起的腐蚀危险

电机温度或环境温度的变化可能造成电机内部出现冷凝水。如果电机带有防潮加热带，请确保在关闭电机后，防潮加热带被接通。

---

#### 注意

##### 电机过热

如果电机带有防潮加热带，请确保在启动电机前，防潮加热带停止工作。

---

若电机装配圆柱滚子轴承，空载运行时无径向预紧力，轴承易发生打滑，轴承噪声大。打滑初期，会在轴承滚道及滚动体上产生明显的粘着及拖尾痕迹，建议缩短空载运行时间或增加一定的径向预紧力。

## 5.2 运行

请尽可能在空载时启动电机并检查运转噪声。使用可用的测量设备，检查电机运行时的温度和振动。

---

### 注意

#### 直连运行的电机出现过载

除了反作用力矩，启动时间还主要受转动惯量的影响。启动时，电机的电流会达到额定电流的数倍。这会导致电机过热，电机可能被损坏。因此启动时应注意以下几点：

- 请遵循产品样本或订货文档中涉及的极限值或启动条件。
  - 监控每次启动时间以检查是否出现异常。
- 

若电机有独立驱动风扇，在关闭电机后，请不要立即关闭独立风扇。请等待直至电机冷却后再关闭独立风扇。这可避免余热积聚。

若电机长时间停机（超过 1 个月），应每月运行一次，或至少转动转子一次。

若电机停机时间超过 12 个月，请采取适当的防腐蚀、包装及干燥措施，否则电机可能因环境影响而损坏。并在再次开机前执行第 5 章中的检查和试运行。

## 5.3 检查和维护

---

### 危险

#### 静电可引发爆炸

可能导致死亡、重伤或财产损失。

清洁时，塑料部件可能产生静电并引燃爆炸性介质，这可能会导致爆炸。

- 确保不在爆炸性环境中进行清洁。
  - 清洁非金属部件时，避免静电积聚。
  - 请勿使用压缩空气进行清洁。
- 

在新电机运行约 500 小时或最晚一年后，请进行首次检查：

- 电机是否保持规定的电气特性。
- 轴承温度是否在允许范围内。
- 电机是否运行平稳，没有发出更大噪声。
- 电机安装基座是否出现裂缝和凹陷。

根据系统本身的特殊条件，可能还要完成其它的检查项目。

---

建议在电机运行 16000 小时或最晚两年后，进行例行检查：

- 电机是否保持规定的电气特性。
- 轴承温度是否在允许范围内。
- 电机是否运行平稳，没有发出更大噪声。

- 电机安装基座是否出现裂缝和凹陷。
- 电机的对中是否在允许的公差范围内。
- 所有机械和电气连接的紧固件都保持拧紧状态。
- 所有等电位连接、接地连接和屏蔽层的位置都正确并正常接触。
- 绕组的绝缘电阻足够大。
- 电缆、密封件、绝缘件的情况良好且没有变色现象。

电机按照样本上所规定的最大载荷值运转时，轴承寿命至少为20000小时。对于不受轴向径向载荷的电机，其轴承寿命至少为 40000 小时。请务必按照电机铭牌或技术文档中规定的润滑脂型号、加注油脂量和润滑周期对轴承进行润滑。加注润滑脂时应旋转电机轴以使润滑脂均匀分布。

使用防爆认证带“X”标记的防爆电机时，对于隔爆型“db 或 d”电机，只能在遵守制造商设计说明的情况下才能维修该产品。不允许按照 GB/T3836.2 (IEC/EN60079-1) 中的标准值进行维修。

#### REACH 法规第 33 条的规定

该产品的一个或多个组成物中含有高关注物质候选清单中的以下物质超过

0.1%：•CAS 编号 7439-92-1，铅

基于现有信息，在规范化使用的条件下，包括废弃处理，该物质不会产生风险。

## 5.4 变频器应用



转矩不稳定的负载（如活塞式压缩机负载），必然会导致非正弦电流，该电流的谐波会对系统造成影响，产生过多干扰。

### 电磁兼容性

当变频器驱动电机时，电磁干扰的程度取决于变频器的类型（种类，IGBT 数量，干扰控制措施及制造商）、布线、距离以及应用需求。

在设计和应用阶段必须参考变频器制造商关于电磁兼容性的安装指导。



如果使用变频器驱动电机，转速超过电机额定转速时，必须考虑对电机的机械零部件及传动联接件的影响。  
更多内容，请参考IEC 60034-1。

### 噪声，温升和振动

电机在变频运行时，电机噪声、温升将会有所增加。

变频应用时，可能会由于转速高于额定转速，电机机械振动加大，从而使机械运转的平稳性发生变化。这样也会导致轴承和润滑脂的寿命降低。

变频使用时，为了避免轴电流造成电机轴承损坏，推荐选用绝缘轴承选项（选项号L27）。

电机频率与转矩范围参照下表：

机座号	IC411		IC416	
	频率范围 (Hz)	转矩范围(Nm)	频率范围 (Hz)	转矩范围(Nm)
0D	3-100	1.5-5.5	3-85	2.5-6.0
0E	3-100	3.0~11	3-85	5.0~12
1A	3-100	6.0~19	3-85	10~20
1B	3-100	8.0~25	3-80	13~27
1C	3-100	10~50	3-70	15~55
1D	3-100	20~100	3-70	35~110
1E	3-100	40~140	3-70	70~150
2A	3-100	55~200	3-70	95~215
2B	3-85	95-270	3-70	145~295
2C	3-80	115~360	3-70	175~390
2D	3-75	155~540	3-70	240~585
3A	3-65	230~1320	3-65	350~1420
3B	3-65	460~2385	3-60	700~2580

电机在变频器上工作时FS315~355采用绝缘轴承

如果在低压变频器上运行电机，则在非驱动端会安装一个绝缘轴承和一个带有绝缘支座的转速编码器（选件）。

请遵循电机铭牌上有关轴承绝缘及允许的跨接的说明。

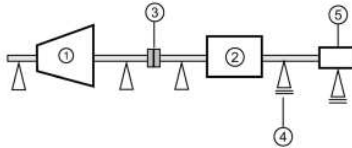

①负载机械 ②电机 ③联轴器 ④绝缘轴承 ⑤绝缘转速计

单轴驱动的示意图

### 注意！

轴承损坏不允许跨接轴承绝缘层。如有电流通过，可能会对轴承造成损坏。

- ◆ 在后续的安装作业中，如安装自动润滑系统或非绝缘型振荡接收器，请勿跨接轴承绝缘层。
- ◆ 若有需要，请联系服务中心

### 降低轴承电流

必须全面仔细的评估电机、变频器和负载机器构成的整体系统，才可以确实避免轴承电流造成的损害。

- 除通过实心保护地电缆对电机进行接地外，在高频范围内还需使用扁平铜芯编织电缆或高频绞线电缆进行低阻抗接地。需通过较大的接触面积连接这些电缆。由于集肤效应，实心铜电缆不适合用于高频接地。
- 使用对称结构的屏蔽电缆将电机接线连接在变频器上。由多根细导线组成的编织屏蔽层必须具有良好的导电性能。由铜线或铝线织成的屏蔽网较为合适。电缆屏蔽层应在电机和变频器这两端进行连接，未屏蔽的电缆头应尽可能短。

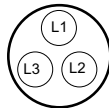

铜质或铝制同心电缆屏蔽层

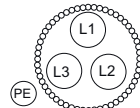
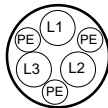

钢制铠装

- 保持屏蔽电缆两端的平面接触面的面积较大，以确保较好的排出高频电流。电缆屏蔽层应 360° 搭接在电机外壳以及变频器的保护接地母排上，如有：
  - 电机侧：进线处使用 EMC 格兰头
  - 变频器侧：EMC 屏蔽卡圈
- 在整个系统中安装性能良好的针对高频电流的低阻抗网状接地系统。
- 在电机、变频器和工作机之间没有电位差。
  - 在线盒和电机外壳上的高频接地点之间使用等电位电缆。
  - 在电机外壳和变频器的保护接地母排之间使用单独的高频等电位电缆。
  - 在电机外壳和负载机器之间使用单独的高频等电位电缆。
- 在变频器输出端上使用共模滤波器（磁环）。Innomotics 销售伙伴负责滤波器的选型设计。
- 使用输出滤波器来限制升压。输出滤波器可以减少输出电压中的谐波含量。
- 安装电机电抗器。

变频器的使用不在本文档中说明。请一并遵循变频器选型规定。

---

## 5.5 隔爆尺寸图

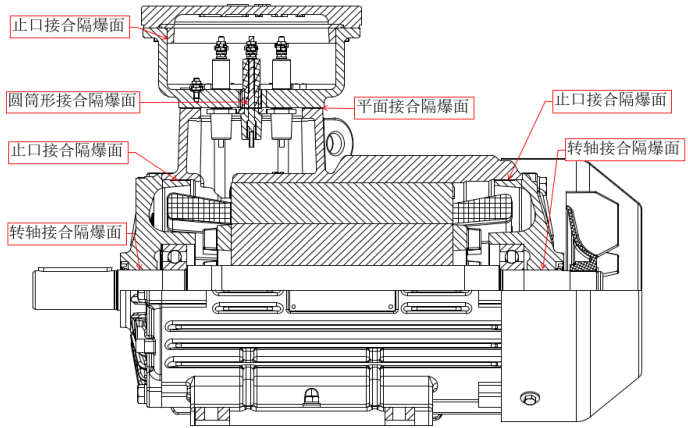

FS80-132

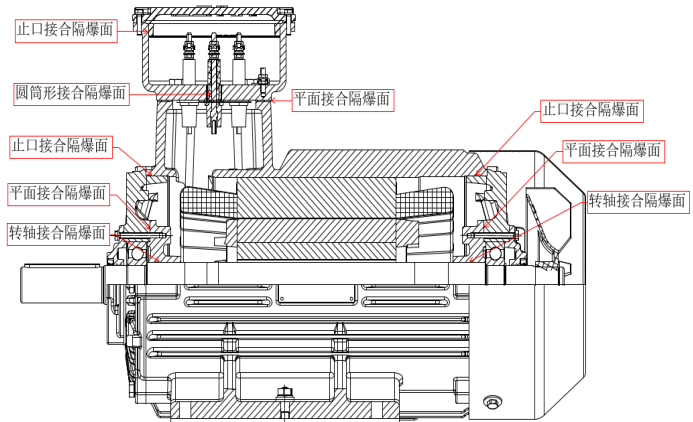

FS160-355

备注：若隔爆接合面损坏，不允许修理，必须更换零部件。



# Content

1 Safety information .....	20
1.1 The five safety rules .....	20
1.2 Qualified personnel .....	20
1.3 Electromagnetic fields when operating electric machines .....	20
1.4 Operating in hazardous area .....	21
2 Preparation before using .....	21
2.1 Application scope .....	21
2.2 Cooling method .....	22
2.3 Mounting and construction type .....	22
2.4 Delivery and storage .....	22
3 Installation .....	23
3.1 Preparing installation place .....	23
3.2 Installing .....	24
3.3 Electric connection .....	25
3.4 Checking after connection .....	27
4 Start-up .....	27
4.1 Checking before start-up .....	27
4.2 Test run .....	27
5 Operation and maintenance .....	28
5.1 Safety information during operation .....	28
5.2 Operation .....	29
5.3 Inspection and maintenance.....	30
5.4 Drive Application .....	32

# 1 Safety information

## 1.1 The five safety rules

For personal safety and to prevent damage, when carrying out any work, please always observe and obey safety instructions and the following five safety rules according to EN50110-1 "Working at voltage-free status". Apply the five safety rules in the sequence stated.

- ① Disconnect the system, including auxiliary circuits, for example, anti-condensation heaters.
- ② Make sure circuits not being re-connected coincidentally.
- ③ Verify no voltage on equipment.
- ④ Connect grounding and short-circuit.
- ⑤ Cover or isolate adjacent live parts.

Energize the system by recover the measures in reverse order.

## 1.2 Qualified personnel

All work on the machine must only be carried out by qualified personnel. For the purpose of this document, qualified personnel mean people who fulfill following requirements:

- Through appropriate training and experience, be able to recognize and avoid risks and potential dangers in responsibility.
- Must be appointed by responsible person.

## 1.3 Electromagnetic fields when operating electric machines

Electronic devices may be interfered by electric machines. Electromagnetic fields will be generated during electric machines' operating. Potentially lethal malfunctions can occur on medical implants, e.g. pacemakers, in the surrounding area of electric machines. Data may be lost in magnetic or digital data carriers.

- It is forbidden for people with pacemakers to stay nearby the machine.
- Take proper measures to protect personnel working in the plant. For example, making signs, safety barriers, setting safety instructions and markings.
- Obey safety and labor protection laws and regulations.
- Do not put magnetic and digital data media near electric machines.

This motor fulfills standard GB755 (IEC/EN60034-1). When used as prescribed, it complies with electromagnetic compatibility requirements.

## 1.4 Operating in hazardous area

Electric machines in hazardous area must be installed, commissioned, and operated only by qualified personnel, and must follow valid regulations.

---

### Note

Requirements of electric machines and operation in hazardous area can refer to standard GB 3836.15 (IEC/EN60079-14).

---

Users shall consult with local supervisor departments for evaluating area conditions and equipment risks, and to define necessary monitoring and control methods. These methods shall be organized as regulations and must be obeyed at any condition. Because of the variability of local conditions, motor manufacturer cannot provide universally applicable advices.

---

### Note

Assessment of electric machines and hazardous areas can refer to series standard GB/T3836 (IEC/EN60079).

---

For motors with third-party certifications, certified technical specifications and special conditions are fulfilled. Certification documents shall be observed.

For enclosure flameproof "db or d" Ex motors with marking "X" in certification number, repairing can only be taken according to manufacturers' instructions. Repairing according to standard values in GB/T3836.2 (IEC/EN60079-1) is not allowed.

## 2 Preparation before using

### 2.1 Application scope

1MT0003 series enclosure flameproof motor's designing and manufacturing fulfills standards GB/T3836.1 "Explosive atmospheres - Part 0: Equipment - General requirements" (IEC/EN60079-0) and GB/T3836.2 "Explosive atmospheres - Part 1: Equipment protection by flameproof enclosures "d" (IEC/EN60079-1). It is applicable to work in category II class B hazardous gas area. This series of motor fulfills energy level grade 3 of GB18613 "Minimum allowable values of energy efficiency and energy efficiency grades for small and medium three-phase asynchronous motors" (IE3 in IEC/EN60034-30). For energy efficiency of specific motor type, please refer to nameplate.

Motor's working condition is altitude within 1000m, ambient temperature -20°C-+40°C.

## 2.2 Cooling method

The standard cooling method is self-ventilation with fan according to IC411 in GB1993 (IEC/EN60034-6).

If use separately driven fan, cooling method code IC416, please design the circuit so as the motor cannot start-up when the separate fan is not running.

---

### Warning

#### Motor over-heating

Damage, serious injury, or death may occur if motor is over-heating.

- Do not block ventilation.
  - Prevent adjacent machines' expelled gas being sucked into motor's fan.
  - If motor installed vertically with fan upward, prevent objects and water fall into fan.
  - If motor installed vertically with drive end upward, prevent liquid flow on shaft.
- 

## 2.3 Mounting and construction type

Motor's mounting and construction type fulfills the standard GB/T997 "Rotating electrical machines - Classification of types of construction and mounting arrangements (IM Code)" (IEC/EN60034-7). It is stamped on motor's nameplate.

## 2.4 Delivery and storage

Check cargo's completeness immediately when receiving.

- Report any transportation damage to delivery agent immediately.
  - Report any defect/missing to Innomatics office immediately.
- 

### Note

#### Motor damage

Motor may be damaged if incorrectly stored.

Protection methods should be taken under critical climate conditions (e.g. salty/dusty, moisture environment).

---

Storage place should be horizontal, stable, and dry. Put the motor on pallet, wood block, or foundation to prevent moisture. Avoid sinking into ground. Covers or tarpaulins used to protect against weather must not contact machine's surface.

Avoid influence from critical climate. Storage place should be dry, well-ventilated, and avoid dust, frozen, impact, or severe vibration.

When store the motor for a long period ( $\geq 6$  month), anti-corrosion methods must be taken to bare metal surfaces.

---

### Warning

Explosion may occur if sealing material damaged

If motor is stored at exceeded temperature, sealing materials may be damaged due to temperature. Explosive gas and dust may leak into the motor and result to explosion. This may cause damage, serious injury, or death.

---

Conditions for storage:

Allowed ambient temperature: -20°C~+50°C

Allowed relative humidity: 60%

If the motor has special design for special ambient temperature, humidity, or altitude, its storage conditions may be different. In this case, please refer to the environment conditions on nameplate.

Period for storage:

Motor shaft shall be turned at least once a month to avoid brinelling. Long-term storage will shorten bearing grease lifetime.

For the motor with closed-type bearings, after two years storage, bearings should be replaces before using; for the motor with open-type bearings, after two years storage, new grease should be added before using. Bearing grease type, re-greasing quantity, and intervals can refer to nameplate.

## 3 Installation

### 3.1 Preparing installation place

The motor can be installed on the foundation of metal or concrete base. The foundation should have sufficient stiffness and strength to support the motor. General flatness for motor installation foundation:

Frame size	Flatness (mm)
≤132	0.10
160	0.15
≥180	0.20

The motor installation location should avoid exposing to long-time direct sunlight, rain, snow and ice.

For the motor installed vertically with drive end downward, should take protection measures to prevent objects falling into fan; for the motor installed vertically with drive end upward, should prevent liquid flowing along the shaft.

Ex motors must only be used in allowed environment.

When the installation bolt head interferes with the outer surface of the motor, please lift the motor away from the mating flange surface. First, the bolt through the flange installation hole, tighten the bolt to a position where the head does not interfere with the motor, connect the flange, and then tighten the installation bolt.

### 3.2 Installing

When assembling or dis-assembling transmission elements (like coupling, gear, or pulley), proper tools shall be used. Use heating assembly if necessary. Do not hit with hammers. The axial and radial loads applied on shaft extension must not exceed the maximum allowed values in catalogue.

Because of machining and assembly tolerances, there may be gap between motor feet and installation foundation. Please measure this gap, if it is over 0.05mm, please insert filling plates. The size of plates is determined according to the size of gap.

---

#### Warning

##### Motor falling

Damage, serious injury, or death may occur if motor falls.

- Check whether all eyebolts are tightened before lifting.
- Must use all eyebolts on the motor for lifting.
- Must use qualified hoisting tools and ropes for lifting.

---

If not specified, usually fasteners at least grade 8.8 according to GB/T3098.1 (ISO898-1) shall be used to fix and secure the motor.

The accuracy of alignment between motor and driven machine depends on the whole transmission system. The accuracy required by coupling manufacturer must be fulfilled. Motor's rotor is dynamically balanced. Only finished machined and balanced driven element is allowed to use. Must use proper tools to assemble and dis-assemble the transmission element. The driven element should be assembled by using the thread hole on shaft end or by hand in one time. Do not use hammer, otherwise bearings may be damaged.

---

#### Warning

##### Key throwing-out

Damage, serious injury, or death may occur if key thrown-out

- The key is only secured during transportation. If the motor start-up without transmission element, the key may be thrown out during rotating.
  - Please take measures to fix and secure the key on motor shaft if driven element is not assembled. Thus to prevent the key from throwing out.
-

Remark: The type of frequency converter used in the test of this product is SINAMICS G120 PM240-2. The similar frequency converter of this series should be used when the motor is used.

### 3.3 Electric connection

Danger

Dangerous voltage

Damage, serious injury, or death may occur.

- All connection can only be made by qualified professional personnel on static motor.
- Disconnect power source and make sure it cannot be re-connected coincidentally, including auxiliary circuits.
- Verify no voltage on the motor!
- Make reliable protection connection before working!
- Deviations between actual values and rated voltage, frequency, and phase can result to temperature rising. Meanwhile influent electromagnetic compatibility.
- Normally it is forbidden to operate non-grounded motor. Only in very rarely situations can be operated for very short time, for example when doing fault checking.

For the terminal box using hoop glands, the cable's diameter must matches with the hole diameter of the rubber sealing ring. Dimensions as following table.

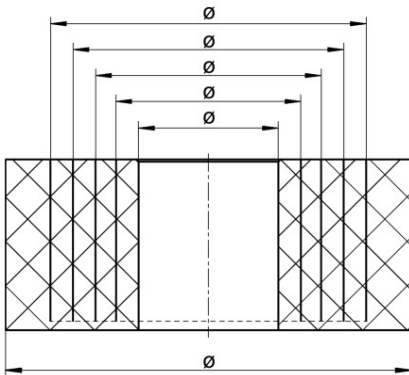

Frame size	Sealing ring hole diameter (mm)	Cable diameter (mm)
80~132	14	13
	20	19
	25	24
160~180	14	13
	20	19
	26	25
	31	30
	35	34
200~280	20	19
	26	25
	32	31
	38	37
	42	41
315~355	31	30
	36	35
	45	44
	50	49

For the terminal box with auxiliary cable entries, and the terminal box using glands, thread holes are provided on terminal box. The size and number of thread hole refer to catalogue. Standard motors are delivered with these thread holes sealed by qualified plugs. Only the gland, adapter, or plug with appropriate Ex certifications is allowed to use.

When connecting cables and terminals inside the terminal box, make sure the connection is tight and stable. Recommended tightening torque refers to following table.

Terminal bolt size		M4	M5	M6	M8	M10	M12	M16	M20
Torque (Nm)	min.	1	1.6	2.5	5	8	13	25	42
	max.	1.2	2	3	6	10	15.5	30	52

If the motor is equipped with accessories like temperature sensors or heaters, the connection of auxiliary circuits can refer to following terminal marking.

Motor winding temperature protection:

1 tri-wire PTC		2 tri-wire PTC		3 bi-wire single-lead PT100				6 bi-wire single-lead PT100															
15 <sup>th</sup> digit is B		15 <sup>th</sup> digit is C		15 <sup>th</sup> digit is H				15 <sup>th</sup> digit is J															
2TP1	2TP2	1TP1	1TP2	2TP1	2TP2	1R1	1R2	2R1	2R2	3R1	3R2	1R1	1R2	2R1	2R2	3R1	3R2	4R1	4R2	5R1	5R2	6R1	6R2
						3 tri-wire single-lead PT100																	
Option code Q35				Option code Q36				Option code Q63															
1R1		1R2		1R1		1R2		2R1		2R2		1R1		1R2		2R1		2R2		3R1		3R2	
6 tri-wire single-lead PT100																							
Option code Q64																							
1R1	1R1	1R2	2R1	2R1	2R2	2R2	3R1	3R1	3R2	3R2	4R1	4R1	4R2	4R2	5R1	5R1	5R2	5R2	6R1	6R1	6R2	6R2	

Motor bearing temperature protection:

2 bi-wire single-lead PT100				2 tri-wire single-lead PT100				2 tri-wire double-lead PT100													
Option code Q72				Option code Q78				Option code Q79													
10R1	10R2	11R1	11R2	10R2	10R1	10R2	11R1	11R1	11R2	10R1	10E1	11R1	11R1	11R2	10R2	12R1	12R1	13R1	13R1	13R2	12R2

The connection terminal for anti-condensation heater is 1HE1 and 1HE2. When delivered, the thread holes on terminal box are sealed with qualified plugs. After connection, unused holes shall remain sealed. Grounding points inside terminal box and on frame outside surface must be reliable grounded.

### 3.4 Checking after connection

Check following items after connection:

- Electric connection is completed according to previous instruction and tightened with proper torque.
- Electric clearance between non-insulated parts.
- No remaining wires.
- Connection is made so as the motor will rotate on correct direction.
- Keep terminal box inside clean, no foreign parts or objects remain.
- All sealing parts and joint surfaces must keep clean, and without damage.
- Unused cable entries must keep sealed.
- All grounding points are well connected.

## 4 Start-up

### 4.1 Checking before start-up

After installation and connection, check following items before commissioning:

- Motor is not damaged.
- Motor is installed and aligned as needed; driven elements are correctly balanced and assembled.
- All fasteners and connection parts are tightened.
- Motor's working conditions are allowed according to requirements, for example hazardous area category, IP protection level, ambient temperature.
- Moving parts, like couplings, can rotate freely.
- All active parts and live parts are protected.

### 4.2 Test run

Carry out a test run after installation:

- ① Start up the motor without load; check rotation direction.
- ② If motor runs normally, then connect load.

③ Check and record following data:

- Check noise and vibration during motor running.
- Record voltage, current, and power.
- Use available equipment to measure temperature in bearings and windings.

④ If motor runs unstably or makes abnormal noise, switch off immediately. And try to determine the problem during motor's slowing down:

- If noise or vibration obviously becomes better, the problem could be of electromagnetic issues.
- If noise or vibration does not change, the problem could be of mechanical issues. Possible causes include unbalance, misalignment, and resonance.

⑤ If the motor is equipped with separately driven fan, this separately fan rotation direction should be checked during test run.

## 5 Operation and maintenance

### 5.1 Safety information during operation

---

#### Danger

Dangerous voltage

Damage, serious injury, or death may occur

Electric machines have dangerous voltage, if contact machine surface, terminals, or other positions, dangers may occur.

---

#### Warning

Malfunctions during operation

Abnormal situation indicates that there may be malfunctions on the motor.

These may cause damage, serious injury, or death. Please take care of following situations:

- Higher power consumption than usual
  - Higher temperature than usual
  - Abnormal noise
  - Abnormal vibration
  - Abnormal smells
  - Response from monitoring devices
-

---

Note

Motor damage or short bearing lifetime

- Please absolutely maintain the permissible vibration, avoid unstable environment or impact. Thus to prevent bearings from damage.
  - Do not exceed the permissible axial and radial load values in catalogue.
  - When powered by converter, take measures to reduce bearing current.
- 

---

Note

Corrosion risks resulting from condensation

The changing of motor temperature or ambient temperature may cause condensation inside the motor. If the motor is equipped with anti-condensation heater, please make sure the heater is powered on when the motor is switched off.

---

---

Note

Motor over-heating

If the motor is equipped with anti-condensation heater, please make sure the heater is switched off before starting the motor.

---

If the motor is equipped with cylindrical roller bearings, during no-load operation the bearing easy to slip and the bearing noise is large. In the early stage of skidding, there may be obvious adhesion and trailing marks on the bearing raceway, so it is recommended to shorten the no-load running time or increase the radial preload force.

## 5.2 Operation

If possible, please start the motor without load and check noise. Use available equipment to check motor's temperature and vibration.

---

Note

Overload of motor direct-on-line

In addition to the load torque, motor's starting time is also influenced by moment inertial. When starting up, the current can be several times of rated current. This can result to over-heating and damage. So please take care of following items when starting up:

- Please comply with the limit values and conditions defined in catalogue and technical documents.
  - Monitor the ramp-up time every time to check whether abnormal issue happens.
- 

If the motor is equipped with separately driven fan, do not switch off this fan immediately when motor is powered off. Please wait for the motor to cool down. This can prevent the accumulation of residual heat.

For long-time stoppage (over 1 month), run the machine once a month, or at least turn the rotor. If the motor is stopped for over 12 month, please take proper measures of anti-corrosion, package, and drying; thus to prevent the motor from damage. Before starting again, please go through the checking and test run steps in Chapter 5.

### 5.3 Inspection and maintenance

---

#### Danger

Explosion hazards from static-electricity  
Damage, serious injury, or death may occur.

When cleaning, non-metal parts may generate static-electricity and ignite explosive substances. This may cause explosion.

- Do not execute cleaning in explosive atmosphere.
- Avoid static accumulation when cleaning non-metal parts.
- Do not use compressed air for cleaning.

---

After new motor's 500-hour-operation or 1-year-after-installation, please make the first time inspection:

- Whether rated electrical characteristics still remain.
- Whether bearings' temperature is still in permissible scope.
- Whether motor runs steady and smoothly.
- Whether there is crevice or deform of installation foundation.

According to the system, other items may also need to check.

After every 16000-hour-operation or 2-years-after-inspection, please make the following regular inspection:

- Whether rated electrical characteristics still remain.
- Whether bearings' temperature is still in permissible scope.
- Whether motor runs steady and smoothly.
- Whether there is crevice or deform of installation foundation.
- Whether alignment is still in valid tolerance.
- Whether all fasteners and connections are tightened.
- Whether all equipotential, grounding, and shield connections are connected and in contact.
- Whether the winding's insulation resistance is enough.
- Whether cables, sealings, and insulations are in good status, without discoloring.

When the motor undertakes the maximum allowed loads stated in catalogue, the guaranteed bearing life is at least 20000h. If the motor operates without load on shaft extension, the bearing life is at least 40000h. Please re-grease bearings according to the grease type, grease quantity, and intervals instructed on nameplate or technical documents. When adding grease, please rotate motor's rotor so new grease can distribute inside bearings.

Enclosure flameproof motors with marking "X" in certification can only be repaired according to manufacturer's instruction. It is forbidden to repair according to standard values in GB/T3836.2 (IEC/EN60079-1).

Information according to Article 33 of the REACH regulation

This product contains one or several subproducts in which the following substance – belonging to the "list of restrictions" – exists in a concentration exceeding 0.1 percent by weight.

- CAS No. 7439-92-1, lead

Based on currently available information, this substance does not represent any risk when correctly used, including its disposal.

## 5.4 Drive Application



In applications when motor torque is variable (piston-type compressor, load for example), the inevitable result is a non-sinusoidal motor current, whose harmonics can lead to excessive system perturbation or excessive electromagnetic interference.

### Electromagnetic compatibility

In application where the motor is driven by a drive, the degree of electrical interference depends on the type of used drive (type, number of IGBTs, interference suppression measures, and manufacturer), cabling, distance and application requirements.

The installation guidelines of the drive manufacturer with regards to electromagnetic compatibility must be considered at all times during the design and implementation phases.



If the motor is driven by a drive and the operating speed exceeds synchronous speed then considerations must be given to the mechanical components and transmission coupling.

Please refer to IEC 60034-1 for further details.

### Noise, Temperature and Vibration

When motor are used with converter fed operation, the noise and temperature rise will be a little worse than standard motor with rated speed.

Due to increased speeds above the rated speed, vibration of motor will increase. Therefore the mechanical smooth running is changed, and lifetime of grease and bearing will be reduced. Motor frequency and torque as following table.

Frame Size	IC411		IC416	
	Frequency(Hz)	Torque (Nm)	Frequency(Hz)	Torque (Nm)
0D	3-100	1.5~5.5	3-85	2.5~6.0
0E	3-100	3.0~11	3-85	5.0~12
1A	3-100	6.0~19	3-85	10~20
1B	3-100	8.0~25	3-80	13~27
1C	3-100	10~50	3-70	15~55
1D	3-100	20~100	3-70	35~110
1E	3-100	40~140	3-70	70~150
2A	3-100	55~200	3-70	95~215
2B	3-85	95~270	3-70	145~295
2C	3-80	115~360	3-70	175~390
2D	3-75	155~540	3-70	240~585
3A	3-65	230~1320	3-65	350~1420
3B	3-65	460~2385	3-60	700~2580

## FS315~355 Insulated bearinggs when operated with a converter

If the machine is operated from a low-voltage converter, insulated bearings are fitted at the NDE and an insulated encoder with insulated bearings(option).

Comply with the plates on the machine relating to bearing insulation and possible bridges.

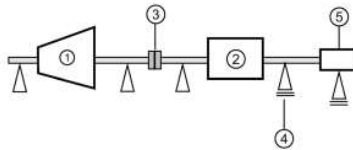

- |                                |                      |
|--------------------------------|----------------------|
| ① Driving machine              | ② Motor              |
| ③ Coupling                     | ④ Insulated bearings |
| ⑤ Insulated tachometer fitting |                      |

Schematic representation of a single drive

---

Notice !

### Bearing damage

The bearing insulation must not be bridged. Bearing currents can damage bearings.

- Do not bridge the bearing insulation for subsequent installation work, such as the installation of an automatic lubrication system or a non-insulated vibration sensor.
- Please contact the service center if necessary.

---

### Reducing bearing currents

A thorough and careful evaluation of the overall system of motors, frequency converters and load machines is necessary to ensure that damage caused by bearing currents can be avoided.

- In addition to grounding the motor through a solid protected ground cable, flat copper core braided cable or high frequency stranded cable should be used for low impedance grounding in the high frequency range. These cables need to be connected through a large contact area. Due to skin effect, solid copper cable is not suitable for high-frequency grounding.
- The motor wiring is connected to the converter using a symmetrical shielded cable. The braided shielding layer composed of many thin wires must have good electrical conductivity. A shielding net made of copper or aluminum wire is more suitable. The cable shield layer should be connected at both ends of the motor and frequency converter, and the unshielded cable head should be as short as possible.

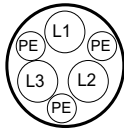
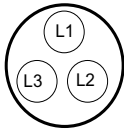

Concentric copper or aluminum

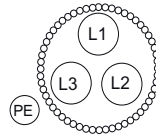

shield Steel armor

- Keep the area of the plane contact surface at both ends of the shielded cable large to ensure better discharge of high-frequency current. The cable shield layer should be 360° bonded to the motor housing and the protective ground busbar of the converter, if any:
    - Motor side: EMC grounds at the cable entries
    - Converter side: EMC shield ring
  - In the overall system, set up a properly meshed grounding system with low impedance for high frequency currents.
  - There is no potential difference among motor, converter and driven machine.
    - Use equipotential bonding conductors between the terminal box and the RF grounding point at the motor enclosure.
    - Use separate high-frequency equipotential bonding conductors between the motor enclosure and protective ground busbar of the converter.
    - Use separate high-frequency equipotential bonding conductors between the motor enclosure and the driven machine.
  - Use the common-mode filter (magnet ring) at the converter output. The Innomatics sales representative is responsible for selection and dimensioning.
  - Limit the rise in voltage by using output filters. Output filters dampen the harmonic content in the output voltage.
  - Install electric reactor for motor.
- The operating instructions for the converter are not part of this documentation. Refer to the configuration information for the converter.



## 5.5 Flameproof dimension drawing

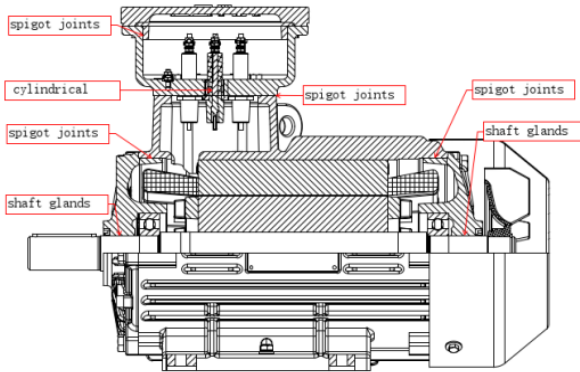

FS80-132

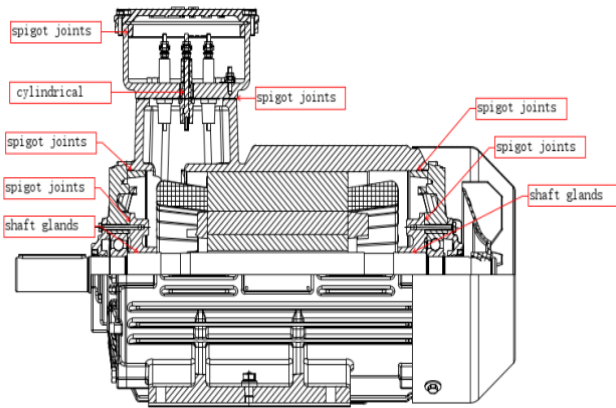

FS160-355

Remarks: If the flameproof joint surface is damaged, it is not allowed to repair, and the parts must be replaced.



贝得电机的服务范围仅限中国大陆地区  
The service area of Beide motor is in China mainland

本公司产品服务由当前服务商或售后服务部负责  
Product service is provided by current service agent or post-sale  
department



售后支持  
After-sales support

订货号：103063078  
如有变动，恕不事先通知

本手册中提供的信息只是对产品的一般说明和特性介绍。文中内容可能与实际应用的情况有所出入，并且可能会随着产品的进一步开发而发生变化。仅当相关合同条款中有明确规定时，茵梦达方有责任提供文中所述的产品特性。

手册中涉及的所有名称可能是茵梦达公司或其供应商的商标或产品名称，如果第三方擅自使用可能会侵犯所有者的权利。