

1MT8004/1MT8005 系列隔爆型三相异步电动机
1MT8004/1MT8005 Series Gas Explosion-proof
Three-phase Asynchronous Motor

使用维护说明书
INSTRUCTIONS

茵梦达（中国）有限公司
Innomotics Standard Motors Ltd.

2026.05

目录

1 安全信息.....	3
1.1 五条安全原则	3
1.2 合格人员	3
1.3 使用电气设备时的电磁场.....	3
1.4 在危险区域使用	4
2 使用前的准备.....	5
2.1 应用范围.....	5
2.2 冷却方式	6
2.3 安装结构形式	7
2.4 运输和保存	7
2.5 型号命名解释及规格代码说明	8
3 安装.....	9
3.1 准备安装区域	9
3.2 确保合理的冷却	9
3.3 安装	10
3.4 电气连接	11
3.5 连接后的检查	15
4 启动.....	16
4.1 启动前的检查	16
4.2 试运行	16
5 运行和维护.....	17
5.1 运行中的安全提示	17
5.2 运行	18
5.3 检查和维护	19
5.4 隔爆结构示意图	21
English version.....	22

1 安全信息

1.1 五条安全原则

开展作业时，为保障人身安全和避免财产损失，请始终遵守安全注意事项和下面符合 EN50110-1“在无电压状态下工作”的五项安全规程。开始作业前请按照以下顺序实施五项安全规程。

- (1) 断电，包括断开辅助电路，例如防潮加热带等。
- (2) 确保不会意外通电。
- (3) 确认设备上已无电压。
- (4) 接地并短接。
- (5) 遮盖或隔离邻近的带电部件。

结束作业后按照相反的顺序取消上述措施。

1.2 合格人员

只允许由专业人员调试和操作设备。本文中涉及的专业人员必须满足以下前提条件：

- 必须接受过相关培训且具备相应经验，能够发现职责范围内的风险，避免发生危险。
- 必须是由负责人委任的相应人员进行作业。

1.3 使用电气设备时的电磁场

电气设备可干扰电子设备。电气设备在运行中会产生电磁场。在电机附近逗留可能会使医疗植入体，如心脏起搏器等，出现危及生命的故障。磁性或电子数据存储设备可能会发生数据丢失。

- 禁止佩戴心脏起搏器的人员在电机附近逗留。
- 采取适当措施，如设置标识、封锁工作区域、张贴安全须知和警示标志等，为在设备周围工作的人员提供充分的保护和提醒，防止其受到伤害。
- 请遵守所在地区的安全和劳保保护规定。
- 请不要让磁性或电子数据存储设备靠近电机。

本电机符合 GB/T 755（IEC/EN60034-1）标准，在按照规定使用时满足关于电磁兼容性的要求。

1.4 在危险区域使用

在爆炸性环境中使用的电气设备必须由合格人员按照现行有效的规定进行安装、调试和操作。

说明

关于爆炸性环境中的电气设备及其运行的基本要求可查阅标准 GB 3836.15 (IEC/EN60079-14)。

设备使用者应咨询当地主管部门，评估现场环境条件和设备操作风险，以确定必要的监控措施，并将这些措施制定为规定。在任何条件下都必须遵守这些规定。由于现场条件各有不同，电机制造商无法提供普遍适用的建议。

说明

关于电气设备及爆炸性环境的评估方法，可查阅系列标准 GB/T3836 (IEC/EN60079)。

如果电机获得了第三方认证，则表明电机符合其中所规定的技术数据和特殊条件，应在调试前查看证书。

使用防爆认证带“X”标记的防爆电机时，对于隔爆型“db 或 d”电机，只能在遵守制造商设计说明的情况下才能维修该产品。不允许按照 GB/T3836.2 (IEC/EN60079-1) 中的标准值进行维修。

2 使用前的准备

2.1 应用范围

1MT8004/1MT8005 系列隔爆型三相异步电动机的设计和制造符合标准 GB/T3836.1《爆炸性环境—第 1 部分：设备通用要求》（IEC/EN60079-0）和 GB/T3836.2《爆炸性环境—第 2 部分：由隔爆外壳“d”保护的的设备》（IEC/EN60079-1）。适用于 II 类 B 级爆炸性气体存在的工作环境。

1MT8004/1MT8005 系列电机符合 GB18613《中小型三相异步电动机能效限定值及能效等级》中规定，其中：

1MT8004 满足 2 级能效要求；

1MT8005 满足 1 级能效要求。

具体规格电机的能耗指标参见电机上的铭牌。

电机工作环境条件为海拔不超过 1000 米，环境温度范围-20°C~+40°C。D03 选项时环境温度范围-40°C~+40°C，N05、N06、N07和N08选项时环境温度范围-20°C~+60°C。防爆标志为 Ex db IIB T4 Gb。当产品使用外购的电缆引入装置时，其应与整机使用环境相适应且取得防爆认证。

涉及电压频率：

220V/380V 50Hz、230V/400V 50Hz、240V/415V 50Hz、380V/660V 50Hz、400V/690V 50Hz、220V 50Hz、230V 50Hz、240V 50Hz、380V 50Hz、400V 50Hz、415V 50Hz、440V 50Hz、460V 50Hz、480V 50Hz、500V 50Hz、575V 50Hz、660V 50Hz、690V 50Hz、220V/380V 60Hz、230V/400V 60Hz、240V/415V 60Hz、380V/660V 60Hz、400V/690V 60Hz、220V 60Hz、230V 60Hz、240V 60Hz、380V 60Hz、400V 60Hz、415V 60Hz、440V 60Hz、460V 60Hz、480V 60Hz、500V 60Hz、575V 60Hz、660V 60Hz、690V 60Hz。

该产品外壳防护等级：IP55/IP56/IP65/IP66。

电机型谱：

1MT8004-0DA2、1MT8004-0DA3、1MT8004-0DB2、1MT8004-0DB3、
1MT8004-0DC3、1MT8004-0EA0、1MT8004-0EA4、1MT8004-0EB0、
1MT8004-0EB4、1MT8004-0EC0、1MT8004-0EC4、1MT8004-1AA4、
1MT8004-1AB4、1MT8004-1AB5、1MT8004-1AC4、1MT8004-1BA2、
1MT8004-1BB2、1MT8004-1BC2、1MT8004-1CA0、1MT8004-1CA1、
1MT8004-1CB0、1MT8004-1CB2、1MT8004-1CC0、1MT8004-1CC2、
1MT8004-1CC3、1MT8004-1CD0、1MT8004-1CD2、1MT8004-1DA2、
1MT8004-1DA3、1MT8004-1DA4、1MT8004-1DB2、1MT8004-1DB4、
1MT8004-1DC2、1MT8004-1DC4、1MT8004-1DD2、1MT8004-1DD3、
1MT8004-1DD4、1MT8004-1EA2、1MT8004-1EB2、1MT8004-1EB4、
1MT8004-1EC4、1MT8004-1ED4、1MT8004-2AA4、1MT8004-2AA5、
1MT8004-2AB5、1MT8004-2AC4、1MT8004-2AC5、1MT8004-2AD5、
1MT8004-2BA2、1MT8004-2BB0、1MT8004-2BB2、1MT8004-2BC2、
1MT8004-2BD0、1MT8004-2BD2、1MT8004-2CA2、1MT8004-2CB2、
1MT8004-2CC2、1MT8004-2CD2、1MT8004-2DA0、1MT8004-2DA2、
1MT8004-2DB0、1MT8004-2DB2、1MT8004-2DC0、1MT8004-2DC2、
1MT8004-2DD0、1MT8004-2DD2、1MT8004-3AA0、1MT8004-3AA2、

1MT8004-2DB0、 1MT8004-2DB2、 1MT8004-2DC0、 1MT8004-2DC2、
1MT8004-2DD0、 1MT8004-2DD2、 1MT8004-3AA0、 1MT8004-3AA2、
1MT8004-3AA5、 1MT8004-3AA6、 1MT8004-3AA7、 1MT8004-3AB0、
1MT8004-3AB2、 1MT8004-3AB5、 1MT8004-3AB6、 1MT8004-3AB7、
1MT8004-3AC0、 1MT8004-3AC2、 1MT8004-3AC5、 1MT8004-3AC6、
1MT8004-3AD0、 1MT8004-3AD2、 1MT8004-3AD5、 1MT8004-3BA2、
1MT8004-3BA3、 1MT8004-3BA5、 1MT8004-3BA6、 1MT8004-3BB2、
1MT8004-3BB3、 1MT8004-3BB5、 1MT8004-3BB6、 1MT8004-3BC2、
1MT8004-3BC3、 1MT8004-3BC4、 1MT8004-3BC5、 1MT8004-3BC6、
1MT8004-3BD2、 1MT8004-3BD3 1MT8004-3BD5、 1MT8004-3BD6

1MT8005-0DA2、 1MT8005-0DA3、 1MT8005-0DB2、 1MT8005-0DB3、
1MT8005-0DC3、 1MT8005-0EA0、 1MT8005-0EA4、 1MT8005-0EB0、
1MT8005-0EB4、 1MT8005-0EC0、 1MT8005-0EC4、 1MT8005-1AA4、
1MT8005-1AB4、 1MT8005-1AB5、 1MT8005-1AC4、 1MT8005-1BA2、
1MT8005-1BB2、 1MT8005-1BC2、 1MT8005-1CA0、 1MT8005-1CA1、
1MT8005-1CB0、 1MT8005-1CB2、 1MT8005-1CC0、 1MT8005-1CC2、
1MT8005-1CC3、 1MT8005-1CD0、 1MT8005-1CD2、 1MT8005-1DA2、
1MT8005-1DA3、 1MT8005-1DA4、 1MT8005-1DB2、 1MT8005-1DB4、
1MT8005-1DC2、 1MT8005-1DC4、 1MT8005-1DD2、 1MT8005-1DD3、
1MT8005-1DD4、 1MT8005-1EA2、 1MT8005-1EB2、 1MT8005-1EB4、
1MT8005-1EC4、 1MT8005-1ED4、 1MT8005-2AA4、 1MT8005-2AA5、
1MT8005-2AB5、 1MT8005-2AC4、 1MT8005-2AC5、 1MT8005-2AD5、
1MT8005-2BA2、 1MT8005-2BB0、 1MT8005-2BB2、 1MT8005-2BC2、
1MT8005-2BD0、 1MT8005-2BD2、 1MT8005-2CA2、 1MT8005-2CB2、
1MT8005-2CC2、 1MT8005-2CD2、 1MT8005-2DA0、 1MT8005-2DA2、
1MT8005-2DB0、 1MT8005-2DB2、 1MT8005-2DC0、 1MT8005-2DC2、
1MT8005-2DD0、 1MT8005-2DD2、 1MT8005-3AA0、 1MT8005-3AA2、
1MT8005-3AA5、 1MT8005-3AA6、 1MT8005-3AA7、 1MT8005-3AB0、
1MT8005-3AB2、 1MT8005-3AB5、 1MT8005-3AB6、 1MT8005-3AB7、
1MT8005-3AC0、 1MT8005-3AC2、 1MT8005-3AC5、 1MT8005-3AC6、
1MT8005-3AD0、 1MT8005-3AD2、 1MT8005-3AD5、 1MT8005-3BA2、
1MT8005-3BA3、 1MT8005-3BA5、 1MT8005-3BA6、 1MT8005-3BB2、
1MT8005-3BB3、 1MT8005-3BB5、 1MT8005-3BB6、 1MT8005-3BC2、
1MT8005-3BC3、 1MT8005-3BC4、 1MT8005-3BC5、 1MT8005-3BC6、
1MT8005-3BD2、 1MT8005-3BD3 1MT8005-3BD5、 1MT8005-3BD6

2.2 冷却方式

电机标配冷却方式为自扇冷式，符合 GB1993 中的 IC411 冷却方式（IEC/EN60034-6）。

警告

电机过热

如果不注意以下几点，可能会造成财产损失、重伤或死亡。

- 切勿阻碍通风。
 - 防止临近机组的废气被电机风扇直接吸入。
 - 对于进风口朝上的竖直安装的电机，应防止异物和水从进风口进入。
 - 对于轴端朝上的竖直安装的电机，应防止液体沿轴端流入电机。
-

2.3 安装结构形式

电机的安装结构形式符合 GB/T997《旋转电机结构型式、安装型式及接线盒位置的分类（IM 代码）》（IEC/EN60034-7）。电机铭牌上表示出了其安装结构形式。

2.4 运输和保存

收货后立即检查货物是否与随附单证相一致。

- 立即向运输代理商报告任何明显的运输损坏。
- 如有明显缺失/不完整，应立即通知相应的茵梦达办事处。

注意

电机损坏

未按规定存放可能会损坏电机。

在极端气候条件下（如含盐和/或积尘、潮湿的环境），应采取适当的防护措施。

选择水平、稳固且干燥的存放位置。将电机、设备和包装箱放置在底架、大方木料或基座上，以防止地面湿气。防止电机陷入地下。防潮用的盖布或防雨布不得与所存放物品的表面接触。

应防止受极端天气的影响。存放位置应保持干燥、通风良好并且防尘、防冻、防撞、防止剧烈振动。

长期存放时（≥6个月），须对裸露的金属表面采取适当的防腐措施。

警告

密封材料损坏可能引发爆炸在超出允许的环境温度下存放电机，可能导致密封材料因温度而损坏，导致密封失效。这可能让爆炸性气体和粉尘等异物进入电机，从而引发爆炸。这可能造成财产损失、重伤或死亡。

存放电机的环境条件：

允许的温度范围：-20°C~+50°C

允许的最大空气湿度：60%对于环境温度、湿度或海拔有特殊要求的电机，其存放条件需遵守其它要求。此时请参考电机铭牌上对于环境条件的说明。

存放时间：

每半年必须至少旋转电机轴 1 次，以避免侵蚀。长期存放会降低轴承润滑脂的使用寿命

使用寿命。对于密封型轴承，在存放超过两年后，电机使用前应更换前后轴承；对于配备了再润滑装置的电机，在存放超过两年后，应向前后轴承注入新的润滑脂。可再润滑型轴承的润滑脂型号、加注油脂量和再润滑周期见电机铭牌。

2.5 型号命名解释及规格代码说明

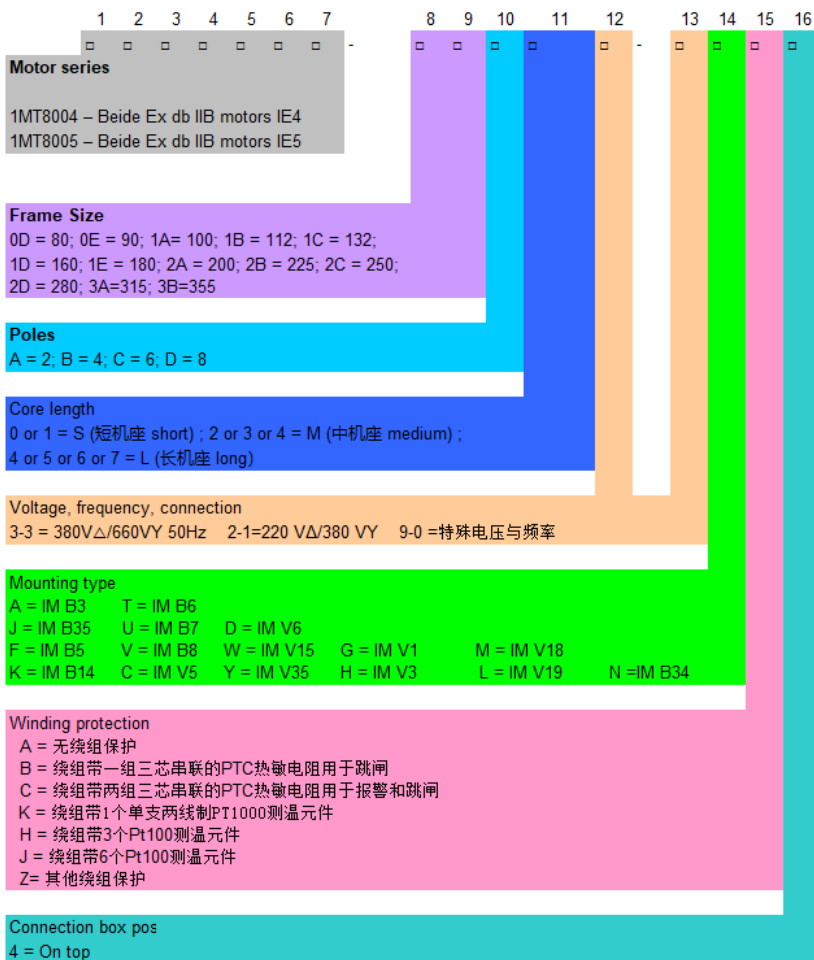

3 安装

3.1 准备安装区域

电机安装的基础可以是金属底座，也可以是混凝土平台。基础应具有足够的强度与刚度来支撑电机。常用电机支承面的平面度要求如下：

安装位置应避免长时间受强烈阳光直接照射、雨雪、冰雹的侵蚀。

机座号	平面度 (mm)
≤132	0.10
160	0.15
≥180	0.20

对于轴伸向下竖直安装的电机，应避免异物落入风扇罩。对于轴伸向上竖直安装的电机，应避免液体沿轴伸流入电机。

防爆电机只能在允许的环境中使用。

3.2 确保合理的冷却

警告

电机过热

如果不注意以下几点，可能会造成财产损失、重伤或死亡。

- 切勿阻碍通风。
- 防止临近机组的废气被直接吸入。
- 对于风扇进气口朝上的竖直安装的电机，应防止异物和水从进气口进入。
- 对于轴伸端朝上的竖直安装的电机，应防止液体沿轴流入电机。

对于带有独立驱动风扇的电机，请对电路进行设计以防止在独立风扇未运行时接通电源并运行主电机。

电机安装时风路的考虑见下表。

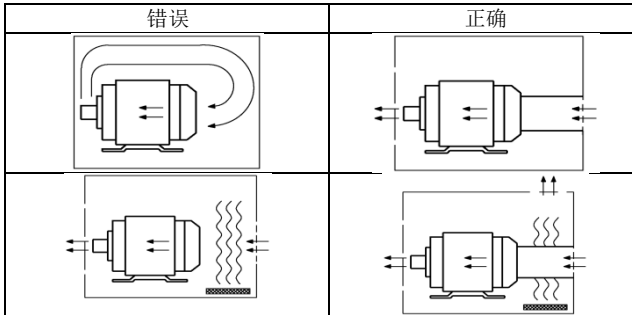

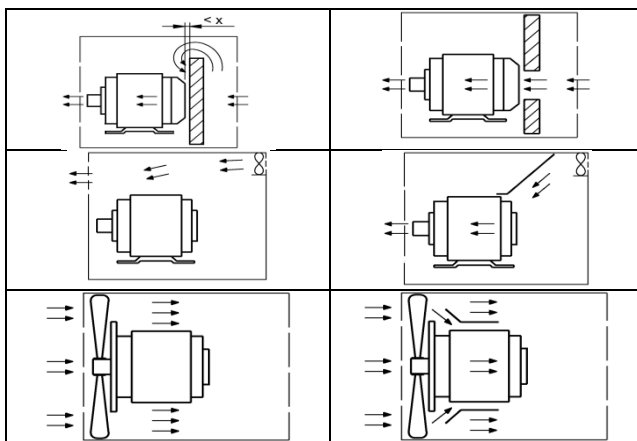

电机进风口与相邻模块的最小间距“X”尺寸见下表

机座号	X (mm)
80...100	20
112	25
132	30
160	40
180...200	90
225...250	100
280...315	110
355	140

3.3 安装

对轴上传动件（联轴器、齿轮、皮带轮等）进行拆装时，应使用合适的工具，必要时进行热套操作。请勿使用锤子或类似工具敲击。电机轴伸上允许施加的径向载荷和轴向载荷不得超过样本上规定的最大值。

由于机械部件制造公差及累积误差的存在，电机底脚平面与安装基础的接触面之间可能存在间隙。安装时应用塞尺测量此间隙，对于 $\geq 0.05\text{mm}$ 的间隙，应插入合适的填隙片。填隙片尺寸根据实际间隙大小配做。

当安装螺栓头部与电机外圆面发生干涉时，请将电机吊离对接法兰盘面，先将螺栓穿过法兰安装孔，把螺栓拧至头部与电机不干涉，对接法兰盘，再拧紧安装螺栓。

警告

电机掉落

如果不注意以下几点，可能会造成财产损失、重伤或死亡。

- 起吊前确保吊环都已拧紧。
- 起吊时必须使用电机上所有吊环。

- 务必使用合格的吊装索具进行作业。

除非另行规定，通常需使用符合 GB/T3098.1（ISO898-1）中规定的强度等级至少为 8.8 的紧固件，以安全固定电机。电机与被驱动设备间所需对中精度主要取决于整个电机传动系统的配置。对时务必须遵循联轴器制造商要求的对中精度。电机转子是动平衡的。只能使用已钻好孔并校准过平衡的从动元件。只能使用合适的工具安装和拆卸从动元件。使用轴顶端的螺纹孔或用手推将从动元件一次性装入。不允许使用锤子敲打，否则会损坏轴承。

警告

键可能抛出

如果不注意以下几点，可能会造成财产损失、重伤或死亡。

- 键仅在运输过程中被固定以防止脱落，如果电机在未安装从动元件时启动，则键可能会在运行期间被抛出。
 - 请固定好无从动元件的轴伸上的键，防止键被抛出。
-

注：本产品试验时配有变频器型号为 SINAMICSG120PM240-2，电机使用时应选用该系列或相似的变频器。

3.4 电气连接

危险

危险电压

可能导致死亡、重伤或财产损失。

- 所有操作只能由合格的专业人员在静止的电机上进行
 - 断开电源并确保不会被意外接通，该要求同样针对辅助电路
 - 确认无电压！
 - 在开始工作前进行可靠的保护线连接！
 - 供电电网的电压、频率、波形等相对于额定值的偏差会导致温度升高，同时也会影响电磁兼容性。
 - 通常情况下不允许运行未接地的电机。只在极少数情况下可短暂运行，例如排查故障时。
-

对于使用喇叭口型进线斗的接线盒，选择电缆时，电缆直径需与进线斗内橡胶密封圈孔径相匹配，尺寸见下表。对于N05、N06、N07、N08 使用环境温度高于40℃不超过60℃时选用耐温不低于98℃ 的电缆。

警告

客户在打开接线盒盖接线时，切勿进行敲击或撬动，防止损伤隔爆面。应使用较长螺钉均匀地压入设置在接线盒盖上的两个螺纹孔，辅助接线盒盖的拆卸。接线完毕后，关闭接线盒盖时，应将此处的两只短螺钉复原、拧紧，防止影响防护等级。

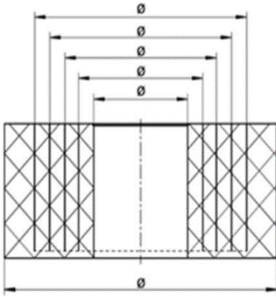

机座号	密封圈孔径 (mm)	电缆外径 (mm)
80~132	14	13
	20	19
	25	24
160~180	14	13
	20	19
	26	25
	31	30
200~280	35	34
	20	19
	26	25
	32	31
	38	37
315~355	42	41
	31	30
	36	35
	45	44
	50	49
	60	59
	70	69

对于带辅助进线孔的接线盒，以及使用葛兰作为主电缆进线装置的接线盒，在接线盒上有用于安装葛兰的螺纹孔，螺纹孔尺寸和数量参考样本，电机出厂时这些螺纹孔由符合要求的闷盖密封，必须使用具有相应防爆区域（Zone 分区）和防爆等级认证的并带有相应标识的葛兰、转接头和堵头。

在接线盒内进行接线时，需确保电缆与接线螺栓连接可靠，接线螺栓推荐的拧紧力矩参考下表。

接线螺栓规格		M4	M5	M6	M8	M10	M12	M16
拧紧力矩 (Nm)	最小	1	1.6	2.5	5	8	13	25
	最大	1.2	2	3	6	10	15.5	30

关于电机机壳外接地螺栓和接线盒内接地螺栓规格，请参考下表。

机座号	80-90	100-132	160	180	200-225	250-280	315-355
机壳外部接地螺栓规格	M6	M8	M8	M12	M12	M12	M12
接线盒内接地螺栓规格	M5	M5	M6	M6	M8	M10	M12

若电机选配了温度传感器、防潮加热带等选项，其辅助电路的连接参考下面接线端子标识的说明。

电机绕组温度保护：

一组三芯 串联的 PTC	第 15 位为 B	2TP1
		2TP2
两组三芯 串联的 PTC	第 15 位为 C	1TP1
		1TP2
		2TP1
		2TP2
三个单支 两线制 PT100	第 15 位为 H	1R1
		1R2
		2R1
		2R2
		3R1
		3R2
六个单支 两线制 PT100	第 15 位数为 J	1R1
		1R2
		2R1
		2R2
		3R1
		3R2
		4R1
		4R2
		5R1
		5R2
		6R1
		6R2
一个单支 两线制 PT1000	选项代码Q35	1R1
		1R2
两个单支 两线制 PT100	选项代码Q36	1R1
		1R2
		2R1
		2R2
三个单支 三线制 PT100	选项代码为Q63	1R1
		1R1
		1R2
		2R1
		2R1
		2R2

		3R1
		3R1
		3R2
六个单支 三线制 PT100	选项代码Q64	1R1
		1R1
		1R2
		2R1
		2R1
		2R2
		3R1
		3R1
		3R2
		4R1
		4R1
		4R2
		5R1
		5R1
		5R2
		6R1
6R1		
		6R2

电机轴承温度保护：

两个单支 两线制 PT100	选项代码Q72	10R1
		10R2
		11R1
		11R2
两个单支 三线制 PT100	选项代码Q78	10R1
		10R1
		10R2
		11R1
		11R1
两个双支 三线制 PT100	选项代码Q79	11R2
		10R1
		10R1
		10R2
		11R1
		11R1
		11R2
		12R1
		12R1
		12R2
13R1		
13R1		
		13R2

防潮加热带的接线端子编号为 1HE1 和 1HE2。

注：

- 1.电机绕组温度保护，PTC、PT100&PT1000，建议报警温度设定为 145°C，跳闸温度设定为 155°C；
 - 2.电机轴承温度保护，PT100，建议报警温度设定为 95°C，跳闸温度设定为 105°C。
 - 3.为保证电缆和密封圈运行可靠，需根据电机额定电流选择合适的电缆，确保电缆引入装置入口和电缆分支点最高工作温度分别不超过 70°C 和 80°C。高于该温度时应考虑更换电缆，并与制造单位联系确认适用性。
- 电机出厂时接线盒上的进线孔已使用符合要求的闷盖密封，接线后未使用的进线孔应保持其密封状态。接线盒内的接地和机壳外部的接地点必须有效接地。
- 建议用户按照 GB 3836.15 要求设置与电机相匹配的电气保护。

3.5 连接后的检查

在完成接线后应检查以下几点：

- 接线盒中的电气连接已按照前面的说明完成，并以正确的力矩拧紧。
- 非绝缘组件之间的电气间隙。
- 不能有遗留的线头。
- 电机按照需要的旋转方向进行接线。
- 接线盒内必须保持整洁，不能有多余的零件和杂物。
- 所有密封件和接合面不能有损伤，且须保持干净。
- 接线盒中未使用的进线孔密封完好。
- 所有接地点都已正确接地。

4 启动

4.1 启动前的检查

在完成安装和连接后，在调试前请检查以下事项：

- 电机未受损。
- 电机按要求进行了安装和对中，被驱动组件已进行了正确的平衡和设置。
- 所有紧固件和电气连接件都已拧紧。
- 电机运行条件与技术文档中的规定一致，如爆炸环境类别、防护等级、环境温度等。
- 可移动部件，如联轴器等，可自由转动。
- 所有活动件和带电零件都进行了安全防护。

4.2 试运行

在安装电机后执行一次试运行：

- (1) 首先空载启动电机，检查电机旋转方向。
- (2) 空载正常时，给电机连接负载。
- (3) 在试运行期间检查并记录以下数据：
 - 检查运转时的噪声和振动情况。
 - 记录电压、电流和功率值。
 - 尽量使用可用的测量设备，检查轴承和绕组的温度。
- (4) 如果电机运行不平稳或发出异响，应立即关闭电机，并在电机惯性停转过程中排查故障原因：
 - 如果断开电源后噪声或振动明显改善，则说明是电磁方面的原因。
 - 如果断开电源后没有改善，则说明是机械方面的原因。可能的原因包括电机或负载设备不平衡，机组未充分对中，电机和系统发生共振。
- (5) 如果电机使用独立驱动风扇，则应在试运行时检查独立风扇的转向。

5 运行和维护

5.1 运行中的安全提示

危险

危险电压

可能导致死亡、重伤或财产损失。电气设备带有危险电压，如果接触设备表面、端子等部位，可能存在触电危险。

警告

运行期间的故障 运行过程中的异常状况表示电机可能出现了故障。这些故障可能导致财产损失、重伤或死亡。请注意以下故障征兆：

- 异常高功率消耗
 - 异常高温
 - 异常噪声
 - 异常振动
 - 异常气味
 - 监控装置发出的响应
-

注意

电机损坏或轴承寿命缩短

- 务必要遵守允许的振动值，避免不平稳的工作环境和冲击，以避免电机或轴承损坏。
 - 务必要遵守样本上允许的轴向径向载荷。
 - 使用变频器驱动时，采取措施减小轴承电流。
-

注意

冷凝水引起的腐蚀危险 电机温度或环境温度的变化可能造成电机内部出现冷凝水。如果电机带有防潮加热带，请确保在关闭电机后，防潮加热带被接通。

注意

电机过热

如果电机带有防潮加热带，请确保在启动电机前，防潮加热带停止工作。

若电机装配圆柱滚子轴承，空载运行时因无径向预紧力，轴承易发生打滑，轴承噪声大。打滑初期，会在轴承滚道及滚动体上产生明显的粘着与拖尾痕迹，建议缩短空载运行时间或增加一定的径向预紧力。

5.2 运行

请尽可能在空载时启动电机并检查运转噪声。使用可用的测量设备，检查电机运行时的温度和振动。

注意

直连运行的电机出现过载 除了反作用力矩，启动时间还主要受转动惯量的影响。启动时，电机的电流会达到额定电流的数倍。这会导致电机过热，电机可能被损坏。因此启动时应注意以下几点：

- 请遵循产品样本或订货文档中涉及的极限值或启动条件。
 - 监控每次启动时间以检查是否出现异常。
-

若电机长时间停机（超过 1 个月），应每月运行一次，或至少转动转子一次。若电机停机时间超过 12 个月，请采取适当的防腐蚀、包装及干燥措施，否则电机可能因环境影响而损坏。并在再次开机前执行第 5 章中的检查和运行。

5.3 检查和维护

危险

静电可引发爆炸

可能导致死亡、重伤或财产损失。

清洁时，塑料部件可能产生静电并引燃爆炸性介质，这可能会导致爆炸。

- 确保不在爆炸性环境中进行清洁。
 - 清洁非金属部件时，避免静电积聚。
 - 请勿使用压缩空气进行清洁。
-

警告

严禁带电开盖，所有工作必须有熟练的工人进行操作，电机做任何操作工作之前，确保电机与主线及辅助电源断开。并且确保电源不被意外开启。

在新电机运行约 500 小时或最晚一年后，请进行首次检查：

- 电机是否保持规定的电气特性。
- 轴承温度是否在允许范围内。
- 电机是否运行平稳，没有发出更大噪声。
- 电机安装基座是否出现裂缝和凹陷。根据系统本身的特殊条件，可能还要完成其它的检查项目。

建议在电机运行 16000 小时或最晚两年后，进行例行检查：

- 电机是否保持规定的电气特性。
- 轴承温度是否在允许范围内。
- 电机是否运行平稳，没有发出更大噪声。
- 电机安装基座是否出现裂缝和凹陷。
- 电机的对中是否在允许的公差范围内。
- 所有机械和电气连接的紧固件都保持拧紧状态。
- 所有等电位连接、接地连接和屏蔽层的位置都正确并正常接触。
- 绕组的绝缘电阻足够大。
- 电缆、密封件、绝缘件的情况良好且没有变色现象。电机按照样本上所规定的最大载荷值运转时，轴承寿命至少为 20000 小时。对于不受轴向径向载荷的电机，其轴承寿命至少为 40000 小时。请务必按照电机铭牌或技术文档中规定的润滑脂型号对轴承进行润滑，加注油脂量和润滑周期见下表。加注润滑脂时应旋转电机轴以使润滑脂均匀分布。

极数	机座号	持久润滑型轴承的润滑脂	可再润滑型轴承的润滑脂	再润滑周期(小时)	加注油脂量(克)
2~6	80	标配	-/-	-/-	-/-
2~6	90	标配	-/-	-/-	-/-
2~6	100	标配	-/-	-/-	-/-
2~6	112	标配	-/-	-/-	-/-
2~8	132	标配	-/-	-/-	-/-
2	160	-/-	标配	4000 h	10g
4~8		-/-	标配	8000 h	10g
2	180	-/-	标配	4000 h	20g
4~8		-/-	标配	8000 h	20g
2	200	-/-	标配	4000 h	20g
4~8		-/-	标配	8000 h	20g
2	225	-/-	标配	4000 h	20g
4~8		-/-	标配	8000 h	20g
2	250	-/-	标配	4000 h	25g
4~8		-/-	标配	8000 h	25g
2	280	-/-	标配	4000 h	25g
4, 6, 8		-/-	标配	5000 h	30g
2	315	-/-	标配	3000 h	40g
4		-/-	标配	4000 h	40g
6, 8		-/-	标配	6000 h	40g
2	355	-/-	标配	3000 h	30g
4		-/-	标配	4000 h	60g
6, 8		-/-	标配	6000 h	60g

使用防爆认证带“X”标记的防爆电机时，对于隔爆型“db 或 d”电机，只能在遵守制造商设计说明的情况下才能维修该产品。不允许按照 GB/T 3836.2

(IECIEN60079-1) 中的标准值进行维修。

REACH 法规第 33 条的规定

该产品的一个或多个组成物中含有高关注物质候选清单中的以下物质超过 0.1%:

CAS 编号 7439-92-1, 铅

基于现有信息，在规范化使用的条件下，包括废弃处理，该物质不会产生风险。未经茵梦达授权，禁止擅自改装电机，否则保修将无效。

5.4 隔爆结构示意图

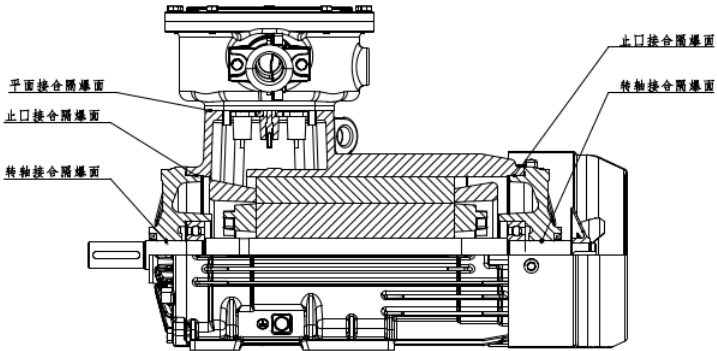

FS80-132 电机装配图

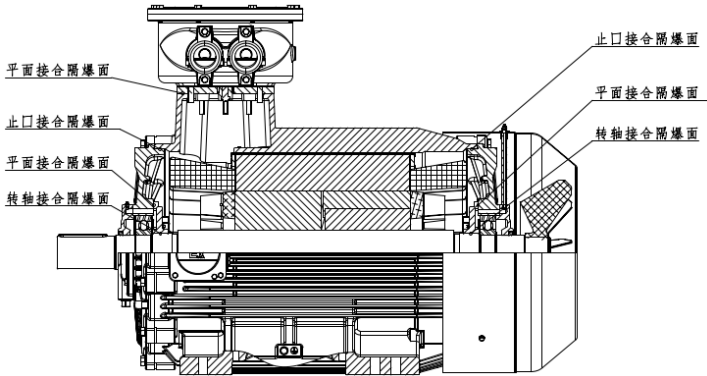

FS160-355 电机装配图

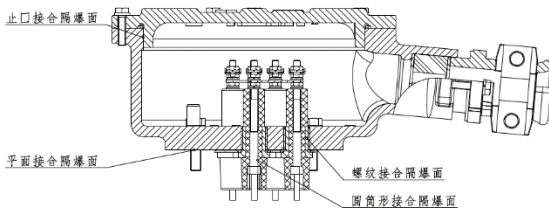

FS80-225 接线盒装配图

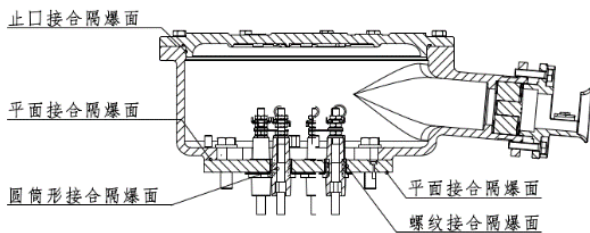

FS250-280 接线盒装配图

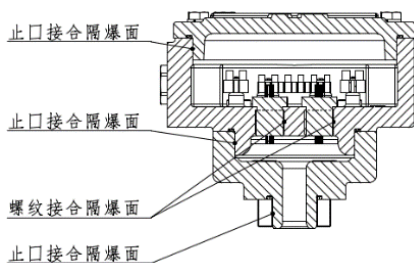

FS160-355 辅助接线盒装配图

- 备注：1.若隔爆接合面损坏，不允许修理，必须更换
 2.维修隔爆面时，应联系原制造商获取有关隔爆接合面尺寸的信息
 3.该产品隔爆外壳紧固螺栓应保证抗拉强度 $\geq 800\text{MPa}$ ，屈服强度 $\geq 640\text{MPa}$

Contents

1 Safety information.....	24
1.1 The five safety rules.....	24
1.2 Qualified personnel.....	24
1.3 Electromagnetic fields when operating electric machines.....	24
1.4 Operating in hazardous area.....	25
2 Preparation before using.....	26
2.1 Application scope.....	26
2.2 Cooling method.....	27
2.3 Mounting and construction type.....	27
2.4 Delivery and storage.....	27
2.5 Model naming explanation and specification code description.....	30
3 Installation.....	31
3.1 Preparing installation place.....	31
3.2 Ensure adequate cooling.....	31
3.3 Installing.....	33
3.4 Electric connection.....	34
3.5 Checking after connection.....	39
4 Start-up.....	40
4.1 Checking before start-up.....	40
4.2 Test run.....	40
5 Operation and maintenance.....	41
5.1 Safety information during operation.....	41
5.2 Operation.....	42
5.3 Inspection and maintenance.....	43
5.4 Flameproof structure diagram.....	45

1 Safety information

1.1 The five safety rules

For personal safety and to prevent damage, when carrying out any work, please always observe and obey safety instructions and the following five safety rules according to EN50110-1 "Working at voltage-free status". Apply the five safety rules in the sequence stated.

- (1) Disconnect the system, including auxiliary circuits, for example, anti-condensation heaters.
- (2) Make sure circuits not being re-connected coincidentally.
- (3) Verify no voltage on equipment.
- (4) Connect grounding and short-circuit.
- (5) Cover or isolate adjacent live parts.

Energy the system by recover the measures in reverse order.

1.2 Qualified personnel

All work on the machine must only be carried out by qualified personnel. For the purpose of this document, qualified personnel mean people who fulfill following requirements:

- Through appropriate training and experience, be able to recognize and avoid risks and potential dangers in responsibility.
- Must be appointed by responsible person.

1.3 Electromagnetic fields when operating electric machines

Electronic devices may be interfered by electric machines. Electromagnetic fields will be generated during electric machines' operating. Potentially lethal malfunctions can occur on medical implants, e.g. pacemakers, in the surrounding area of electric machines. Data may be lost in magnetic or digital data carriers.

- It is forbidden for people with pacemakers to stay nearby the machine.
- Take proper measures to protect personnel working in the plant. For example, making signs, safety barriers, setting safety instructions and markings.
- Obey safety and labor protection laws and regulations.
- Do not put magnetic and digital data media near electric machines.

This motor fulfills standard GB755 (IEC/EN60034-1). When used as prescribed, it complies with electromagnetic compatibility requirements.

1.4 Operating in hazardous area

Electric machines in hazardous area must be installed, commissioned, and operated only by qualified personnel, and must follow valid regulations.

Note

Requirements of electric machines and operation in hazardous area can refer to standard GB 3836.15 (IEC/EN60079-14).

Users shall consult with local supervisor departments for evaluating area conditions and equipment risks, and to define necessary monitoring and control methods. These methods shall be organized as regulations and must be obeyed at any condition. Because of the variability of local conditions, motor manufacturer cannot provide universally applicable advices.

Note

Assessment of electric machines and hazardous areas can refer to series standard GB/T3836 (IEC/EN60079).

For motors with third-party certifications, certified technical specifications and special conditions are fulfilled. Certification documents shall be observed.

For enclosure flameproof “db or d” Ex motors with marking “X” in certification number, repairing can only be taken according to manufacturers’ instructions. Repairing according to standard values in GB/T3836.2 (IEC/EN60079-1) is not allowed.

2 Preparation before using

2.1 Application scope

1MT8004/1MT8005 series enclosure flameproof motor's designing and manufacturing fulfills standards GB/T3836.1 "Explosive atmospheres - Part 0: Equipment - General requirements" (IEC/EN60079-0) and GB/T3836.2 "Explosive atmospheres - Part 1: Equipment protection by flameproof enclosures "d" (IEC/EN60079-1). It is applicable to work in category II class B hazardous gas area.

1MT8004/1MT8005 motor fulfills of GB18613 "Minimum allowable values of energy efficiency and energy efficiency grades for small and medium three-phase asynchronous motors".

1MT8004 fulfills energy level grade 2;

1MT8005 fulfills energy level grade 1.

For energy efficiency of specific motor type, please refer to nameplate.

Motor's working condition is altitude within 1000m, ambient temperature -20 °C~ +40 °C. Option D03 ambient temperature -40 °C ~ +40 °C. Option N05, N06, N07 and N08 ambient temperature -20°C ~ +60°C. Explosion-proof mark Ex db IIB T4 Gb. When the product uses an purchased cable introduction device, it should be compatible with the overall operating environment of the machine and obtain explosion-proof certification.

Voltage frequency:

220V/380V 50Hz、230V/400V 50Hz、240V/415V 50Hz、380V/660V 50Hz、
400V/690V 50Hz、220V 50Hz、230V 50Hz、240V 50Hz、380V 50Hz、400V 50Hz、
415V 50Hz、440V 50Hz、460V 50Hz、480V 50Hz、500V 50Hz、575V 50Hz、
660V 50Hz、690V 50Hz、220V/380V 60Hz、230V/400V 60Hz、240V/415V 60Hz、
380V/660V 60Hz、400V/690V 60Hz、220V 60Hz、230V 60Hz、240V 60Hz、
380V 60Hz、400V 60Hz、415V 60Hz、440V 60Hz、460V 60Hz、480V 60Hz、
500V 60Hz、575V 60Hz、660V 60Hz、690V 60Hz。

Enclosure protection grade: IP55/IP56/IP65/IP66.

Motor profile:

1MT8004-0DA2, 1MT8004-0DA3, 1MT8004-0DB2, 1MT8004-0DB3, 1MT8004-0DC3,
1MT8004-0EA0, 1MT8004-0EA4, 1MT8004-0EB0, 1MT8004-0EB4, 1MT8004-0EC0,
1MT8004-0EC4, 1MT8004-1AA4, 1MT8004-1AB4, 1MT8004-1AB5, 1MT8004-1AC4,
1MT8004-1BA2, 1MT8004-1BB2, 1MT8004-1BC2, 1MT8004-1CA0, 1MT8004-1CA1,
1MT8004-1CB0, 1MT8004-1CB2, 1MT8004-1CC0, 1MT8004-1CC2, 1MT8004-1CC3,
1MT8004-1CD0, 1MT8004-1CD2, 1MT8004-1DA2, 1MT8004-1DA3, 1MT8004-1DA4,
1MT8004-1DB2, 1MT8004-1DB4, 1MT8004-1DC2, 1MT8004-1DC4, 1MT8004-1DD2,
1MT8004-1DD3, 1MT8004-1DD4, 1MT8004-1EA2, 1MT8004-1EB2, 1MT8004-1EB4,
1MT8004-1EC4, 1MT8004-1ED4, 1MT8004-2AA4, 1MT8004-2AA5, 1MT8004-2AB5,
1MT8004-2AC4, 1MT8004-2AC5, 1MT8004-2AD5, 1MT8004-2BA2, 1MT8004-2BB0,
1MT8004-2BB2, 1MT8004-2BC2, 1MT8004-2BD0, 1MT8004-2BD2, 1MT8004-2CA2,

1MT8004-2CB2, 1MT8004-2CC2, 1MT8004-2CD2, 1MT8004-2DA0, 1MT8004-2DA2, 1MT8004-2DB0, 1MT8004-2DB2, 1MT8004-2DC0, 1MT8004-2DC2, 1MT8004-2DD0, 1MT8004-2DD2, 1MT8004-3AA0, 1MT8004-3AA2, 1MT8004-3AA5, 1MT8004-3AA6, 1MT8004-3AA7, 1MT8004-3AB0, 1MT8004-3AB2, 1MT8004-3AB5, 1MT8004-3AB6, 1MT8004-3AB7, 1MT8004-3AC0, 1MT8004-3AC2, 1MT8004-3AC5, 1MT8004-3AC6, 1MT8004-3AD0, 1MT8004-3AD2, 1MT8004-3AD5, 1MT8004-3AD6, 1MT8004-3BA2, 1MT8004-3BA3, 1MT8004-3BA5, 1MT8004-3BA6, 1MT8004-3BB2, 1MT8004-3BB3, 1MT8004-3BB5, 1MT8004-3BB6, 1MT8004-3BC2, 1MT8004-3BC3, 1MT8004-3BC4, 1MT8004-3BC5, 1MT8004-3BC6, 1MT8004-3BD2, 1MT8004-3BD3, 1MT8004-3BD5, 1MT8004-3BD6

1MT8005-0DA2, 1MT8005-0DA3, 1MT8005-0DB2, 1MT8005-0DB3, 1MT8005-0DC3, 1MT8005-0EA0, 1MT8005-0EA4, 1MT8005-0EB0, 1MT8005-0EB4, 1MT8005-0EC0, 1MT8005-0EC4, 1MT8005-1AA4, 1MT8005-1AB4, 1MT8005-1AB5, 1MT8005-1AC4, 1MT8005-1BA2, 1MT8005-1BB2, 1MT8005-1BC2, 1MT8005-1CA0, 1MT8005-1CA1, 1MT8005-1CB0, 1MT8005-1CB2, 1MT8005-1CC0, 1MT8005-1CC2, 1MT8005-1CC3, 1MT8005-1CD0, 1MT8005-1CD2, 1MT8005-1DA2, 1MT8005-1DA3, 1MT8005-1DA4, 1MT8005-1DB2, 1MT8005-1DB4, 1MT8005-1DC2, 1MT8005-1DC4, 1MT8005-1DD2, 1MT8005-1DD3, 1MT8005-1DD4, 1MT8005-1EA2, 1MT8005-1EB2, 1MT8005-1EB4, 1MT8005-1EC4, 1MT8005-1ED4, 1MT8005-2AA4, 1MT8005-2AA5, 1MT8005-2AB5, 1MT8005-2AC4, 1MT8005-2AC5, 1MT8005-2AD5, 1MT8005-2BA2, 1MT8005-2BB0, 1MT8005-2BB2, 1MT8005-2BC2, 1MT8005-2BD0, 1MT8005-2BD2, 1MT8005-2CA2, 1MT8005-2CB2, 1MT8005-2CC2, 1MT8005-2DA0, 1MT8005-2DA2, 1MT8005-2DB0, 1MT8005-2DB2, 1MT8005-2DC0, 1MT8005-2DC2, 1MT8005-3AA0, 1MT8005-3AA2, 1MT8005-3AA5, 1MT8005-3AA6, 1MT8005-3AA7, 1MT8005-3AB0, 1MT8005-3AB2, 1MT8005-3AB5, 1MT8005-3AB6, 1MT8005-3AB7, 1MT8005-3AC0, 1MT8005-3AC2, 1MT8005-3AC5, 1MT8005-3AC6, 1MT8005-3BA2, 1MT8005-3BA3, 1MT8005-3BA5, 1MT8005-3BA6, 1MT8005-3BB2, 1MT8005-3BB3, 1MT8005-3BB5, 1MT8005-3BB6, 1MT8005-3BC2, 1MT8005-3BC3, 1MT8005-3BC4, 1MT8005-3BC5, 1MT8005-3BC6

2.2 Cooling method

The standard cooling method is self-ventilation with fan according to IC411 in GB1993 (IEC/EN60034-6).

Warning

Motor over-heating

Damage, serious injury, or death may occur if motor is over-heating.

- Do not block ventilation.
 - Prevent adjacent machines' expelled gas being sucked into motor's fan.
 - If motor installed vertically with fan upward, prevent objects and water fall into fan.
 - If motor installed vertically with drive end upward, prevent liquid flow on shaft.
-

2.3 Mounting and construction type

Motor's mounting and construction type fulfills the standard GB/T997

"Rotating electrical machines - Classification of types of construction and mounting arrangements (IM Code)" (IEC/EN60034-7). It is stamped on motor's nameplate.

2.4 Delivery and storage

Check cargo's completeness immediately when receiving.

- Report any transportation damage to delivery agent immediately.
- Report any defect/missing to Innomotis office immediately.

Note

Motor damage

Motor may be damaged if incorrectly stored.

Protection methods should be taken under critical climate conditions (e.g. salty/dusty, moisture environment).

Storage place should be horizontal, stable, and dry. Put the motor on pallet, wood block, or foundation to prevent moisture. Avoid sinking into ground. Covers or tarpaulins used to protect against weather must not contact machine's surface.

Avoid influence from critical climate. Storage place should be dry, well-ventilated, and avoid dust, frozen, impact, or severe vibration.

When store the motor for a long period (≥ 6 month), anti-corrosion methods must be taken to bare metal surfaces.

Warning

Explosion may occur if sealing material damaged

If motor is stored at exceeded temperature, sealing materials may be damaged due to temperature. Explosive gas and dust may leak into the motor and result to explosion.

This may cause damage, serious injury, or death.

Conditions for storage:

Allowed ambient temperature: $-20\text{ }^{\circ}\text{C} \sim +50\text{ }^{\circ}\text{C}$

Allowed relative humidity: 60%

If the motor has special design for special ambient temperature, humidity, or altitude, its storage conditions may be different. In this case, please refer to the environment conditions on nameplate.

Period for storage:

Motor shaft shall be turned at least once a half year to avoid brinelling. Long-term storage will shorten bearing grease lifetime.

For the motor with closed-type bearings, after two years storage, bearings should be replaced before using; for the motor with open-type bearings, after two years storage, new grease should be added before using. Bearing grease type, re-greasing quantity, and intervals can refer to nameplate.

2.5 Model naming explanation and specification code description

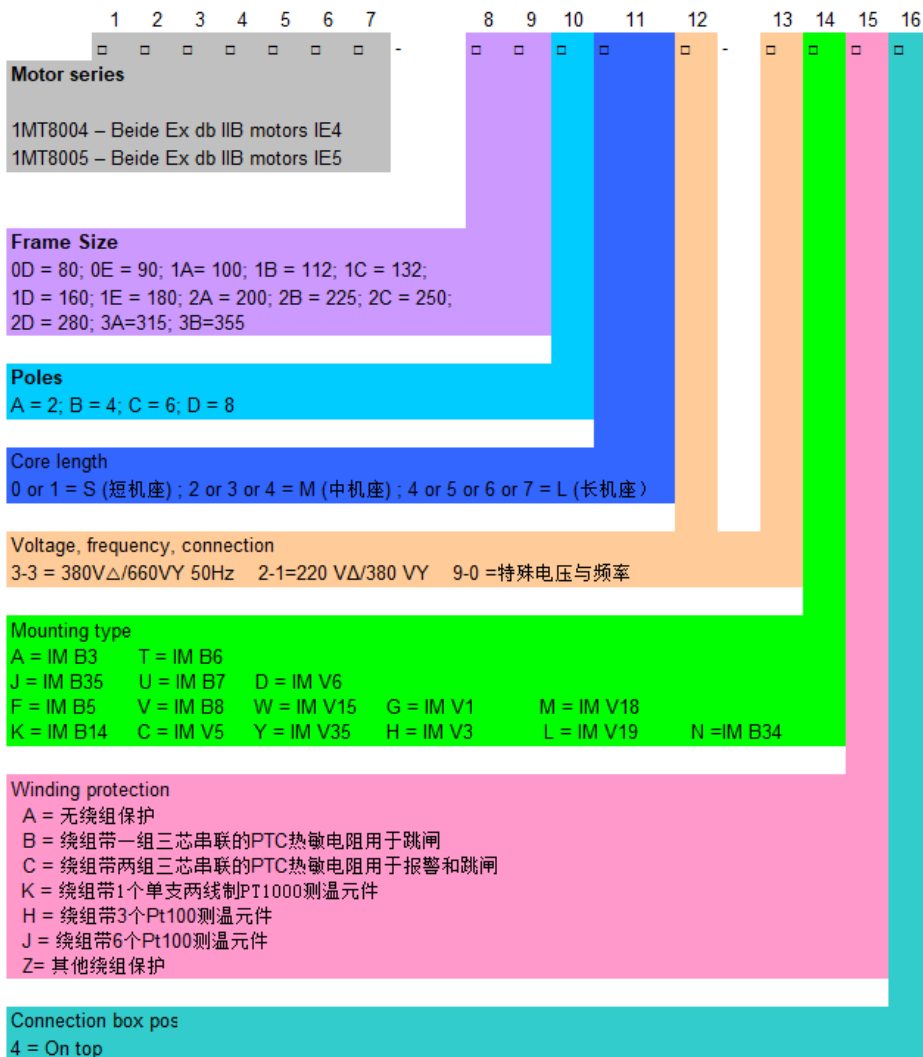

3 Installation

3.1 Preparing installation place

The motor can be installed on the foundation of metal or concrete base. The foundation should have sufficient stiffness and strength to support the motor. General flatness for motor installation foundation:

Frame size (FS)	Flatness (mm)
≤ 132	0.10
160	0.15
≥ 180	0.20

The motor installation location should avoid exposing to long-time direct sunlight, rain, snow and ice.

For the motor installed vertically with drive end downward, should take protection measures to prevent objects falling into fan; for the motor installed vertically with drive end upward, should prevent liquid flowing along the shaft.

Ex motors must only be used in allowed environment.

3.2 Ensure adequate cooling

Warning

Motor overheating

Pay attention to following points, otherwise damage, serious injury, or death may occur.

- Do not block ventilation.
 - Prevent the air expelled by nearby equipment from being immediately sucked in.
 - For vertically installed machines with air entry upward, prevent foreign objects and water falling into openings.
 - For vertically installed machines with shaft extension upward, prevent liquid from flowing into motor along the shaft.
-

For motors equipped with separately driven fans, please design the power circuit so as the motor cannot start-up when the separately driven fan is not running. Considering the air flow, please refer to following table when installing motors.

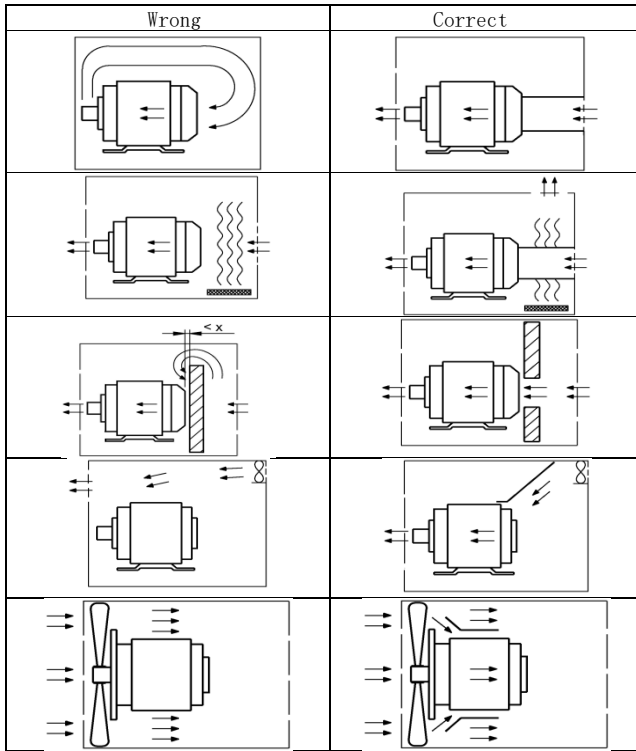

The minimum distance between motor fan cover and adjacent object "X" is shown below:

Frame size	X (mm)
80...100	20
112	25
132	30
160	40
180...200	90
225...250	100
280...315	110
355	140

3.3 Installing

When assembling or dis-assembling transmission elements (like coupling, gear, or pulley), proper tools shall be used. Use heating assembly if necessary. Do not hit with hammers. The axial and radial loads applied on shaft extension must not exceed the maximum allowed values in catalogue.

Because of machining and assembly tolerances, there may be gap between motor feet and installation foundation. Please measure this gap, if it is over 0.05mm, please insert filling plates. The size of plates is determined according to the size of gap.

When the installation bolt head interferes with the outer surface of the motor, please lift the motor away from the mating flange surface. First, the bolt through the flange installation hole, tighten the bolt to a position where the head does not interfere with the motor, connect the flange, and then tighten the installation bolt.

Warning

Motor falling

Damage, serious injury, or death may occur if motor falls.

- Check whether all eyebolts are tightened before lifting.
- Must use all eyebolts on the motor for lifting.
- Must use qualified hoisting tools and ropes for lifting.

If not specified, usually fasteners at least grade 8.8 according to GB/T3098.1 (ISO898-1) shall be used to fix and secure the motor.

The accuracy of alignment between motor and driven machine depends on the whole transmission system. The accuracy required by coupling manufacturer must be fulfilled.

Motor's rotor is dynamically balanced. Only finished machined and balanced driven element is allowed to use. Must use proper tools to assemble and dis- assemble the transmission element. The driven element should be assembled by using the thread hole on shaft end or by hand in one time. Do not use hammer, otherwise bearings may be damaged.

Warning

Key throwing-out

Damage, serious injury, or death may occur if key thrown-out

- The key is only secured during transportation. If the motor start-up without transmission element, the key may be thrown out during rotating.
- Please take measures to fix and secure the key on motor shaft if driven

element is not assembled. Thus to prevent the key from throwing out.

Remark: The type of frequency converter used in the test of this product is SINAMICS G120 PM240-2. The similar frequency converter of this series should be used when the motor is used.

3.4 Electric connection

Danger

Dangerous voltage

Damage, serious injury, or death may occur.

- All connection can only be made by qualified professional personnel on static motor.
 - Disconnect power source and make sure it cannot be re-connected coincidentally, including auxiliary circuits.
 - Verify no voltage on the motor!
 - Make reliable protection connection before working!
 - Deviations between actual values and rated voltage, frequency, and phase can result to temperature rising. Meanwhile influent electromagnetic compatibility.
 - Normally it is forbidden to operate non-grounded motor. Only in very rarely situations can be operated for very short time, for example when doing fault checking.
-

For the terminal box using hoop glands, the cable's diameter must matches with the hole diameter of the rubber sealing ring. Dimensions are as the following table. When the ambient temperature is 40 ° C ~ 60 ° C, for Option N05, N06, N07, N08 , the cable with a temperature resistance of not less than 98 ° C should be selected.

Warning

When opening the connection box cover, do not knock or pry to prevent damage to the flameproof surface.

The two threaded holes arranged on the junction box cover should be evenly threaded using longer screws to assist in the removal of the junction box cover. After the connection is complete, when closing the junction box cover, restore and tighten the two short screws here to prevent the protection level from being affected.

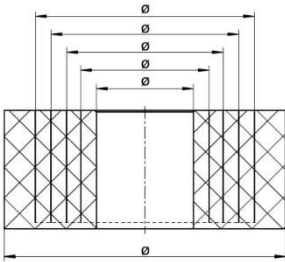

Frame size	Sealing ring hole diameter (mm)	Cable diameter (mm)
80~132	14	13
	20	19
	25	24
160~180	14	13
	20	19
	26	25
	31	30
200~280	35	34
	20	19
	26	25
	32	31
315~355	38	37
	42	41
	31	30
	36	35
315~355	45	44
	50	49
	60	59
	70	69

For the terminal box with auxiliary cable entries, and the terminal box using glands, thread holes are provided on terminal box. The size and number of thread hole refer to catalogue. Standard motors are delivered with these thread holes sealed by qualified plugs. Only the gland, adapter, or plug with appropriate Ex certifications is allowed to use.

When connecting cables and terminals inside the terminal box, make sure the connection is tight and stable. Recommended tightening torque refers to following table.

Terminal bolt size	M4	M5	M6	M8	M10	M12	M16	
Torque (Nm)	Min.	1	1.6	2.5	5	8	13	25
	Max.	1.2	2	3	6	10	15.5	30

Please refer to following table for external earthing bolt size and terminal box earthing bolt size.

Frame size	80-90	100-132	160	180	200-225	250-280	315-355
External earthing bolt size	M6	M8	M8	M12	M12	M12	M12
Terminal box earthing bolt size	M5	M5	M6	M6	M8	M10	M12

1 tri-wire PTC	15 th digit is B	2TP1
		2TP2
2 tri-wire PTC	15 th digit is C	1TP1
		1TP2
		2TP1
		2TP2
3 bi-wire Single-lead PTC	15 th digit is H	1R1
		1R2
		2R1
		2R2
		3R1
		3R2
6 bi-wire Single-lead PTC	15 th digit is J	1R1
		1R2
		2R1
		2R2
		3R1
		3R2
		4R1
		4R2
		5R1
		5R2
		6R1
		6R2
1 bi-wire Single-lead PTC	Option code Q35	1R1
		1R2
2 bi-wire Single-lead PTC	Option code Q36	1R1
		1R2
		2R1
		2R2
3 bi-wire Single-lead PTC	Option code Q63	1R1
		1R1
		1R2
		2R1
		2R1
		2R2
		3R1
		3R1
		3R2
		1R1

6 bi- wire Single-lead PTC	Option code Q64	1R1
		1R2
		2R1
		2R1
		2R2
		3R1
		3R1
		3R2
		4R1
		4R1
		4R2
		5R1
		5R1
		5R2
		6R1
6R1		
6R2		

Motor bearing temperature protection:

2 bi- wire Single-lead PTC	Option code Q72	10R1
		10R2
		11R1
		11R2
2 tri- wire Single-lead PTC	Option code Q78	10R1
		10R1
		10R2
		11R1
		11R1
2 tri- wire double-lead PTC	Option code Q79	11R2
		10R1
		10R1
		10R2
		11R1
		11R1
		11R2
		12R1
		12R1
		12R2
		13R1
13R1		
13R2		

The connection terminal for anti-condensation heater is 1HE1 and 1HE2.

Remark:

1. Motor winding temperature protection, PTC, PT100&PT1000, advise temperature alarming 145 °C or tripping function 155 °C.
2. Motor bearing temperature protection, PT100, advise temperature alarming 95 °C or tripping function 105 °C.
3. In order to ensure the reliable operation of the cable and seal ring, it is necessary to select the appropriate cable according to the rated current of the motor, and ensure that the maximum operating temperature at the entrance of the cable entry device and the cable branch point does not exceed 70°C and 80°C respectively. Above this temperature should consider replacing the cable, and contact the manufacturing unit to confirm suitability.

When delivered, the thread holes on terminal box are sealed with qualified plugs.

After connection, unused holes shall remain sealed.

Grounding points inside terminal box and on frame outside surface must be reliable grounded.

It is recommended that the user set the electrical protection matching the motor in accordance with the requirements of GB 3836.15.

3.5 Checking after connection

Check following items after connection:

- Electric connection is completed according to previous instruction and tightened with proper torque.
- Electric clearance between non-insulated parts.
- No remaining wires.
- Connection is made so as the motor will rotate on correct direction.
- Keep terminal box inside clean, no foreign parts or objects remain.
- All sealing parts and joint surfaces must keep clean, and without damage.
- Unused cable entries must keep sealed.
- All grounding points are well connected.

4 Start-up

4.1 Checking before start-up

After installation and connection, check following items before commissioning:

- Motor is not damaged.
- Motor is installed and aligned as needed; driven elements are correctly balanced and assembled.
- All fasteners and connection parts are tightened.
- Motor's working conditions are allowed according to requirements, for example hazardous area category, IP protection level, ambient temperature.
- Moving parts, like couplings, can rotate freely.
- All active parts and live parts are protected.

4.2 Test run

Carry out a test run after installation:

(1) Start up the motor without load; check rotation direction.

(2) If motor runs normally, then connect load.

(3) Check and record following data:

- Check noise and vibration during motor running.
- Record voltage, current, and power.
- Use available equipment to measure temperature in bearings and windings.

(4) If motor runs unstably or makes abnormal noise, switch off immediately.

And try to determine the problem during motor's slowing down:

- If noise or vibration obviously becomes better, the problem could be of electromagnetic issues.
- If noise or vibration does not change, the problem could be of mechanical issues. Possible causes include unbalance, misalignment, and resonance.

(5) If the motor is equipped with separately driven fan, this separately fan rotation direction should be checked during test run.

5 Operation and maintenance

5.1 Safety information during operation

Danger

Dangerous voltage

Damage, serious injury, or death may occur.

Electric machines have dangerous voltage, if contact machine surface, terminals, or other positions, dangers may occur.

Warning

Malfunctions during operation

Abnormal situation indicates that there may be malfunctions on the motor. These may cause damage, serious injury, or death. Please take care of following situations:

- Higher power consumption than usual
 - Higher temperature than usual
 - Abnormal noise
 - Abnormal vibration
 - Abnormal smells
 - Response from monitoring devices
-

Note

Motor damage or short bearing lifetime

- Please absolutely maintain the permissible vibration, avoid unstable environment or impact. Thus to prevent bearings from damage.
 - Do not exceed the permissible axial and radial load values in catalogue.
 - When powered by converter, take measures to reduce bearing current.
-

Note

Corrosion risks resulting from condensation

The changing of motor temperature or ambient temperature may cause condensation inside the motor. If the motor is equipped with anti-condensation heater, please make sure the heater is powered on when the motor is switched off.

Note

Motor over-heating

If the motor is equipped with anti-condensation heater, please make sure the heater is switched off before starting the motor.

If the motor is equipped with cylindrical roller bearings, during no-load operation the bearing easy to slip and the bearing noise is large. In the early stage of skidding, there may be obvious adhesion and trailing marks on the bearing raceway, so it is recommended to shorten the no-load running time or increase the radial preload force.

5.2 Operation

If possible, please start the motor without load and check noise. Use available equipment to check motor's temperature and vibration.

Note

Overload of motor direct-on-line

In addition to the load torque, motor's starting time is also influenced by moment inertial. When starting up, the current can be several times of rated current. This can result to over-heating and damage. So please take care of following items when starting up

- Please comply with the limit values and conditions defined in catalogue and technical documents.
 - Monitor the ramp-up time every time to check whether abnormal issue happens.
-

If the motor is equipped with separately driven fan, do not switch off this fan immediately when motor is powered off. Please wait for the motor to cool down. This can prevent the accumulation of residual heat.

For long-time stoppage (over 1 month), run the machine once a month, or at least turn the rotor.

If the motor is stopped for over 12 month, please take proper measures of anti-corrosion, package, and drying; thus to prevent the motor from damage. Before starting again, please go through the checking and run steps in Chapter 5.

5.3 Inspection and maintenance

Danger

Danger Explosion hazards from static-electricity Damage, serious injury, or death may occur. When cleaning, non-metal parts may generate static- electricity and ignite explosive substances. This may cause explosion.

- Do not execute cleaning in explosive atmosphere.
 - Avoid static accumulation when cleaning non-metal parts.
 - Do not use compressed air for cleaning.
-

Warning

It is strictly forbidden to open the lid with electric power, and all work must be operated by skilled workers. Before the motor does any operating work, ensure that the motor is disconnected from the main line and auxiliary power supply, and ensure that the power supply is not accidentally turned on.

After new motor's 500-hour-operation or 1-year-after-installation, please make the first time inspection:

- Whether rated electrical characteristics still remain.
- Whether bearings' temperature is still in permissible scope.
- Whether motor runs steady and smoothly.
- Whether there is crevice or deform of installation foundation.

According to the system, other items may also need to check.

After every 16000-hour-operation or 2-years-after-inspection, please make the following regular inspection:

- Whether rated electrical characteristics still remain.
- Whether bearings' temperature is still in permissible scope.
- Whether motor runs steady and smoothly.
- Whether there is crevice or deform of installation foundation.
- Whether alignment is still in valid tolerance.
- Whether all fasteners and connections are tightened.
- Whether all equipotential, grounding, and shield connections are connected and in contact.
- Whether the winding's insulation resistance is enough.
- Whether cables, sealings, and insulations are in good status, without discoloring.

When the motor undertakes the maximum allowed loads stated in catalogue, the guaranteed bearing life is at least 20000h. If the motor operates without load on shaft extension, the bearing life is at least 40000h. Please re-grease bearings according to the grease type, grease quantity, and instructed on nameplate or technical documents. Please following up the table. about the grease quantity and intervals. When adding grease, please rotate motor's rotor so new grease can distribute inside bearings.

Number of Poles	Frame Size	Permanent lubrication	Re-greasing	Re greasing(h)	Re-greasing(g)
2~6	80	Standard	-/-	-/-	-/-
2~6	90	Standard	-/-	-/-	-/-
2~6	100	Standard	-/-	-/-	-/-
2~6	112	Standard	-/-	-/-	-/-
2~8	132	Standard	-/-	-/-	-/-
2	160	-/-	Standard	4000 h	10g
4~8		-/-	Standard	8000 h	10g
2	180	-/-	Standard	4000 h	20g
4~8		-/-	Standard	8000 h	20g
2	200	-/-	Standard	4000 h	20g
4~8		-/-	Standard	8000 h	20g
2	225	-/-	Standard	4000 h	20g
4~8		-/-	Standard	8000 h	20g
2	250	-/-	Standard	4000 h	25g
4~8		-/-	Standard	8000 h	25g
2	280	-/-	Standard	4000 h	25g
4, 6, 8		-/-	Standard	5000 h	30g
2	315	-/-	Standard	3000 h	40g
4		-/-	Standard	4000 h	40g
6, 8		-/-	Standard	6000 h	40g
2	355	-/-	Standard	3000 h	30g
4		-/-	Standard	4000 h	60g
6, 8		-/-	Standard	6000 h	60g

Enclosure flameproof motors with marking "X" in certification can only be repaired according to manufacturer's instruction. It is forbidden to repair according to standard values in GB/T3836.2 (IEC/EN60079-1).

Information according to Article 33 of the REACH regulation

This product contains one or several subproducts in which the following substance -belonging to the "list of restrictions" - exists in a concentration exceeding 0.1 percent by weight.

- CAS No. 7439-92-1, lead

Based on currently available information, this substance does not represent any risk when correctly used, including its disposal.

Unauthorized changes or modifications to the motor are forbidden and will break the

warranty.

5.4 Flameproof structure diagram

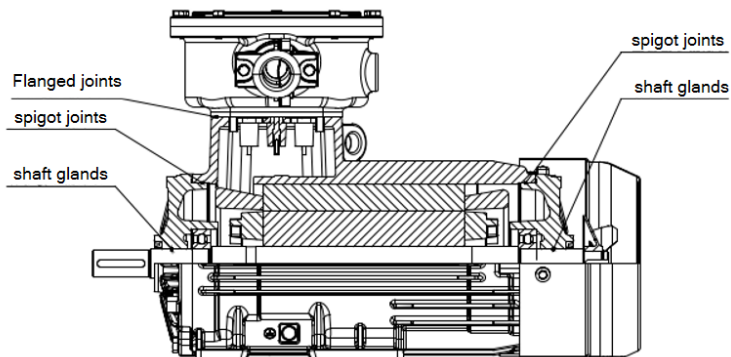

FS80-132 assembly drawing

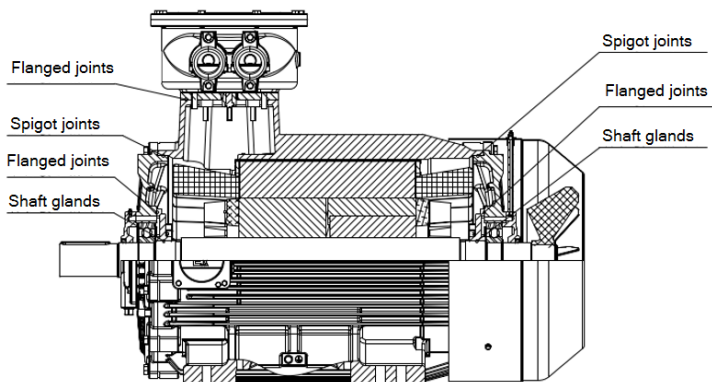

FS160-355 assembly drawing

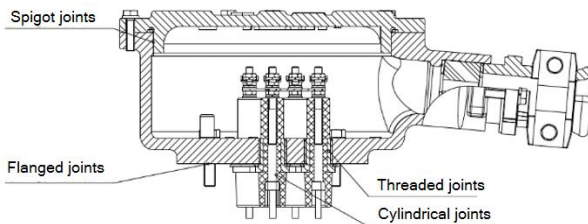

FS80-225 terminal box assembly drawing

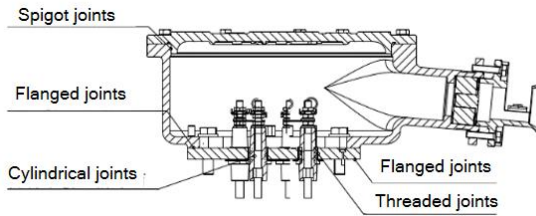

FS250-280 terminal box assembly drawing

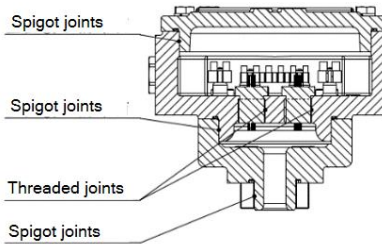

FS160-355 auxiliary terminal box assembly drawing

Remarks:

1. If the flameproof joint surface is damaged, it is not allowed to repair, and the parts must be replaced.
2. When repairing flameproof surfaces, contact the original manufacturer for information on the dimensions of flameproof joints.
3. The fastening bolts of the flameproof shell of the product should ensure that the tensile strength is greater than 800MPa and the yield strength is greater than 640MPa.

贝得电机的服务范围仅限中国大陆地区

The service area of Beide motor is in China mainland

本公司产品服务由当前服务商或售后服务部负责

Product service is provided by current service agent or post-sale department



售后支持

After-sales support

本手册中提供的信息只是对产品的一般说明和特性介绍。文中内容可能与实际应用的情况有所出入，并且可能会随着产品的进一步开发而发生变化。仅当相关合同条款中有明确规定时，茵梦达方有责任提供文中所述的产品特性。手册中涉及的所有名称可能是茵梦达公司或其供应商的商标或产品名称，如果第三方擅自使用可能会侵犯所有者的权利。