

1MT8014 系列粉尘防爆型三相异步电动机

1MT8014 Series Dust Explosion-proof  
Three-phase Asynchronous Motor

**使用维护说明书**

**INSTRUCTIONS**

**茵梦达电机（中国）有限公司**

Innomotics Standard Motors Ltd.

2026.05



# 目录

<b>1 安全信息</b> .....	<b>1</b>
1.1 五条安全原则 .....	1
1.2 合格人员 .....	1
1.3 使用电气设备时的电磁场 .....	1
1.4 在危险区域使用 .....	2
<b>2 使用前的准备</b> .....	<b>3</b>
2.1 应用范围 .....	3
2.2 冷却方式 .....	4
2.3 安装结构形式 .....	4
2.4 运输和保存 .....	4
2.5 型号命名解释及规格代码说明 .....	6
<b>3 安装</b> .....	<b>7</b>
3.1 准备安装区域 .....	7
3.2 确保合理的冷却 .....	7
3.3 安装 .....	9
3.4 电气连接 .....	10
3.5 连接后的检查 .....	12
<b>4 启动</b> .....	<b>13</b>
4.1 启动前的检查 .....	13
4.2 试运行 .....	13
<b>5 运行和维护</b> .....	<b>14</b>
5.1 运行中的安全提示 .....	14
5.2 运行 .....	18
5.3 检查和维修 .....	18
5.4 密封结构图 .....	20
<b>6 废弃物处理</b> .....	<b>21</b>
6.1 RoHS - 特定危险材料的使用限制 .....	21
6.2 REACH 法规第 33 条的规定 .....	21
6.3 拆卸的准备工作 .....	22
6.4 拆解电机 .....	22
6.5 处理组件的废弃物 .....	22

# 安全信息

## 1.1 五条安全原则

开展作业时，为保障人身安全和避免财产损失，请始终遵守安全注意事项和下面符合 EN50110-1 “在无电压状态下工作”的五项安全规程。开始作业前请按照以下顺序实施五项安全规程。

- (1) 断电，包括断开辅助电路，例如防潮加热带等。
- (2) 确保不会意外通电。
- (3) 确认设备上已无电压。
- (4) 接地并短接。
- (5) 遮盖或隔离邻近的带电部件。

结束作业后按照相反的顺序取消上述措施。

## 1.2 合格人员

只允许由专业人员调试和操作设备。本文中涉及的专业人员必须满足以下前提条件：

- 必须接受过相关培训且具备相应经验，能够发现职责范围内的风险，避免发生危险。
- 必须是由负责人委任的相应人员进行作业。

## 1.3 使用电气设备时的电磁场

电气设备可干扰电子设备。电气设备在运行中会产生电磁场。在电机附近逗留可能会使医疗植入体，如心脏起搏器等，出现危及生命的故障。磁性或电子数据存储设备可能会发生数据丢失。

- 禁止佩戴心脏起搏器的人员在电机附近逗留。
- 采取适当措施，如设置标识、封锁工作区域、张贴安全须知和警示标志等，为在设备周围工作的人员提供充分的保护和提醒，防止其受到伤害。

- 请遵守所在地区的安全和劳保护规定。
- 请不要让磁性或电子数据存储设备靠近电机。

本电机符合 GB/T755 (IEC/EN60034-1) 标准, 在按照规定使用时满足关于电磁兼容性的要求。

## 1.4 在危险区域使用

在爆炸性环境中使用的电气设备必须由合格人员按照现行有效的规定进行安装、调试和操作。

---

说明

关于爆炸性环境中的电气设备及其运行的基本要求可查阅系列标准 GB/T3836。

---

设备使用者应咨询当地主管部门, 评估现场环境条件和设备操作风险, 以确定必要的监控措施, 并将这些措施制定为规定。在任何条件下都必须遵守这些规定。由于现场条件各有不同, 电机制造商无法提供普遍适用的建议。

---

说明

关于电气设备及爆炸性环境的评估方法, 可查阅系列标准 GB/T3836。

---

如果电机获得了第三方认证, 则表明电机符合其中所规定的技术数据和特殊条件, 应在调试前查看证书。

使用防爆认证带“X”标记的防爆电机时, 只能在遵守制造商设计说明的情况下才能维修该产品。

# 使用前的准备

## 2.1 应用范围

1MT8014 系列隔爆型三相异步电动机的设计和制造符合标准GB/T3836.1-2021《爆炸性环境 - 第1部分：设备通用要求》和 GB/T3836.31-2021《爆炸性环境 - 第31 部分：由防粉尘点燃外壳“t”保护的的设备》。防爆标志为 Ex tb IIIC T130°C Db。适用于粉尘爆炸性环境 21 和 22 区。该系列电机符合 GB18613《中小型三相异步电动机能效限定值及能效等级》中规定的能效等级 2 级（IEC/ EN60034-30 中的 IE4 能效等级）要求，具体规格电机的能耗指标参见电机上的铭牌。电机工作环境条件为海拔不超过 1000 米，环境温度范围 -20°C ~ +40°C。D03 选项时环境温度范围-40°C~+40°C，N05、N06、N07 和N08选项时环境温度范围-20°C~+60°C。连续工作制 S1。当产品使用外购的电缆引入装置时，其应与整机使用环境相适应且取得防爆认证。

涉及电压频率：

220V/380V 50Hz、230V/400V 50Hz、240V/415V 50Hz、  
380V/660V 50Hz、400V/690V 50Hz、220V 50Hz、230V 50Hz、  
380V 50Hz、400V 50Hz、415V 50Hz、440V 50Hz、460V 50Hz、  
480V 50Hz、500V 50Hz、575V 50Hz、660V 50Hz、690V 50Hz、  
220V/380V 60Hz、230V/400V 60Hz、380V/660V 60Hz、  
400V/690V 60Hz、220V 60Hz、230V 60Hz、380V 60Hz、  
400V 60Hz、415V 60Hz、440V 60Hz、460V 60Hz、480V 60Hz、  
500V 60Hz、575V 60Hz、660V 60Hz、690V 60Hz。

该产品外壳防护等级：IP65。

电机型谱：

1MT8014-1AA4、1MT8014-1AB4、1MT8014-1AB5、1MT8014-1AC4、  
1MT8014-1BA2、1MT8014-1BB2、1MT8014-1BC2、1MT8014-1CA0、  
1MT8014-1CA1、1MT8014-1CB0、1MT8014-1CB2、1MT8014-1CC0、

1MT8014-1CC2、1MT8014-1CC3、1MT8014-1CD0、1MT8014-1CD2、  
1MT8014-1DA2、1MT8014-1DA3、1MT8014-1DA4、1MT8014-1DB2、  
1MT8014-1DB4、1MT8014-1DC2、1MT8014-1DC4、1MT8014-1DD2、  
1MT8014-1DD3、1MT8014-1DD4、1MT8014-1EA2、1MT8014-1EB2、  
1MT8014-1EB4、1MT8014-1EC4、1MT8014-1ED4、1MT8014-2AA4、  
1MT8014-2AA5、1MT8014-2AB5、1MT8014-2AC4、1MT8014-2AC5、  
1MT8014-2AD5、1MT8014-2BA2、1MT8014-2BB0、1MT8014-2BB2、  
1MT8014-2BC2、1MT8014-2BD0、1MT8014-2BD2、1MT8014-2CA2、  
1MT8014-2CB2、1MT8014-2CC2、1MT8014-2CD2、1MT8014-2DA0、  
1MT8014-2DA2、1MT8014-2DB0、1MT8014-2DB2、1MT8014-2DC0、  
1MT8014-2DC2、1MT8014-2DD0、1MT8014-2DD2、1MT8014-3AA0、  
1MT8014-3AA2、1MT8014-3AA5、1MT8014-3AA6、1MT8014-3AA7、  
1MT8014-3AB0、1MT8014-3AB2、1MT8014-3AB5、1MT8014-3AB6、  
1MT8014-3AB7、1MT8014-3ACO、1MT8014-3AC2、1MT8014-3AC5、  
1MT8014-3AC6、1MT8014-3ADO、1MT8014-3AD2、1MT8014-3AD5、  
1MT8014-3AD6、1MT8014-3BA2、1MT8014-3BA3、1MT8014-3BA5、  
1MT8014-3BA6、1MT8014-3BB2、1MT8014-3BB3、1MT8014-3BB5、  
1MT8014-3BB6、1MT8014-3BC2、1MT8014-3BC3、1MT8014-3BC4、  
1MT8014-3BC5、1MT8014-3BC6、1MT8014-3BD2、1MT8014-3BD3、  
1MT8014-3BD5、1MT8014-3BD6

## 2.2 冷却方式

电机标配冷却方式为自扇冷式，符合 GB1993 中的 IC411 冷却方式（IEC/EN60034-6）。

如果使用带有独立驱动风扇的电机，冷却方式 IC416，请对电路进行设计以防止在独立风扇未运行时接通并运行主电机。

## 2.3 安装结构形式

电机的安装结构形式符合 GB/T997《旋转电机结构型式、安装型式及接线盒位置的分类（IM 代码）》（IEC/EN60034-7）。电机铭牌上表示出了其安装结构形式。

## 2.4 运输和保存

- 收货后立即检查货物是否与随附单证相一致
- 立即向运输代理商报告任何明显的运输损坏。
- 如有明显缺失 / 不完整，应立即通知相应的茵梦达办事处。

---

注意

电机损坏

未按规定存放可能会损坏电机。

在极端气候条件下（如含盐和 / 或积尘、潮湿的环境），应采取适当的防护措施。

---

选择水平、稳固且干燥的存放位置。将电机、设备和包装箱放置在底架、大方木料或基座上，以防止地面湿气。防止电机陷入地下。防潮用的盖布或防雨布不得与所存放物品的表面接触。

应防止受极端天气的影响。存放位置应保持干燥、通风良好并且防尘、防冻、防撞、防止剧烈振动。

长期存放时（≥ 6 个月），须对裸露的金属表面采取适当的防腐措施。

---

#### 警告

密封材料损坏可能引发爆炸

在超出允许的环境温度下存放电机，可能导致密封材料因温度而损坏，导致密封失效。这可能让爆炸性气体和粉尘等异物进入电机，从而引发爆炸。这可能造成财产损失、重伤或死亡。

---

存放电机的环境条件：

允许的温度范围：-20°C ~ +50°C

允许的最大空气湿度：60%

对于环境温度、湿度或海拔有特殊要求的电机，其存放条件需遵守其它要求。此时请参考电机铭牌上对于环境条件的说明。

存放时间：

每月必须至少旋转电机轴 1 次，以避免振蚀。长期存放会降低轴承润滑脂的使用寿命。对于密封型轴承，在存放超过两年后，电机使用前应更换前后轴承；对于配备了再润滑装置的电机，在存放超过两年后，应向前后轴承注入新的润滑脂。可再润滑型轴承的润滑脂型号、加注油脂量和再润滑周期见电机铭牌。

选择水平、稳固且干燥的存放位置。将电机、设备和包装箱放置在底架、大方木料或基座上，以防止地面湿气。防止电机陷入地下。防潮用的盖布或防雨布不得与所存放物品的表面接触。

应防止受极端天气的影响。存放位置应保持干燥、通风良好并且防尘、防冻、防撞、防止剧烈振动。

长期存放时（≥ 6 个月），须对裸露的金属表面采取适当的防腐措施。

---

## 2.5 型号命名解释及规格代码说明

电动机订货号: Order No:

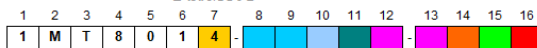

电机系列 Motor series

1MB801 - 麦罗达粉尘防爆电机 Innomotics Dust explosion proof motors

1MT801 - 贝得粉尘防爆电机 Beide Dust explosion proof motors

能效等级 Efficiency grade

4 = IE4, 中国能效等级2级 China Energy Efficiency Grade 2

机座号编号 Code of frame size

0D = 080 / 0E = 090

1A = 100 / 1B = 112 / 1C = 132 / 1D = 160 / 1E = 180

2A = 200 / 2B = 225 / 2C = 250 / 2D = 280

3A = 315 / 3B = 355

极数编号 Code of poles

A = 2 / B = 4 / C = 6 / D = 8

机座长度编号 Code of frame length

0 or 1 = S (短机座Short) / 2 or 3 or 4 = M (中机座Medium) / 4 or 5 or 6 or 7 = L (长机座Long)

电压, 连接方式和频率编号 Code of voltage, connections and frequency

21 = 220VD/380VY 50Hz	22 = 230VD/400VY 50Hz	35 = 415VD 50Hz
33 = 380VD/660VY 50Hz	23 = 240VD/415VY 50Hz	90 = 特殊电压与频率 special voltage & frequency
	34 = 400VD/690VY 50Hz	

结构和安装方式编号 Code of construction and mounting type

A = IM B3 J = IM B35

T = IM B6 V = IM B8

N = IM B34

W = IM V15

G = IM V1

M = IM V18

F = IM B5 K = IM B14

U = IM B7

C = IM V5

D = IM V6

Y = IM V35

H = IM V3

L = IM V19

绕组保护编号 Code of winding protection

A = 无绕组保护 without winding protection

B = 绕组带一组三芯串联的PTC热敏电阻用于跳闸 3 PTC thermistors for tripping

C = 绕组带两组三芯串联的PTC热敏电阻用于报警和跳闸 6 PTC thermistors for alarm and tripping

H = 绕组带3个Pt100测温元件 3 resistance thermometers Pt100

J = 绕组带6个Pt100测温元件 6 resistance thermometers Pt100

接线盒位置编号 (从驱动端看) Code location of connection box (view from drive end)

4 = 顶端出线 top / 5 = 右端出线 onRHS / 6 = 左端出线 onLHS

# 安装

用户须按照GB 3836.15的要求正确选型和安装，并严格按照该产品使用说明书要求使用。

## 3.1 准备安装区域

电机安装的基础可以是金属底座，也可以是混凝土平台。基础应具有足够的强度与刚度来支撑电机。常用电机支承面的平面度要求如下：

机座号	平面度 (mm)
≤ 132	0.10
160	0.15
≥ 180	0.20

安装位置应避免长时间受强烈阳光直接照射、雨雪、冰雹的侵蚀。

对于轴伸向下竖直安装的电机，应避免异物落入风扇罩；对于轴伸向上竖直安装的电机，应避免液体沿轴伸流入电机。

防爆电机只能在允许的环境中使用。

## 3.2 确保合理的冷却

---

### 警告

#### 电机过热

如果不注意以下几点，可能会造成财产损失、重伤或死亡。

- 切勿阻碍通风。
  - 防止临近机组的废气被直接吸入。
  - 对于风扇进气口朝上的竖直安装的电机，应防止异物和水从进气口进入。
  - 对于轴伸端朝上的竖直安装的电机，应防止液体沿轴流入电机。
- 

对于带有独立驱动风扇的电机，请对电路进行设计以防止在独立风扇未运行时接通电源并运行主电机。电机安装时风路的考虑见下表。

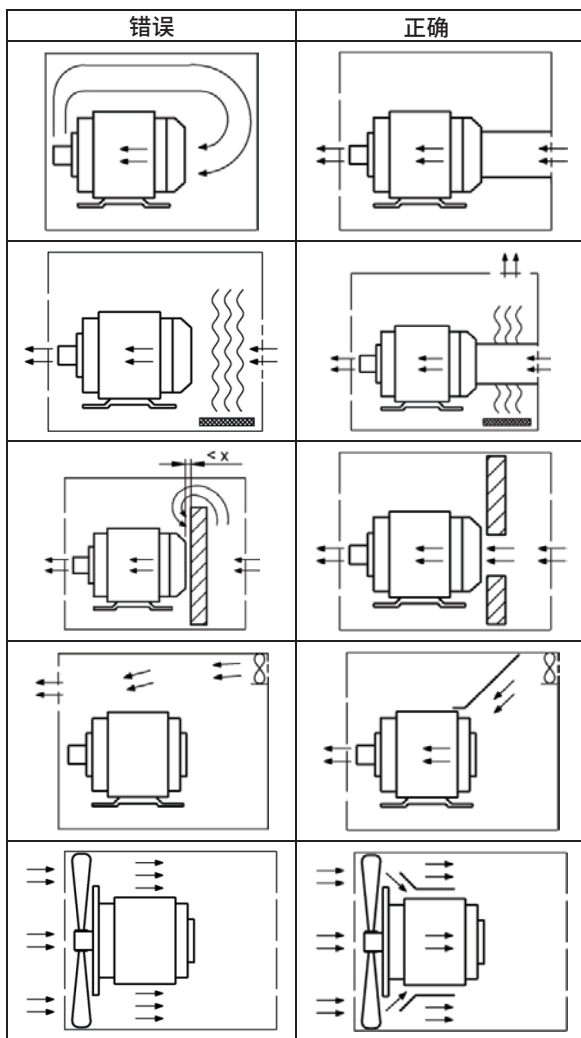

电机进风口与后方相邻障碍物的最小间距“X”尺寸见下表。

机座号	X (mm)
80-100	20
112	25
132	30
160	40
180-200	90
225-250	100
280-315	110
355	140

### 3.3 安装

对轴伸上传动件（联轴器、齿轮、皮带轮等）进行拆装时，应使用合适的工具，必要时进行热套操作。请勿使用锤子或类似工具敲击。电机轴伸上允许施加的径向载荷和轴向载荷不得超过样本上规定的最大值。

由于机械部件制造公差及累积误差的存在，电机底脚平面与安装基础的接触面之间可能存在间隙。安装时应用塞尺测量此间隙，对于 $\geq 0.05\text{mm}$ 的间隙，应插入合适的填隙片。填隙片尺寸根据实际间隙大小配做。

当安装螺栓头部与电机外圆面发生干涉时，请将电机吊离对接法兰盘面，先将螺栓穿过法兰安装孔，把螺栓拧至头部与电机不干涉，对接法兰盘，再拧紧安装螺栓。

---

#### 警告

##### 电机掉落

如果不注意以下几点，可能会造成财产损失、重伤或死亡。

- 起吊前确保吊环都已拧紧。
- 起吊时必须使用电机上所有吊环。
- 务必使用合格的吊装索具进行作业。

---

除非另行规定，通常需使用符合 GB/T3098.1（ISO898-1）中规定的强度等级至少为 8.8 的紧固件，以安全固定电机。

电机与被驱动设备间所需对中精度主要取决于整个电机传动系统的配置。对时时务必遵循联轴器制造商要求的对中精度。

电机转子是动平衡的。只能使用已钻好孔并校准过平衡的从动元件。只能使用合适的工具安装和拆卸从动元件。使用轴顶端的螺纹孔或用手推将从动元件一次性装入。不允许使用锤子敲打，否则会损坏轴承。从动件必须安装到位，在电机轴伸上必须紧靠轴肩。

---

#### 警告

##### 键可能抛出

如果不注意以下几点，可能会造成财产损失、重伤或死亡。

- 键仅在运输过程中被固定以防止脱落，如果电机在未安装从动元件时启动，则键可能会在运行期间被抛出。
  - 请固定好无从动元件的轴伸上的键，防止键被抛出。
-

## 3.4 电气连接

危险

危险电压

可能导致死亡、重伤或财产损失。

- 所有操作只能由合格的专业人员在静止的电机上进行。
- 断开电源并确保不会被意外接通，该要求同样针对辅助电路。
- 确认无电压！
- 在开始工作前进行可靠的保护线连接！
- 供电电网的电压、频率、波形等相对于额定值的偏差会导致温度升高，同时也会影响电磁兼容性。
- 通常情况下不允许运行未接地的电机。只在极少数情况下可短暂运行，例如排查故障时。

接线盒上有用于安装葛兰或闷盖的螺纹孔，螺纹孔规格和葛兰配套的外接电缆直径如下。

机座号	螺纹规格	外接电缆直径 mm
80	M25x1.5+M16x1.5	13-18
90	M25x1.5+M16x1.5	13-18
100	M32x1.5+M32x1.5	18-25
112	M32x1.5+M32x1.5	18-25
132	M32x1.5+M32x1.5	18-25
160	M40x1.5+M40x1.5	22-32
180	M40x1.5+M40x1.5	22-32
200	M50x1.5+M50x1.5	32-38
225	M50x1.5+M50x1.5	32-38
250	M63x1.5+M63x1.5	37-44
280	M63x1.5+M63x1.5	37-44
315	M63x1.5+M63x1.5	37-44
355	M72x2+M72x2	44-57

电机出厂时这些螺纹孔由符合要求的闷盖密封。必须使用具有相应防爆区域（Zone分区）和防爆等级认证的并带有相应标识的葛兰、转接头和堵头。在接线盒内进行接线时，需确保电缆与接线螺栓连接可靠。接地螺栓推荐的拧紧力矩参考下表。

接线螺栓规格		M4	M5	M6	M8	M10	M12	M16	M20
拧紧力矩 (Nm)	最小	1	1.6	2.5	5	8	13	25	42
	最大	1.2	2	3	6	10	15.5	30	52

关于电机机壳外接地螺栓和接线盒内接地螺栓规格，请参见下表。

机座号	80-132	160-180	200-315	355
接线盒内部接地螺栓规格	M5	M6	2-M6	M10
机座号	80-180	200	225-355	
机壳外部接地螺栓规格	M6	2-M6	2-M8	

注：2-M6和2-M8用两颗接地螺栓与接地板连接安装接地电缆单独的其颗接地螺栓。若电机选配了温度传感器、防潮加热带等选件，其辅助电路的连接参考下面接线端子标识的说明。

电机绕组温度保护：

一组三芯串联PTC		两组三芯串联PTC				三个单支两线制PT100						六个单支两线制PT100											
第15位为B		第15位为C				第15位为H						第15位为J											
ZTP1	ZTP2	ZTP1	ZTP2	ZTP1	ZTP2	1R1	1R2	2R1	2R2	3R1	3R2	1R1	1R2	2R1	2R2	3R1	3R2	4R1	4R2	5R1	5R2	6R1	6R2

电机轴承温度保护：

两个单支两线制PT100			
选项代码 Q72			
10R1	10R2	11R1	11R2

防潮加热带的接线端子编号为1HE1和1HE2。

注：

1. 电机绕组温度保护，PTC、PT100，建议报警温度设定为 145°C，跳闸温度设定为 155°C。

2. 轴承的报警跳闸设置

2.1 当电机的标准使用环境温度为 -20°C~+40°C，建议报警温度设定为 95°C，跳闸温度设定为 105°C。

2.2 当选项 N05、N06、N07、N08 时，电机的使用环境温度为 -20°C~+60°C。轴承温度会随着环境温度的升高而升高，建议如下。

调试前，如果电机配有轴承测温传感器，在电机首次运行前，请在监控装置上设置关机温度。

设定值	温度
报警	115 °C
关闭	120 °C

正常运行时，在考虑环境条件、轴承负载以及机器对电机影响的情况下，测量轴承的最高运行温度 T 运行，单位：°C。根据该运行温度 T 运行设置用于关机和报警的温度值。

设定值	温度
报警	$T_{\text{运行}} + 5 K \leq 115 ^\circ\text{C}$
关闭	$T_{\text{运行}} + 10 K \leq 120 ^\circ\text{C}$

3. 对于使用环境温度高于 40°C 不超过 60°C 时（选项 N05、N06、N07、N08），应选用耐温不低于 98°C 的电缆。为保证电缆和密封圈运行可靠，需根据电机额定电流选择合适的电缆，确保电缆引入装置入口和电缆分支点最高工作温度分别不超过 70°C 和 80°C。高于该温度时应考虑更换电缆，并与制造单位联系确认适用性。

注：电机轴承测温元件在电机内部。

电机出厂时接线盒上的进线孔已使用符合要求的闷盖密封，接线后未使用的进线孔应保持其密封状态。接线盒内的接地和机壳外部的接地点必须有效接地。建议用户按照 GB 3836.15 要求，选用与电机相匹配的电气保护。

## 3.5 连接后的检查

在完成接线后应检查以下几点：

- 接线盒中的电气连接已按照前面的说明完成，并以正确的力矩拧紧。
- 非绝缘组件之间的电气间隙。
- 不能有遗留的线头。
- 电机按照需要的旋转方向进行接线。
- 接线盒内必须保持整洁，不能有多余的零件和杂物。
- 所有密封件和接合面不能有损伤，且须保持干净。
- 接线盒中未使用的进线孔密封完好。
- 所有接地点都已正确接地。

# 启动

## 4.1 启动前的检查

在完成安装和连接后，在调试前请检查以下事项：

- 电机未受损。
- 电机按要求进行了安装和对中，被驱动组件已进行了正确的平衡和设置。
- 所有紧固件和电气连接件都已拧紧。
- 电机运行条件与技术文档中的规定一致，如爆炸环境类别、防护等级、环境温度等。
- 可移动部件，如联轴器，可自由转动。
- 所有活动件和带电零件都进行了安全防护。

## 4.2 试运行

在安装电机后执行一次试运行：

- ① 首先空载启动电机，检查电机旋转方向。
- ② 空载正常时，给电机连接负载。
- ③ 在试运行期间检查并记录以下数据：
  - 检查运转时的噪声和振动情况。
  - 记录电压、电流和功率值。
  - 尽量使用可用的测量设备，检查轴承和绕组的温度。
- ④ 如果电机运行不平稳或发出异响，应立即关闭电机，并在电机惯性停转过程中排查故障原因：
  - 如果断开电源后噪声或振动明显改善，则说明是电磁方面的原因。
  - 如果断开电源后没有改善，则说明是机械方面的原因。可能的原因包括电机或负载设备不平衡，机组未充分对中，电机和系统发生共振。
- ⑤ 如果电机使用独立驱动风扇，则应在试运行时检查独立风扇的转向。

# 运行和维护

## 5.1 运行中的安全提示

### 危险

---

#### 危险电压

可能导致死亡、重伤或财产损失。

电气设备带有危险电压，如果接触设备表面、端子等部位，可能存在触电危险。

### 警告

---

#### 运行期间的故障

运行过程中的异常状况表示电机可能出现了故障。这些故障可能导致财产损失、重伤或死亡。请注意以下故障征兆：

- 异常高功率消耗
  - 异常高温
  - 异常噪声
  - 异常振动
  - 异常气味
  - 监控装置发出的响应
- 

### 警告

严禁带电开盖，所有工作必须有熟练的工人进行操作，电机做任何操作工作之前，确保电机与主线及辅助电源断开。并且确保电源不被意外开启。断电后，开盖前应延迟十分钟，开盖后确保粉尘不进入电机内部。

---

### 注意

#### 电机损坏或轴承寿命缩短

- 务必要遵守允许的振动值，避免不平稳的工作环境和冲击，以避免电机或轴承损坏。
  - 务必要遵守样本上允许的轴向径向载荷。
  - 使用变频器驱动时，采取措施减小轴承电流。
- 

### 注意

#### 冷凝水引起的腐蚀危险

电机温度或环境温度的变化可能造成电机内部出现冷凝水。如果电机带有防潮加热带，请确保在关闭电机后，防潮加热带被接通。

---

### 注意

#### 电机过热

如果电机带有防潮加热带，请确保在启动电机前，防潮加热带停止工作。

---

若电机装配圆柱滚子轴承，空载运行时因无径向预紧力，轴承易发生打滑，轴承噪声大。打滑初期，会在轴承滚道及滚动体上产生明显的粘着及拖尾痕迹，建议缩短空载运行时间或增加一定的径向预紧力。

### 5.1.1 降低轴承电流

必须全面仔细的评估电机、变频器和负载机器构成的整体系统，才可以确实避免轴承电流造成的损害。

- 除通过实心保护地电缆对电机进行接地外，在高频范围内还需使用扁平铜芯编织电缆或高频绞线电缆进行低阻抗接地。需通过较大的接触面积连接这些电缆。由于集肤效应，实心铜电缆不适合用于高频接地。
- 使用对称结构的屏蔽电缆将电机接线连接在变频器上。由多根细导线组成的编织屏蔽层必须具有良好的导电性能。由铜线或铝线织成的屏蔽网较为合适。电缆屏蔽层应在电机和变频器这两端进行连接，未屏蔽的电缆头应尽可能短。



- 保持屏蔽电缆两端的平面接触面的面积较大，以确保较好的排出高频电流。电缆屏蔽层应 360° 搭接在电机外壳以及变频器的保护接地母排上，如有：
    - 电机侧：进线处使用 EMC 格兰头
    - 变频器侧：EMC 屏蔽卡圈
  - 在整个系统中安装性能良好的针对高频电流的低阻抗网状接地系统。
  - 在电机、变频器和工作机之间没有电位差。
    - 在接线盒和电机外壳上的高频接地点之间使用等电位电缆。
    - 在电机外壳和变频器的保护接地母排之间使用单独的高频等电位电缆。
    - 在电机外壳和负载机器之间使用单独的高频等电位电缆。
  - 在变频器输出端上使用共模滤波器（磁环）。Innomotics 销售伙伴负责滤波器的选型设计。
  - 使用输出滤波器来限制升压。输出滤波器可以减少输出电压中的谐波含量。
  - 安装电机电抗器。
- 变频器的使用不在本文档中说明。请一并遵循变频器选型规定。

### 5.1.2 电机在变频器上运行时采用绝缘轴承

如果您在低压转换器上运行机器，请根据机器类型在非驱动端使用绝缘轴承。

轴 高 度	非 驱 动 端 绝 缘 轴 承
180... 225	可 询 价
250 ... 355	可 选

绝缘转速编码器是选配附件。

遵循电机铭牌上有关轴承绝缘及允许的跨接的说明。

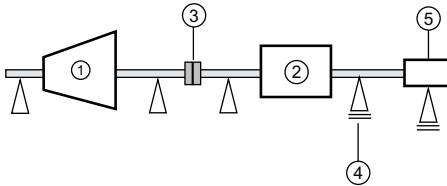

- ① 负载机械
- ② 电机
- ③ 联轴节
- ④ 绝缘轴承
- ⑤ 绝缘转速计

图 4-1 单轴驱动的示意图

#### 注意

##### 轴承损坏

不允许跨接轴承绝缘层。如有电流通过，可能会对轴承造成损坏。

- 在后续的安装作业中，如安装自动润滑系统或非绝缘性振动传感器，请勿跨接轴承绝缘层。
- 如有疑问，请联系服务中心。

如果希望串联 2 台电机，即所谓的“双轴驱动”，则需要在这两台电机之间安装绝缘联轴节。

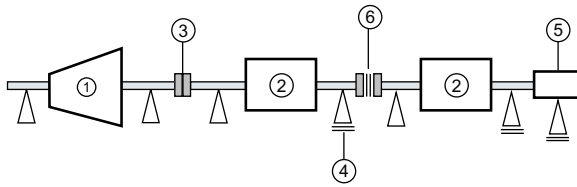

- |        |         |
|--------|---------|
| ① 负载机械 | ④ 绝缘轴承  |
| ② 电机   | ⑤ 绝缘转速计 |
| ③ 联轴节  | ⑥ 绝缘联轴节 |

图 4-2 双轴驱动的示意图

#### 注意

##### 轴承损坏

如果未在进行双轴驱动的两个电机之间使用绝缘联轴节，则可能出现轴承电流。这可能会对两个电机的驱动端轴承造成损坏。

- 请使用绝缘联轴节连接电机。

### 5.1.4 双轴驱动

如果希望串联两台电机，即所谓的“双轴驱动”，则需要在这两台电机之间安装符合指令 2014/34/EU 或所在国家适用法规的联轴节。

## 5.2 运行

请尽可能在空载时启动电机并检查运转噪声。使用可用的测量设备，检查电机运行时的温度和振动。

---

### 注意

#### 直连运行的电机出现过载

除了反作用力矩，启动时间还主要受转动惯量的影响。启动时，电机的电流会达到额定电流的数倍。这会导致电机过热，电机可能被损坏。因此启动时应注意以下几点：

- 请遵循产品样本或订货文档中涉及的极限值或启动条件。
  - 监控每次启动时间以检查是否出现异常。
- 

若电机有独立驱动风扇，在关闭电机后，请不要立即关闭独立风扇。请等待直至电机冷却后再关闭独立风扇。这可避免余热积聚。

若电机长时间停机（超过 1 个月），应每月运行一次，或至少转动转子一次。若电机停机时间超过 12 个月，请采取适当的防腐蚀、包装及干燥措施，否则电机可能因环境影响而损坏。并在再次开机前执行第 5 章中的检查和试运行。

## 5.3 检查和维护

### 危险

#### 静电可引发爆炸

可能导致死亡、重伤或财产损失。

清洁时，塑料部件可能产生静电并引燃爆炸性介质，这可能会导致爆炸。

- 确保不在爆炸性环境中进行清洁。
- 清洁非金属部件时，避免静电积聚。
- 请勿使用压缩空气进行清洁。
- 电机在正常使用、维护和清洁时应避免由静电电荷引起点燃危险，在爆炸性环境中清洁时应使用湿布擦拭。

应定期检查骨架油封、橡胶密封垫和O形密封圈是否磨损和老化（表面有龟裂、发粘、硬化、粉化等）如果磨损和老化，应及时更换密封件。

当更换密封件时需注意接线盒座密封垫、接线盒盖密封垫、端盖与机座之间ⓐ形密封圈需要用胶水点胶固定，防止脱落。

---

在新电机运行约 500 小时或最晚一年后，请进行首次检查：

- 电机是否保持规定的电气特性。
- 轴承温度是否在允许范围内。
- 电机是否运行平稳，没有发出更大噪声。
- 电机安装基座是否出现裂缝和凹陷。

根据系统本身的特殊条件，可能还要完成其它的检查项目。

建议在电机运行 16000 小时或最晚两年后，进行例行检查：

- 电机是否保持规定的电气特性。
- 轴承温度是否在允许范围内。
- 电机是否运行平稳，没有发出更大噪声。
- 电机安装基座是否出现裂缝和凹陷。
- 电机的对中是否在允许的公差范围内。
- 所有机械和电气连接的紧固件都保持拧紧状态。
- 所有等电位连接、接地连接和屏蔽层的位置都正确并正常接触。
- 绕组的绝缘电阻足够大。
- 电缆、密封件、绝缘件的情况良好且没有变色现象。

电机按照样本上所规定的最大载荷值运转时，轴承寿命至少为 20000 小时。对于不受轴向径向载荷的电机，其轴承寿命至少为 40000 小时。请务必按照电机铭牌或技术文档中规定的润滑脂型号对轴承进行润滑，加注油脂量和润滑周期参见下表。润滑脂使用温度范围符合电机应用的环境温度。加注润滑脂时应旋转电机轴以使润滑脂均匀分布。为避免添加过量润滑脂，在添加润滑脂前，应打开排油塞。添加完成后，应让电机运转一段时间，确定排油孔无润滑脂流出后再装上排油塞。

极数	机座号	持久润滑型 轴承的润滑脂	可再润滑型 轴承的润滑脂	再润滑周 期(小时)	加注油脂 量(克)
2, 4, 6	80-90	标配	-/-	-/-	-/-
2, 4, 6, 8	100-132	标配	-/-	-/-	-/-
2, 4, 6, 8	160	标配	选项 (L23)	8000 h	15g
2	180-250	标配	选项 (L23)	4000h	20g
4, 6, 8	180-250	标配	选项 (L23)	8000 h	20g
2	280	-/-	标配	3000h	30g
4, 6, 8	280	-/-	标配	5000h	30g
2	315	-/-	标配	3000h	30g
4, 6, 8, 10	315	-/-	标配	5000h	40g

使用防爆认证带“X”标记的防爆电机时，只能在遵守制造商设计说明的情况下才能维修该产品。

REACH 法规第 33 条的规定

该产品的一个或多个组成物中含有高关注物质候选清单中的以下物质超过

0.1%：• CAS 编号 7439-92-1，铅

基于现有信息，在规范化使用的条件下，包括废弃处理，该物质不会产生风险。未经茵梦达授权，禁止擅自改装电机，否则保修将无效。

## 5.4 密封结构图

粉尘防爆电机密封结构如下：

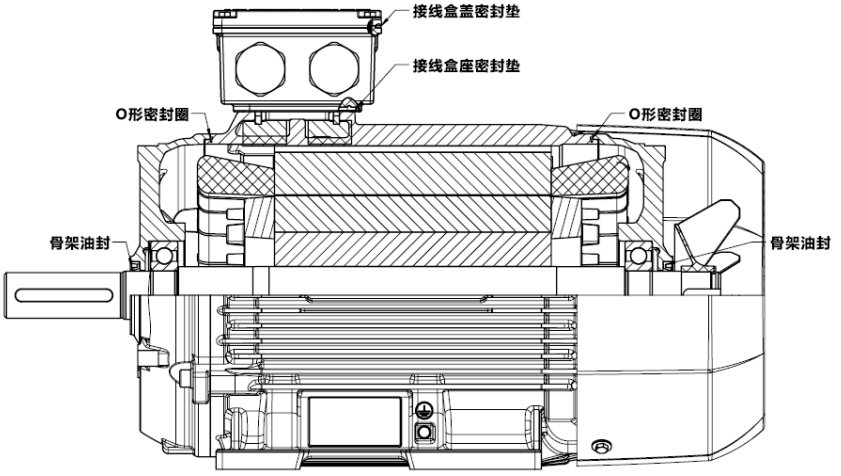

## 废弃物处理

茵梦达一直将保护环境和节约资源视为企业的首要目标。在全球范围内我们采用了符合 ISO 14000 的高标准环境管理措施，它符合目前的环保法律法规。从开始设计产品时我们便十分注重设计的环境安全、技术安全和人身安全。

下面我们为您推荐如何以环保的方式处理电机及其组件的废弃物。请遵循当地关于废弃物处理的规定。

### 当地法律法规



电机包含可循环或再利用的材料。正确地分割材料有助于方便地对重要材料进行再利用。

### 6.1 RoHS - 特定危险材料的使用限制

根据 RoHS（“Restriction of certain Hazardous Substances”），我们利用最新技术将环境有害材料更换为无害材料。我们始终将电机运行和操作中的安全性放在首位。

### 6.2 REACH 法规第 33 条的规定

该产品的一个或多个组成物中含有高关注物质候选清单中的以下物质超过 0.1%：

- CAS 编号 7439-92-1，铅

基于现有信息，在规范化使用的条件下，包括废弃处理，该物质不会产生风险。

## 6.3 拆卸的准备工作

必须由具备专业知识的合格人员拆卸电机或监管电机的拆卸。

1. 请联系您附近的废弃物专业处理公司，告知对电机或组件拆卸质量的要求。
2. 遵守五项安全规程。
3. 断开所有的电气连接并拆除所有电缆。
4. 清空所有的液体，如油、冷却液等。单独收集各种液体并进行专业处理。
5. 松开电机的固定装置。
6. 将电机搬运到适合拆卸的位置。

## 6.4 拆解电机

按照一般的机械装置拆解步骤拆解电机。

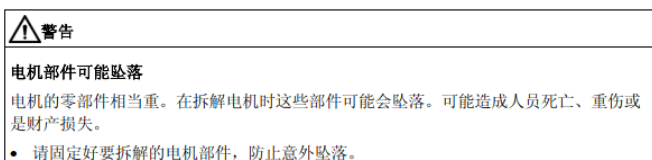

## 6.5 处理组件的废弃物

组件

电机主要由钢制材料构成，部分是铜制和铝制材料。金属材料通常是可循环利用的材料。根据以下类别对组件进行分类，以便循环利用：

- 钢铁
- 铝
- 有色金属，如绕组在回收铜时绕组绝缘层会被灰化。
- 绝缘材料
- 电线和电缆
- 电子废品

## **辅助材料和化学材料**

废弃物处理时，按照以下类别区分辅助材料和化学材料：

- 油
- 油脂
- 清洁剂和溶剂
- 油漆残渣
- 防腐剂
- 冷却液添加剂如防蚀剂，防锈剂或杀虫剂

请按照当地的规定处理分离出的组件或交给废弃物回收企业进行处理。该要求也同样适用于清洗电机的抹布和清洁材料。

## **包装材料**

- 如有需要，请联系废弃物回收企业。
- 海运的木材包装由经过浸渍的木材构成。请遵照当地的相关规定。
- 密封包装的薄膜是铝复合膜。它可以加热再利用。

被污染的薄膜必须作为废弃物烧掉。

# Content

<b>1 Safety information</b> .....	<b>25</b>
1.1 The five safety rules .....	25
1.2 Qualified personnel .....	25
1.3 Electromagnetic fields when operating electric machines .....	25
1.4 Operating in hazardous area .....	26
<b>2 Preparation before using</b> .....	<b>27</b>
2.1 Application scope .....	27
2.2 Cooling method .....	27
2.3 Mounting and construction type .....	27
2.4 Delivery and storage .....	27
2.5 Model naming explanation and specification code description.....	30
<b>3 Installation</b> .....	<b>31</b>
3.1 Preparing installation place .....	31
3.2 Ensure adequate cooling .....	31
3.3 Installing .....	33
3.4 Electric connection .....	34
3.5 Checking after connection .....	36
<b>4 Start-up</b> .....	<b>37</b>
4.1 Checking before start-up .....	37
4.2 Test run .....	37
<b>5 Operation and maintenance</b> .....	<b>38</b>
5.1 Safety information during operation .....	38
5.2 Operation .....	43
5.3 Inspection and maintenance .....	44
5.4 Sealing structure diagram .....	46

# Safety information

## 1.1 The five safety rules

For personal safety and to prevent damage, when carrying out any work, please always observe and obey safety instructions and the following five safety rules according to EN50110-1 "Working at voltage-free status". Apply the five safety rules in the sequence stated.

- ① Disconnect the system, including auxiliary circuits, for example, anti-condensation heaters.
- ② Make sure circuits not being re-connected coincidentally.
- ③ Verify no voltage on equipment.
- ④ Connect grounding and short-circuit.
- ⑤ Cover or isolate adjacent live parts.

Energize the system by recover the measures in reverse order.

## 1.2 Qualified personnel

All work on the machine must only be carried out by qualified personnel. For the purpose of this document, qualified personnel mean people who fulfill following requirements:

- Through appropriate training and experience, be able to recognize and avoid risks and potential dangers in responsibility.
- Must be appointed by responsible person.

## 1.3 Electromagnetic fields when operating electric machines

Electronic devices may be interfered by electric machines. Electromagnetic fields will be generated during electric machines' operating. Potentially lethal malfunctions can occur on medical implants, e.g. pacemakers, in the surrounding area of electric machines. Data may be lost in magnetic or digital data carriers.

- It is forbidden for people with pacemakers to stay nearby the machine.
  - Take proper measures to protect personnel working in the plant. For example, making signs, safety barriers, setting safety instructions and markings.
  - Obey safety and labor protection laws and regulations.
  - Do not put magnetic and digital data media near electric machines.
- This motor fulfills standard GB/T755 (IEC/EN60034-1). When used as prescribed, it complies with electromagnetic compatibility requirements.

## 1.4 Operating in hazardous area

Electric machines in hazardous area must be installed, commissioned, and operated only by qualified personnel, and must follow valid regulations.

---

### Note

Requirements of electric machines and operation in hazardous area can refer to standard GB3836.

---

Users shall consult with local supervisor departments for evaluating area conditions and equipment risks, and to define necessary monitoring and control methods. These methods shall be organized as regulations and must be obeyed at any condition. Because of the variability of local conditions, motor manufacturer cannot provide universally applicable advices.

---

### Note

Assessment of electric machines and hazardous areas can refer to series standard GB3836.

---

For motors with third-party certifications, certified technical specifications and special conditions are fulfilled. Certification documents shall be observed.

For Ex motors with marking "X" in certification number, repairing can only be taken according to manufacturers' instructions.

# Preparation before using

# 2

## 2.1 Application scope

1MT8014 series enclosure flameproof motor's designing and manufacturing fulfills standards GB/T3836.1-2021 "Explosive atmospheres - Part 1: Equipment -General requirement " and GB/T3836.31-2021 "Explosive atmospheres -Part 31: Equipment dust ignition protection by enclosure "t". Explosion mark is Ex tb IIIC T130°C Db. Applicable to work in dust explosive areas Zone 21 and Zone 22. This series of motor fulfills energy level grade 2 of GB18613 "Minimum allowable values of energy efficiency and energy efficiency grades for small and medium three-phase asynchronous motors" (IE4 in IEC/ EN60034-30). For energy efficiency of specific motor type, please refer to nameplate. Motor's working condition is altitude within 1000m, ambient temperature -20°C ~ +40°C. The working environment of the motor is not more than 1000 meters above sea level, and the ambient temperature ranges from -20°C to +40°C. The ambient temperature ranges from -40°C to +40°C for the D03 option and -20°C to +60°C for the N05, N06, N07 and N08 options. Continuous duty S1. When the product uses an purchased cable introduction device, it should be compatible with the overall operating environment of the machine and obtain explosion-proof certification.

Voltage frequency:

220V/380V 50Hz, 230V/400V 50Hz, 240V/415V 50Hz, 380V/660V 50Hz, 400V/690V 50Hz, 220V 50Hz, 230V 50Hz, 380V 50Hz, 400V 50Hz, 415V 50Hz, 440V 50Hz, 460V 50Hz, 480V 50Hz, 500V 50Hz, 575V 50Hz, 660V 50Hz, 690V 50Hz, 220V/380V 60Hz, 230V/400V 60Hz, 380V/660V 60Hz, 400V/690V 60Hz, 220V 60Hz, 230V 60Hz, 380V 60Hz, 400V 60Hz, 415V 60Hz, 440V 60Hz, 460V 60Hz, 480V 60Hz, 500V 60Hz, 575V 60Hz, 660V 60Hz, 690V 60Hz Case protection class: IP65

Motor profile:

1MT8014-1AA4, 1MT8014-1AB4, 1MT8014-1AB5, 1MT8014-1AC4, 1MT8014-1BA2, 1MT8014-1BB2, 1MT8014-1BC2, 1MT8014-1CA0, 1MT8014-1CA1, 1MT8014-1CB0, 1MT8014-1CB2, 1MT8014-1CC0, 1MT8014-1CC2, 1MT8014-1CC3, 1MT8014-1CDO, 1MT8014-1CD2, 1MT8014-1DA2, 1MT8014-1DA3, 1MT8014-1DA4, 1MT8014-1DB2, 1MT8014-1DB4, 1MT8014-1DC2, 1MT8014-1DC4, 1MT8014-1DD2, 1MT8014-1DD3, 1MT8014-1DD4, 1MT8014-1EA2, 1MT8014-1EB2, 1MT8014-1EB4, 1MT8014-1EC4, 1MT8014-1ED4, 1MT8014-2AA4, 1MT8014-2AA5, 1MT8014-2AB5, 1MT8014-2AC4, 1MT8014-2AC5, 1MT8014-2AD5, 1MT8014-2BA2, 1MT8014-2BB0, 1MT8014-2BB2, 1MT8014-2BC2, 1MT8014-2BD0, 1MT8014-2BD2, 1MT8014-2CA2, 1MT8014-2CB2, 1MT8014-2CC2, 1MT8014-2CD2, 1MT8014-2DA0, 1MT8014-2DA2, 1MT8014-2DB0, 1MT8014-2DB2, 1MT8014-2DC0, 1MT8014-2DC2, 1MT8014-2DD0, 1MT8014-2DD2, 1MT8014-3AA0, 1MT8014-3AA2, 1MT8014-3AA5, 1MT8014-3AA6, 1MT8014-3AA7, 1MT8014-3AB0, 1MT8014-3AB2, 1MT8014-3AB5, 1MT8014-3AB6, 1MT8014-3AB7, 1MT8014-3AC0, 1MT8014-3AC2, 1MT8014-3AC5, 1MT8014-3AC6, 1MT8014-3AD0, 1MT8014-3AD2, 1MT8014-3AD5, 1MT8014-3AD6, 1MT8014-3BA2, 1MT8014-3BA3, 1MT8014-3BA5, 1MT8014-3BA6, 1MT8014-3BB2, 1MT8014-3BB3, 1MT8014-3BB5, 1MT8014-3BB6, 1MT8014-3BC2, 1MT8014-3BC3, 1MT8014-3BC4, 1MT8014-3BC5, 1MT8014-3BC6, 1MT8014-3BD2, 1MT8014-3BD3, 1MT8014-3BD5, 1MT8014-3BD6

## 2.2 Cooling method

The standard cooling method is self-ventilation with fan according to IC411 in GB1993 (IEC/EN60034-6).

If use separately driven fan, cooling method code IC416, please design the circuit so as the motor cannot start-up when the separate fan is not running.

## 2.3 Mounting and construction type

Motor's mounting and construction type fulfills the standard GB/T997 "Rotating electrical machines - Classification of types of construction and mounting arrangements (IM Code)" (IEC/EN60034-7). It is stamped on motor's nameplate.

## 2.4 Delivery and storage

Check cargo's completeness immediately when receiving.

- Report any transportation damage to delivery agent immediately.
- Report any defect/missing to Innomotics office immediately.

---

#### Note

##### Motor damage

Motor may be damaged if incorrectly stored.

Protection methods should be taken under critical climate conditions.

---

Storage place should be horizontal, stable, and dry. Put the motor on pallet, wood block, or foundation to prevent moisture. Avoid sinking into ground. Covers or tarpaulins used to protect against weather must not contact machine's surface.

Avoid influence from critical climate. Storage place should be dry, well-ventilated, and avoid dust, frozen, impact, or severe vibration.

When store for a long period ( $\geq 6$  month), anti-corrosion methods must be taken to bare metal.

---

#### Warning

Explosion may occur if sealing material damaged

If motor is stored at exceeded temperature, sealing materials may be damaged due to temperature. Explosive gas and dust may leak into the motor and result to explosion. This may cause damage, serious injury, or death.

---

Conditions for storage:

Allowed ambient temperature:  $-20^{\circ}\text{C} \sim +50^{\circ}\text{C}$

Allowed relative humidity: 60%

If the motor has special design for special ambient temperature, humidity, or altitude, its storage conditions may be different. In this case, please refer to the environment conditions on nameplate.

Period for storage:

Motor shaft shall be turned at least once a month to avoid brinelling. Long-term storage will shorten bearing grease lifetime. For the motor with closedtype bearings, after two years storage, bearings should be replaces before using; for the motor with open-type bearings, after two years storage, new grease should be added before using. Bearing grease type, re-greasing

quantity, and intervals can refer to nameplate.

## 2.5 Model naming explanation and specification code description

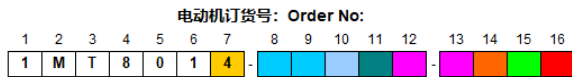

电机系列 Motor series

1MB801 - 茵梦达粉尘防爆电机, Innomotics Dust explosion proof motors

1MT801 - 贝得粉尘防爆电机, Beide Dust explosion proof motors

能效等级 Efficiency grade

4 = IE4, 中国能效等级2级 China Energy Efficiency Grade 2

机座号编号 Code of frame size

0D = 080 / 0E = 090

1A = 100 / 1B = 112 / 1C = 132 / 1D = 160 / 1E = 180

2A = 200 / 2B = 225 / 2C = 250 / 2D = 280

3A = 315 / 3B = 355

极数编号 Code of poles

A = 2 / B = 4 / C = 6 / D = 8

机座长度编号 Code of frame length

0 or 1 = S (短机座Short) / 2 or 3 or 4 = M (中机座Medium) / 4 or 5 or 6 or 7 = L (长机座Long)

电压, 连接方式和频率编号 Code of voltage, connections and frequency

**22** = 230VD/400VY 50Hz      **35** = 415VD 50Hz

**21** = 220VD/380VY 50Hz      **23** = 240VD/415VY 50Hz      **90** = 特殊电压与频率 special voltage & frequency

**33** = 380VD/660VY 50Hz      **34** = 400VD/690VY 50Hz

结构和安装方式编号 Code of construction and mounting type

A = IM B3    J = IM B35

T = IM B6

V = IM B8

N = IM B34

W = IM V15

G = IM V1

M = IM V18

F = IM B5    K = IM B14

U = IM B7

C = IM V5

D = IM V6

Y = IM V35

H = IM V3

L = IM V19

绕组保护编号 Code of winding protection

A = 无绕组保护 without winding protection

B = 绕组带一组三芯串联的PTC热敏电阻用于跳闸 3 PTC thermistors for tripping

C = 绕组带两组三芯串联的PTC热敏电阻用于报警和跳闸 6 PTC thermistors for alarm and tripping

H = 绕组带3个Pt100测温元件 3 resistance thermometers Pt100

J = 绕组带6个Pt100测温元件 6 resistance thermometers Pt100

接线盒位置编号 (从驱动端看) Code location of connection box (view from drive end)

4 = 顶端出线 top / 5 = 右端出线 onRHS / 6 = 左端出线 onLHS

# Installation

The user shall correctly select and install the product according to the requirements of GB 3836.15, and use the product in strict accordance with the instructions.

## 3.1 Preparing installation place

The motor can be installed on the foundation of metal or concrete base. The foundation should have sufficient stiffness and strength to support the motor. General flatness for motor installation foundation:

Frame size	Flatness (mm)
≤ 132	0.10
160	0.15
≥ 180	0.20

The motor installation location should avoid exposing to long-time direct sunlight, rain, snow and ice.

For the motor installed vertically with drive end downward, should take protection measures to prevent objects falling into fan; for the motor installed vertically with drive end upward, should prevent liquid flowing along the shaft. Ex motors must only be used in allowed environment.

## 3.2 Ensure adequate cooling

---

### Warning

#### Motor overheating

Pay attention to following points, otherwise damage, serious injury, or death may occur.

- Do not block ventilation.
  - Prevent the air expelled by nearby equipment from being immediately sucked in.
  - For vertically installed machines with air entry upward, prevent foreign objects and water falling into openings.
  - For vertically installed machines with shaft extension upward, prevent liquid from flowing into motor along the shaft.
- 

For motors equipped with separately driven fans, please design the power circuit so as the motor cannot start-up when the separately driven fan is not running. Considering the air flow, please refer to following table when installing motors.

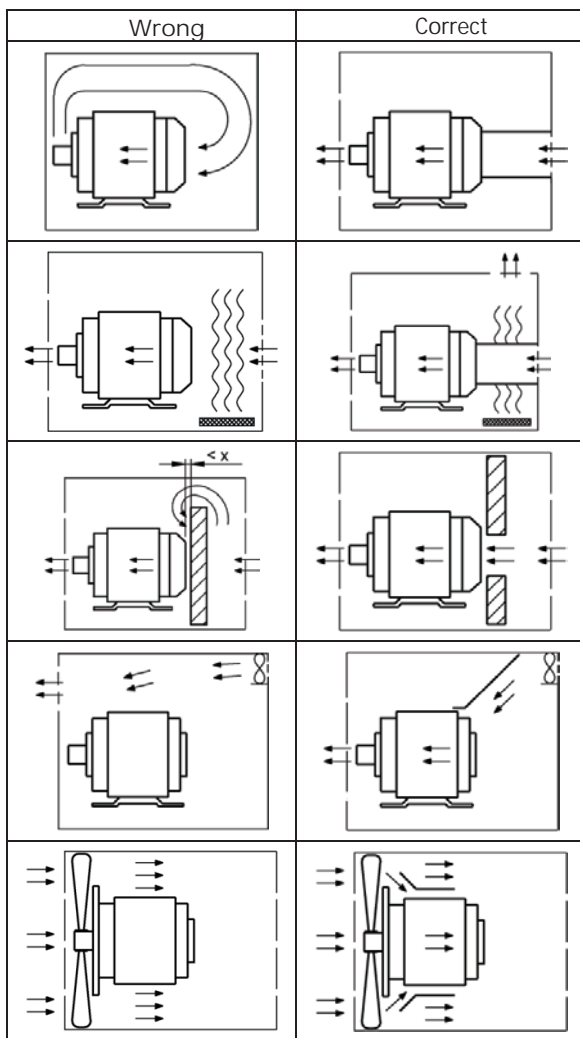

The minimum distance "X" between motor fan cover and object behind is in table below.

Frame size	X (mm)
80-100	20
112	25
132	30
160	40
180-200	90
225-250	100
280-315	110
355	140

## 3.3 Installing

When assembling or dis-assembling transmission elements (like coupling, gear, or pulley), proper tools shall be used. Use heating assembly if necessary. Do not hit with hammers. The axial and radial loads applied on shaft extension must not exceed the maximum allowed values in catalogue. Because of machining and assembly tolerances, there may be gap between motor feet and installation foundation. Please measure this gap, if it is over 0.05mm, please insert filling plates. The size of plates is determined according to the size of gap.

When the installation bolt head interferes with the outer surface of the motor, please lift the motor away from the mating flange surface. First, the bolt through the flange installation hole, tighten the bolt to a position where the head does not interfere with the motor, connect the flange, and then tighten the installation bolt.

---

### Warning

#### Motor falling

Damage, serious injury, or death may occur if motor falls.

- Check whether all eyebolts are tightened before lifting.
- Must use all eyebolts on the motor for lifting.
- Must use qualified hoisting tools and ropes for lifting.

---

If not specified, usually fasteners at least grade 8.8 according to GB/T3098.1 (ISO898-1) shall be used to fix and secure the motor.

The accuracy of alignment between motor and driven machine depends on the whole transmission system. The accuracy required by coupling manufacturer must be fulfilled.

Motor's rotor is dynamically balanced. Only finished machined and balanced driven element is allowed to use. Must use proper tools to assemble and dis-assemble the transmission element. The driven element should be assembled by using the thread hole on shaft end or by hand in one time. Do not use hammer, otherwise bearings may be damaged. Transmission element must be installed at the right position; it must be installed on shaft extension and closely contact with shaft shoulder.

---

### Warning

#### Key throwing-out

Damage, serious injury, or death may occur if key thrown-out

- The key is only secured during transportation. If the motor start-up without transmission element, the key may be thrown out during rotating.
- Please take measures to fix and secure the key on motor shaft if driven element is not assembled. Thus to prevent the key from throwing out.

### 3.4 Electric connection

---

#### Danger

Dangerous voltage

Damage, serious injury, or death may occur.

- All connection can only be made by qualified professional personnel on static motor.
- Disconnect power source and make sure it cannot be re-connected coincidentally, including auxiliary circuits.
- Verify no voltage on the motor!
- Make reliable protection connection before working!
- Deviations between actual values and rated voltage, frequency, and phase can result to temperature rising. Meanwhile influent electromagnetic compatibility.
- Normally it is forbidden to operate non-grounded motor. Only in very rarely situations can be operated for very short time, for example when doing fault checking.

---

There are threaded holes on the junction box for installing the gland or cover, and the specifications of the threaded holes and the diameter of the external cable matched with the gland are as follows.

Frame Size	Thread	Cable Diameter (mm)
80	M25x1.5+M16x1.5	13-18
90	M25x1.5+M16x1.5	13-18
100	M32x1.5+M32x1.5	18-25
112	M32x1.5+M32x1.5	18-25
132	M32x1.5+M32x1.5	18-25
160	M40x1.5+M40x1.5	22-32
180	M40x1.5+M40x1.5	22-32
200	M50x1.5+M50x1.5	32-38
225	M50x1.5+M50x1.5	32-38
250	M63x1.5+M63x1.5	37-44
280	M63x1.5+M63x1.5	37-44
315	M63x1.5+M63x1.5	37-44
355	M72x2+M72x2	44-57

These threaded holes are sealed by a conforming cap when the motor is delivered. Glans, adapters and plugs must be used with the appropriate explosion-proof Zone (Zone) and explosion-proof class certification and bearing the appropriate identification. When connecting cables in a junction box, ensure that cables are securely connected to connection bolts. The following table describes the recommended tightening torques for ground bolts.

Terminal bolt size		M4	M5	M6	M8	M10	M12	M16	M20
Torque (Nm)	Min.	1	1.6	2.5	5	8	13	25	42
	Max.	1.2	2	3	6	10	15.5	30	52

Refer to the following table for specifications of the external ground bolts of the motor housing and the ground bolts in the junction box.

Frame Size	80-132	160-180	200-315	355
Specifications of the internal groundingbolts of the junction box	M5	M6	2-M6	M10
Frame Size	80-180	200	225-355	
Specifications of shell external groundingbolts	M6	2-M6	2-M8	

Note: 2-M6 and 2-M8 use two ground bolts to install the ground cable with the ground floor, the other is a separate ground bolt.

If the motor is equipped with optional components such as temperature sensor and moisture-proof heating belt, connect the auxiliary circuit by referring to the following connector labels.

Motor winding temperature protection:

1 tri-wire PTC		2 tri-wire PTC			3 bi-wire single-lead PT100						6 bi-wire single-lead PT100												
15 <sup>th</sup> digit is B		15 <sup>th</sup> digit is C			15 <sup>th</sup> digit is H						15 <sup>th</sup> digit is J												
2TP1	2TP2	2TP1	2TP2	2TP1	2TP2	1R1	1R2	2R1	2R2	3R1	3R2	1R1	1R2	2R1	2R2	3R1	3R2	4R1	4R2	5R1	5R2	6R1	6R2

Motor bearing temperature protection:

2 bi-wire single-lead PT100			
Option code Q72			
10R1	10R2	11R1	11R2

The connection terminal for anti-condensation heater is 1HE1 and 1HE2. Note:

- Motor winding temperature protection, PTC, PT100, the recommended alarm temperature is set to 145°C, trip temperature is set to 155°C.
- Alarm trip setting of bearing
  - When the standard operating ambient temperature of the motor is -20 °C - +40 °C, it is recommended to set the alarm temperature to 95 °C and the trip temperature to 105 °C.
  - When N05, N06, N07 and N08 are selected, the ambient temperature of the motor is -20°C-+60°C. Bearing temperature will increase with the increase of the ambient temperature, the recommendations are as follows. Before commissioning, if the motor is equipped with a bearing temperature sensor, set the shutdown temperature on the monitoring device before the first operation of the motor.

Set value	Temperature
Alarm	115 °C
Shutting down	120 °C

When normal operation, Determine the maximum operating temperature of the bearings  $T_{\text{operation}}$  taking into account the temperature, bearing load and influences of the plant on the motor in °C. Set the values for shutdown and warning corresponding to the operating temperature

Top.

Set value	Temperature
Alarm	$T_{\text{operation}} + 5 \text{ K} \leq 115 \text{ °C}$
Shutting down	$T_{\text{operation}} + 10 \text{ K} \leq 120 \text{ °C}$

3. When the ambient temperature is higher than 40 °C but not more than 60 °C (options N05, N06, N07, N08), the cable with a temperature resistance of not less than 98 °C should be selected. To ensure the reliable operation of cables and sealing rings, select appropriate cables according to the rated motor current, and ensure that the maximum operating temperatures at the inlet of the cable entry device and at the branch point of the cable do not exceed 70 °C and 80 °C respectively. Above this temperature should consider replacing the cable, and contact the manufacturing unit to confirm suitability.

Note: The motor bearing temperature measuring element is inside the motor. When delivered, the thread holes on terminal box are sealed with qualified plugs. After connection, unused holes shall remain sealed. Grounding points inside terminal box and on frame outside surface must be reliable grounded.

The motor shall be equipped with electrical protection matching the motor according to the requirements of GB 3836.15.

### 3.5 Checking after connection

Check following items after connection:

- Electric connection is completed according to previous instruction and tightened with proper torque.
- Electric clearance between non-insulated parts.
- No remaining wires.
- Connection is made so as the motor will rotate on correct direction.
- Keep terminal box inside clean, no foreign parts or objects remain.
- All sealing parts and joint surfaces must keep clean, and without damage.
- Unused cable entries must keep sealed.
- All grounding points are well connected.

# Start-up

## 4.1 Checking before start-up

After installation and connection, check following items before commissioning:

- Motor is not damaged.
- Motor is installed and aligned as needed; driven elements are correctly balanced and assembled.
- All fasteners and connection parts are tightened.
- Motor's working conditions are allowed according to requirements, for example hazardous area category, IP protection level, ambient temperature.
- Moving parts, like couplings, can rotate freely.
- All active parts and live parts are protected.

## 4.2 Test run

Carry out a test run after installation:

- ① Start up the motor without load; check rotation direction.
- ② If motor runs normally, then connect load.
- ③ Check and record following data:
  - Check noise and vibration during motor running.
  - Record voltage, current, and power.
  - Use available equipment to measure temperature in bearings and windings.
- ④ If motor runs unstably or makes abnormal noise, switch off immediately.  
And try to determine the problem during motor's slowing down:
  - If noise or vibration obviously becomes better, the problem could be of electromagnetic issues.
  - If noise or vibration does not change, the problem could be of mechanical issues. Possible causes include unbalance, misalignment, and resonance.
- ⑤ If the motor is equipped with separately driven fan, this separately fan rotation direction should be checked during test run.

# Operation and maintenance

# 5

## 5.1 Safety information during operation

---

### Danger

#### Dangerous voltage

Damage, serious injury, or death may occur

Electric machines have dangerous voltage, if contact machine surface, terminals, or other positions, dangers may occur.

---

### Warning

#### Malfunctions during operation

Abnormal situation indicates that there may be malfunctions on the motor. These may cause damage, serious injury, or death. Please take care of following situations:

- Higher power consumption than usual
  - Higher temperature than usual
  - Abnormal noise
  - Abnormal vibration
  - Abnormal smells
  - Response from monitoring devices
- 

### Note

#### Motor damage or short bearing lifetime

- Please absolutely maintain the permissible vibration, avoid unstable environment or impact. Thus to prevent bearings from damage.
  - Do not exceed the permissible axial and radial load values in catalogue.
  - When powered by converter, take measures to reduce bearing current.
-

---

Note

Corrosion risks resulting from condensation

The changing of motor temperature or ambient temperature may cause condensation inside the motor. If the motor is equipped with anti-condensation heater, please make sure the heater is powered on when the motor is switched off.

---

Note

Motor over-heating

If the motor is equipped with anti-condensation heater, please make sure the heater is switched off before starting the motor.

---

If the motor is equipped with cylindrical roller bearings, during no-load operation the bearing easy to slip and the bearing noise is large. In the early stage of skidding, there may be obvious adhesion and trailing marks on the bearing raceway, so it is recommended to shorten the no-load running time or increase the radial preload force.

### 5.1.1 Reducing bearing currents

A thorough and careful evaluation of the overall system of motors, frequency converters and load machines is necessary to ensure that damage caused by bearing currents can be avoided.

- In addition to grounding the motor through a solid protected ground cable, flat copper core braided cable or high frequency stranded cable should be used for low impedance grounding in the high frequency range. These cables need to be connected through a large contact area. Due to skin effect, solid copper cable is not suitable for high-frequency grounding.
- The motor wiring is connected to the converter using a symmetrical shielded cable. The braided shielding layer composed of many thin wires must have good electrical conductivity. A shielding net made of copper or aluminum wire is more suitable. The cable shield layer should be connected at both ends of the motor and frequency converter, and the unshielded cable head should be as short as possible.

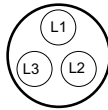

Concentric copper or aluminum

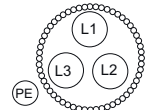
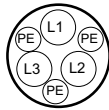

shield Steel armor

- Keep the area of the plane contact surface at both ends of the shielded cable large to ensure better discharge of high-frequency current. The cable shield layer should be 360° bonded to the motor housing and the protective ground busbar of the converter, if any:
    - Motor side: EMC grounds at the cable entries
    - Converter side: EMC shield ring
  - In the overall system, set up a properly meshed grounding system with low impedance for high frequency currents.
  - There is no potential difference among motor, converter and driven machine.
    - Use equipotential bonding conductors between the terminal box and the RF grounding point at the motor enclosure.
    - Use separate high-frequency equipotential bonding conductors between the motor enclosure and protective ground busbar of the converter.
    - Use separate high-frequency equipotential bonding conductors between the motor enclosure and the driven machine.
  - Use the common-mode filter (magnet ring) at the converter output. The Innomatics sales representative is responsible for selection and dimensioning.
  - Limit the rise in voltage by using output filters. Output filters dampen the harmonic content in the output voltage.
  - Install electric reactor for motor.
- The operating instructions for the converter are not part of this documentation. Refer to the configuration information for the converter.

### 5.1.2 Insulated bearings for converter operation

If the motor is controlled from a low-voltage converter, depending on the motor type, an insulated bearing can be fitted at the NDE.

Shaft height	NDE insulated bearing
180 ... 225	Available for inquiry
250 ... 355	Optional

The insulated speed encoder is an optional accessory.

Please follow the instructions on the motor nameplate regarding bearing insulation and permitted jumper.

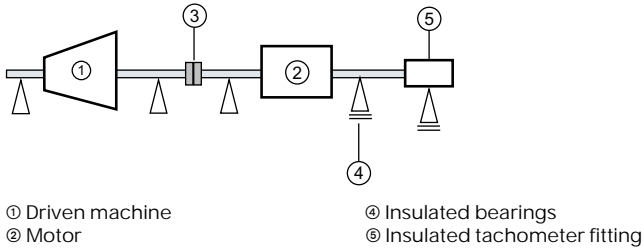

Figure 4-1 Schematic representation of a single drive

Notice
<p><b>Bearing damage</b>                      Straddle bearing insulation is not allowed. If there is current through, it may cause damage to the bearing.</p> <ul style="list-style-type: none"> <li>• Do not bridge the bearing insulation for subsequent installation work, such as the installation of an automatic lubrication system or a non-insulated vibration sensor.</li> <li>• Where necessary, contact the Service Center. (Page 12)</li> </ul>

If you connect two motors in series in "tandem operation", install an insulated coupling between the motors.



## 5.2 Operation

If possible, please start the motor without load and check noise. Use available equipment to check motor's temperature and vibration.

---

### Note

Overload of motor direct-on-line

In addition to the load torque, motor's starting time is also influenced by moment inertial. When starting up, the current can be several times of rated current. This can result to over-heating and damage. So please take care of following items when starting up:

- Please comply with the limit values and conditions defined in catalogue and technical documents.
  - Monitor the ramp-up time every time to check whether abnormal issue happens.
- 

If the motor is equipped with separately driven fan, do not switch off this fan immediately when motor is powered off. Please wait for the motor to cool down. This can prevent the accumulation of residual heat.

For long-time stoppage (over 1 month), run the machine once a month, or at least turn the rotor.

If the motor is stopped for over 12 month, please take proper measures of anti-corrosion, package, and drying; thus to prevent the motor from damage. Before starting again, please go through the checking and test run steps in Chapter 5.

## 5.3 Inspection and maintenance

---

### Danger

Explosion hazards from static-electricity

Damage, serious injury, or death may occur.

When cleaning, non-metal parts may generate static-electricity and ignite explosive substances. This may cause explosion.

- Do not execute cleaning in explosive atmosphere.
  - Avoid static accumulation when cleaning non-metal parts.
  - Do not use compressed air for cleaning.
  - The motor shall avoid the ignition hazard caused by electrostatic charge during normal use, maintenance and cleaning, and shall be wiped with a damp cloth when cleaning in an explosive environment.
- 

After new motor's 500-hour-operation or 1-year-after-installation, please make the first time inspection:

- Whether rated electrical characteristics still remain.
- Whether bearings' temperature is still in permissible scope.
- Whether motor runs steady and smoothly.
- Whether there is crevice or deform of installation foundation.

According to the system, other items may also need to check. After every 16000-hour-operation or 2-years-after-inspection, please make the following regular inspection:

- Whether rated electrical characteristics still remain.
- Whether bearings' temperature is still in permissible scope.
- Whether motor runs steady and smoothly.
- Whether there is crevice or deform of installation foundation.
- Whether alignment is still in valid tolerance.
- Whether all fasteners and connections are tightened.
- Whether all equipotential, grounding, and shield connections are connected and in contact.
- Whether the winding's insulation resistance is enough.
- Whether cables, sealing and insulations are in good status, without discoloring.

When the motor is operated according to the maximum load value specified on the sample, the bearing life is at least 20,000 hours. For motors that are not subject to axial radial loads, the bearing life is at least 40000 hours. Please be sure to lubricate the bearing according to the grease type specified in the

motor nameplate or technical documentation. The amount of grease and lubrication period are shown in the following table. The temperature range of the grease is consistent with the ambient temperature of the motor application. When adding grease, the motor shaft should be rotated to evenly distribute the grease. To avoid adding excessive grease, open the drain plug before adding grease. After the addition is completed, the motor should be allowed to run for a period of time, and the oil drain plug should be installed after the oil drain hole is free of grease.

Number of Poles	Frame Size	Permanent lubrication	Re-greasing	RE-greasing Interval(h)	Re-greasing quantity(g)
2, 4, 6	80-90	Standard	-/-	-/-	-/-
2, 4, 6, 8	100-132	Standard	-/-	-/-	-/-
2, 4, 6, 8	160	Standard	Option (L23)	8000 h	15 g
2	180-250	Standard	Option(L23)	4000h	20g
4, 6, 8	180-250	Standard	Option (L23)	8000h	20g
2	280	-/-	Standard	3000h	30g
4, 6, 8	280	-/-	Standard	5000 h	30g
2	315	-/-	Standard	3000h	30g
4, 6, 8, 10	315	-/-	Standard	5000h	40g

For Ex motors with marking "X" in certification number, repairing can only be taken according to manufacturers' instructions.

Information according to Article 33 of the REACH regulation

This product contains one or several subproducts in which the following substance – belonging to the "list of restrictions" – exists in a concentration exceeding 0.1 percent by weight.

- CAS No. 7439-92-1, lead

Based on currently available information, this substance does not represent any risk when correctly used, including its disposal.

Unauthorized changes or modifications to the motor are forbidden and will break the warranty.

## 5.4 Sealing structure diagram

The structure diagram of motor dust is as below

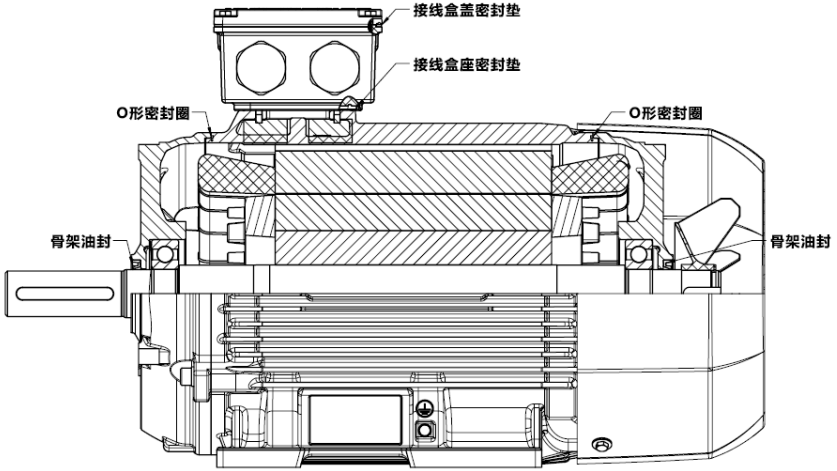

# Disposal

Protecting the environment and preserving its resources are corporate goals of the highest priority for us. Our worldwide environmental management system to ISO 14001 ensures compliance with legislation and sets high standards in this regard. Environmentally friendly design, technical safety and health protection are always firm goals even at the product development stage.

Recommendations for the environmentally friendly disposal of the machine and its components are given in the following section. Be sure to comply with local disposal regulations.

## Country-specific legislation



The machine uses materials that can be recovered or recycled. Correctly separating materials helps to simply recycle important materials.

- When disposing of the machine or of waste that is created during the individual phases of its life cycle, please observe the statutory requirements applicable in the country of use.
- Please contact your local authorities for more information about disposal.

## 6.1 RoHS - restricting the use of certain hazardous substances

In compliance with RoHS ("Restriction of certain Hazardous Substances") we replace substances that are damaging to the environment by those that are not based on state-of-the-art technology. In doing so, safety in operation and handling will take priority at all times.

## 6.2 Information according to Article 33 of the REACH regulation

This product contains one or several subproducts in which the following substance – belonging to the "list of candidates" – exists in a concentration exceeding 0.1 per cent by weight.

- CAS No. 7439-92-1, lead

Based on the currently available information, we assume that this substance does not represent any risk when correctly used, including its disposal.

## 6.3 Preparing for disassembly

Disassembly of the machine must be carried out and/or supervised by qualified personnel with appropriate expert knowledge.

1. Contact a certified waste disposal organization in your vicinity. Clarify what is expected in terms of the quality of dismantling the machine and provision of the components.
2. Follow the five safety rules.
3. Disconnect all electrical connections and remove all cables.
4. Remove all liquids such as oil and cooling liquids. Collect the liquids separately and dispose of them in a professional manner.
5. Detach the machine fixings.
6. Transport the machine to a suitable location for disassembly.

## 6.4 Dismantling the machine

Dismantle the machine using the general procedures commonly used in mechanical engineering.

 <b>WARNING</b>
<b>Machine parts can fall</b>
The machine is made up of heavy parts. These parts are liable to fall during dismantling. This can result in death, serious injury or material damage.
<ul style="list-style-type: none"><li>• Before you release any machine parts, secure them so that they cannot fall.</li></ul>

## 6.5 Disposal of components

The machines consist mainly of steel and various proportions of copper and aluminum. Metals are generally considered to be unlimitedly recyclable.

Sort the components for recycling according to whether they are:

- Iron and steel
- Aluminum
- Non-ferrous metal, e.g. windings

The winding insulation is incinerated during copper recycling.

- Insulating materials
- Cables and wires
- Electronic waste

Process materials and chemicals

Sort the process materials and chemicals for recycling according to whether they are for example:

- Oil
- Grease
- Cleaning substances and solvents
- Paint residues
- Anti-corrosion agent
- Coolant additives such as inhibitors, antifreeze or biocides

Dispose of the separated components according to local regulations or via a specialist disposal company. The same applies for cloths and cleaning substances which have been used while working on the machine.

Packaging material

- If necessary, contact a suitable specialist disposal company.
- Wooden packaging for sea transport consists of impregnated wood. Observe the local regulations.
- The foil used for water-proof packaging is an aluminum composite foil. It can be recycled thermally. Dirty foil must be disposed of via waste incineration.

# INNOMOTICS

售后支持

After-sales support

