

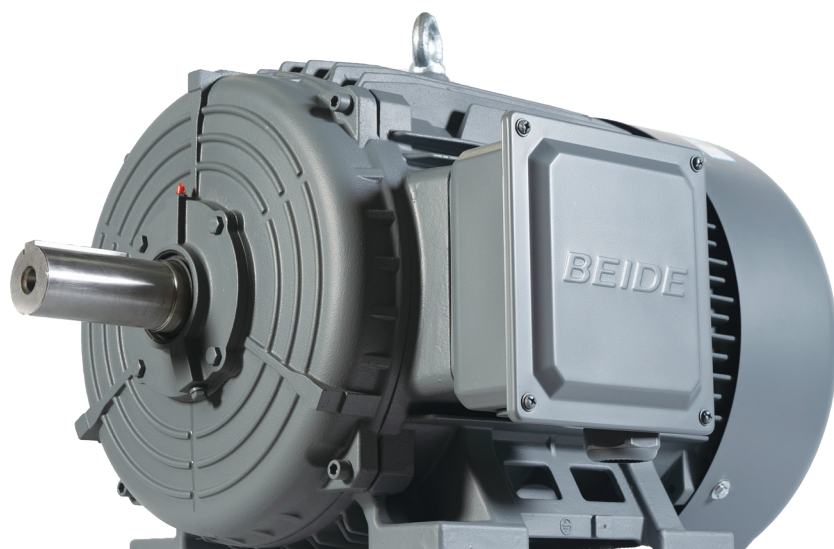

1TL8004 二级能效铸铁系列
低压三相异步电动机
1TL8004 IE4 Cast Iron series Low-voltage
Three-phase Asynchronous Motor

产品样本 Catalog
2026. 06





为更好应对气候变化，快速响应市场需求，聚焦提升能效与可靠性的创新，推动产业绿色低碳转型和可持续发展。2023年7月1日，西门子将其低压至高压电机、齿轮电机、中压变频器 and 电主轴领域等相关业务进行整合，成立了茵梦达（Innomotics GmbH）。茵梦达总部位于德国纽伦堡，业务遍及全球49个国家，拥有16家工厂，全球员工约15000名。

凭借百余年技术积淀和创新，茵梦达将专注于电机和大型传动专业领域。作为行业领军企业，茵梦达将不断推动工业化进程和可持续发展。

茵梦达在华拥有5家运营公司（包括一家区域总部和4家工厂），13家分公司和6家研发中心，其中在南京设立了“茵梦达低压电机事业部全球研发中心”，员工总数约3500人，是茵梦达在全球主要的研发和制造基地。



茵梦达电机（中国）有限公司原名西门子电机（中国）有限公司，于2006年3月1日正式运营，2024年5月正式更名。

从2018年荣获国家绿色工厂，到2019年被认定为国家高新技术企业，再到累计五次荣获西门子中国最佳运营工厂殊荣，茵梦达电机（中国）有限公司一直致力于为客户提供创新、高效、可持续的电机解决方案。

公司拥有员工约2000余人，占地面积18.2万平方米，年产电机约100万台，为茵梦达在华最大的低压、高效电机研发和生产基地。

目录 Contents

概述 Overview	5
变频应用 Converter fed application	15
订货号 Order No.	19
选型技术数据表 Technical data table	22
选件 Options	26
外形尺寸 Dimension drawings	30

概述 Overview

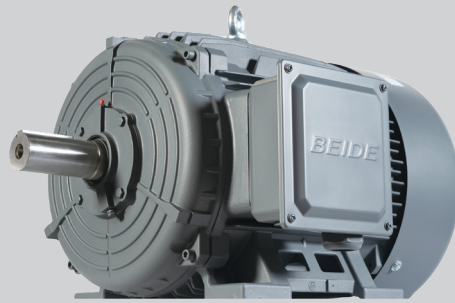

额定功率：0.55 ~ 315 kW

机座号：80 ~ 355

电压与频率：支持多种电压与频率

冷却方式：IC411

注油装置：机座号 180 ~ 355 的电机标配

防护等级：IP55

绝缘等级：F

环境温度：-15 ~ 40 °C

海拔高度：不超过 1000 m

Rated output: 0.55 ~ 315 kW

Frame size: 80 ~ 355

Voltage and Frequency: support multiple voltage and frequency

Cooling method: IC411

Oiling device: FS180 ~ 355 motor as standard

Degree of protection: IP55

Degree of insulation: F

Coolant temperature: -15 ~ 40 °C

Site altitude above sea level: not exceed 1000 m

1TL8004 系列电动机是全新设计的高效低压三相异步电动机，机壳为铸铁，适用于连续工作制（S1）工作运行。1TL8004 系列电动机是全新一代设计的满足国家二级能效的电机，结构新颖、造型美观、噪音低、振动小、绝缘等级高等特点，可用于风机、泵、压缩机、纺织机械、皮带机、搅拌机等多种工业应用领域。

1TL8004 series of motors is the newly designed high efficiency low voltage three phase asynchronous motor, the housing material is cast iron, is designed for continuous duty operation(S1). 1TL8004 series of motors is the new designed IE4 efficiency motors, owns the features of novel structure, beautiful appearance, low noise, small vibration, high degree of insulation, etc, also can be used in the fields of fans, pump, compressors, belt conveyor, blender and textile machine.

参考标准 Reference standards

名称 Title	IEC 标准 IEC standard	中国国家标准 Chinese standard
旋转电动机定额和性能 Rotating electrical machines – Part 1: Rating and performance	IEC 60034-1	GB/T 755
旋转电动机损耗与效率确定的标准测试方法 Rotating electrical machines – Part 2-1: Standard methods for determining losses and efficiency from tests (excluding machines for traction vehicles)	IEC 60034-2	GB/T 1032
旋转电机整体结构的防护等级 (IP 代码) 分级 Rotating electrical machines – Part 5: Degrees of protection provided by the integral design of rotating electrical machines (IP code) - Classification	IEC 60034-5	GB/T 4942.1
旋转电动机冷却方法 Rotating electrical machines – Part 6: Methods of cooling (IC Code)	IEC 60034-6	GB/T 1993
旋转电动机结构型式、安装型式及接线盒位置的分类 (IM 代码) Rotating electrical machines – Part 7: Classification of types of construction, mounting arrangements and terminal box position (IM Code)	IEC 60034-7	GB/T 997
旋转电动机旋转电机线端标志与旋转方向 Rotating electrical machines – Part 8: Terminal markings and direction of rotation	IEC 60034-8	GB/T 1971
旋转电机噪声测定方法及限值 第 3 部分: 噪声限值 Rotating electrical machines – Part 9: Noise limits	IEC 60034-9	GB 10069.3
轴中心高为 56 mm 及以上电机的机械振动 振动的测量、评定及限值 Rotating electrical machines – Part 14: Mechanical vibration of certain machines with shaft heights 56 mm and higher – Measurement, evaluation and limits of vibration severity	IEC 60034-14	GB 10068
旋转电机尺寸和输出功率等级 第 1 部分: 机座号 56 ~ 400 和凸缘号 55 ~ 1080 Rotating electrical machines – Part 1: Frame numbers 56 to 400 and flange numbers 55 to 1080	IEC 60072-1	GB/T 4772.1
中小型旋转电机安全要求 Safety requirements of small and medium size rotating electrical machines		GB 14711
电气绝缘 耐热性和表示方法 Electrical insulation – Thermal evaluation and designation	IEC 60085	GB/T 11021
电工电子产品自然环境条件 温度和湿度 Classification of environmental conditions Part 2-1: Environmental conditions appearing in nature – Temperature and humidity	IEC 60721-2-1	GB/T 4797.1
标准电压 Standard voltages	IEC 60038	GB/T 156

铭牌样例 Nameplate

1TL8004 系列电机铭牌

1TL8004 Motor Nameplate

电机配封闭式轴承铭牌样例

Example of motor with sealed bearing nameplate

















 		THREE-PHASE ASYNCHRONOUS MOTOR 三相异步电动机		Eff.-Grade2 GB18613-2020	
型号 OCV4094A8	1TL8004-0EA42-1AA4-Z	90L	LMH-2406/800003888993/001	Q/321081 KJA017-2024	
⊕ 2.2 kW	50 Hz	7.6/4.40 A	EFF. 88.0 %	IP 55	25 kg
220VΔ /380VY	IM B3	2910 r/min	COSφ 0.86		Th.Cl.155(F)
驱动端: 6205 2Z C3		非驱动端: 6205 2Z C3			
茵梦达电机(中国)有限公司 Innomotics Standard Motors Ltd.					

电机配可再润滑性轴承铭牌样例

Example of motor with regreasable bearing nameplate

 		THREE-PHASE ASYNCHRONOUS MOTOR 三相异步电动机		Eff.-Grade2 GB18613-2020	
型号 OCV4312B8	1TL8004-3AB23-3AA4-Z	315M	LMH-2406/800003888993/001	Q/321081 KJA017-2024	
⊕ 132 kW	50 Hz	240/139 A	EFF. 96.4 %	IP 55	955 kg
380VΔ /660VY	IM B3	1490 r/min	COSφ 0.86		Th.Cl.155(F)
驱动端: 6319 C3		非驱动端: 6319 C3			
润滑脂: 2# Li Grease		油脂量: 驱动端40g / 非驱动端40g			
润滑周期: 5000h					
茵梦达电机(中国)有限公司 Innomotics Standard Motors Ltd.					

安装结构型式 Construction and mounting type

结构型式 Construction type	机座带底脚, 端盖无法兰 With feet and without flange on the end-shield (DE)					
安装型式 Mounting type	IM B3 FS80 ~ 355	IM B6 FS80 ~ 160	IM B7 FS80 ~ 160	IM B8 FS80 ~ 160	IM V5 FS80 ~ 160	IM V6 FS80 ~ 160
示意图 Diagram						
电动机订货号第 14 位号 上对应的字母 Letter, position 14 th of Motor code	A	T	U	V	C	D
结构型式 Construction type	机座不带底脚, 端盖有法兰 Without feet and with flange on the end-shield (DE)			机座带底脚, 端盖有法兰 With feet and with flange on the end-shield (DE)		
安装型式 Mounting type	IM B5 FS80 ~ 280	IM V1 ¹⁾²⁾ FS80 ~ 355	IM V3 ²⁾ FS80 ~ 160	IM B35 FS80 ~ 355	IM V15 FS80 ~ 160	IM V35 FS80 ~ 160
示意图 Diagram						
电动机订货号第 14 位号 上对应的字母 Letter, position 14 th of Motor code	F	G	H	J	W	Y
结构型式 Construction type	机座不带底脚, 端盖有标准小法兰 Without feet and with C-flange on the end-shield (DE)			机座带底脚, 端盖有标准小法兰 With feet and with C-flange on the end-shield (DE)		
安装型式 Mounting type	IM B14 FS80 ~ 112	IM V18 FS80 ~ 112	IM V19 FS80 ~ 112	IM B34 FS80 ~ 112		
示意图 Diagram						
电动机订货号第 14 位号 上对应的字母 Letter, position 14 th of Motor code	K	M	L	N		

1) 室外使用时推荐使用护罩 (选项号 H00) ;

2) 此安装方式中, 标配全圆法兰;

3) 当户外安装时, 推荐对电动机轴采取防护措施, 避免水直接喷射到电动机轴上。

1) At outdoor application, the using of protective cover (Option code H00) is recommended;

2) Full circle flange as standard configuration in this type mounting;

3) At outdoor application, the using of protective measures on motor shaft are recommended.

轴承系统

1TL8004 系列电动机标准配置深沟球轴承或角接触球轴承，这些轴承是密封型的或可再润滑的。

FS80 ~ 160 电动机驱动端与非驱动端轴承浮动；FS180 ~ 355 电动机驱动端轴承浮动，非驱动端轴承固定。

标准配置的轴承可以承受一定的悬臂力，当电动机轴端承受的悬臂力较大时，可以考虑选择增强悬臂力的轴承设计（选件号：L22）。

Bearing system

1TL8004 series motors are supplied with the ball bearing as standard. These bearings are either of the sealed or regreasable type.

For FS80 ~ 160, the floating bearings are assembled. For FS180 ~ 355, floating bearing at DE, and fixed bearing at NDE assembled.

The standard bearing can endure a maximum cantilever force, the increased cantilever bearing design (Option code: L22) should be considered.

轴承选配 Bearing Assignment

机座号 Frame size	极数 Pole	标准配置 Standard design			增强悬臂力设计轴承(选件号L22) Increased cantilever-bearing (Option code:L22)		
		驱动端 轴承 DE bearing	非驱动端轴承 (水平安装) NDE bearing (Horizontal mounting)	非驱动端轴承 (竖直安装) NDE bearing (Vertical mounting)	驱动端 轴承 DE bearing	非驱动端轴承 (水平安装) NDE bearing (Horizontal mounting)	非驱动端轴承 (竖直安装) NDE bearing (Vertical mounting)
80	2, 4, 6	6204 2RZ C3	6204 2RZ C3	6204 2RZ C3	<input type="checkbox"/>	<input type="checkbox"/>	<input type="checkbox"/>
90	2, 4, 6	6205 2RZ C3	6205 2RZ C3	6205 2RZ C3	<input type="checkbox"/>	<input type="checkbox"/>	<input type="checkbox"/>
100	2, 4, 6	6206 2RZ C3	6206 2RZ C3	6206 2RZ C3	6306 2RZ C3	6206 2RZ C3	6206 2RZ C3
112	2, 4, 6	6206 2RZ C3	6206 2RZ C3	6206 2RZ C3	6306 2RZ C3	6206 2RZ C3	6206 2RZ C3
132	2, 4, 6, 8	6208 2RZ C3	6208 2RZ C3	6208 2RZ C3	6308 2RZ C3	6208 2RZ C3	6208 2RZ C3
160	2, 4, 6, 8	6309 2RZ C3	6209 2RZ C3	6209 2RZ C3	<input type="checkbox"/>	<input type="checkbox"/>	<input type="checkbox"/>
180	2, 4, 6, 8	6310 C3	6210 C3	6210 C3	NU310	6210 C3	6210 C3
200	2, 4, 6, 8	6312 C3	6212 C3	6212 C3	NU312	6212 C3	6212 C3
225	2,4,6,8	6313 C3	6213 C3	6213 C3	NU313	6213 C3	6213 C3
250	2, 4, 6, 8	6314 C3	6214 C3	6214 C3	NU314	6214 C3	6214 C3
280	2	6315 C3	6315 C3	6315 C3	NU315	6315 C3	6315 C3
280	4, 6, 8	6316 C3	6316 C3	6316 C3	NU316	6316 C3	6316 C3
315	2	6316 C3	6316 C3	6316 C3	NU316	6316 C3	6316 C3
	4, 6, 8	6319 C3	6319 C3	6319 C3	NU319	6319 C3	6319 C3
355	2	6317 C3	6317 C3	7317	NU317	6317 C3	O.R.
	4, 6, 8	6322 C3	6322 C3	7322	NU322	6322 C3	O.R.

注：DE 驱动端
NDE 非驱动端
— 不能满足
O.R. 须要特殊询价

对160机座，标配轴承配置已做增强悬臂力设计，不需要再加选L22选件

Note: DE Driven end
NDE Non driven end
— Not possible
O.R. Possible on request

For FS160, Increased cantilever-bearing design is utilized as standard. No need for L22

润滑脂寿命和再润滑周期

对于以规定间隔再润滑的电机，轴承寿命可以延长，从而补偿不利因素，诸如温度、安装条件、转速、轴承规格和机械载荷造成的影响。

Grease life and re-greasing interval

For motors which can be regreased at defined regreasing intervals, the bearing lifetime can be extended and/or unfavorable factors such as temperature, mounting conditions, speed, bearing size and mechanical load can be compensated.

润滑脂寿命和再润滑周期（电动机水平安装） Grease life (Horizontal installation)

机座号 Frame size	极数 Poles	润滑脂寿命 Grease lifetime up to CT 40 °C
持久润滑型轴承的润滑脂 Grease for permanent lubrication bearing		
80 ~ 160	2, 4, 6, 8	20000 h
可再润滑型轴承的润滑脂 Grease for regreasable bearing		
180 ~ 250	2	4000 h
	4, 6, 8	8000 h
280 ~ 315	2	3000 h
	4, 6, 8	5000 h
355	2	3000 h
	4, 6, 8	4000 h

当电动机在非正常的条件下运行时，轴承的寿命会缩短。如下面几种情况：

- 当电动机的运行速度高于额定速度时，由于电动机的振动增大，使得轴承受到额外的径向力和轴向力，导致其寿命减少；
- 当环境或设备等因素引起电动机振动加大时，同样轴承也会因此受到额外的径向力和轴向力，而导致其寿命减少；
- 当环境温度每升高 10°C，润滑脂寿命以及再润滑时间缩短一半。

- When motor runs beyond the rated speed, the increase of motor vibration will result in the extra radial and axial force on bearing. This will reduce the life of bearing;
- When the motor vibration increase due to the environment or other equipment, the bearing also will endure more radial and axial force. This also will reduce the life of bearing;
- If the coolant temperature is increased by 10 °C, the grease lifetime and regreasing interval is halved.

电动机轴驱动端允许的最大悬臂力 Permissible cantilever forces on DE shaft

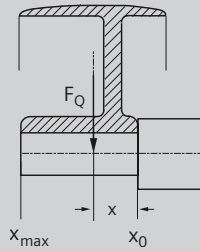

为了计算径向负载的最大悬臂力，距轴肩处的悬臂力 F_Q (N) 必须位于轴伸端以内，（长度为 x ）。长度 x [mm] 是距离轴肩的距离。长度最长为 x_{max} ，与轴伸长度相同。总的悬臂力 F_Q 使用以下公式计算。

$$F_Q = c \cdot F_U$$

预紧力系数 c 是从皮带制造商那得到的经验数值，下面的估算值可以应用。

- 对于一般扁平的皮带， $c = 2$ ；
- 对于 V 型皮带， $c = 2 \sim 2.5$ ；
- 对于特殊的皮带（取决于皮带类型和负载）， $c = 2 \sim 2.5$ 。

计算切向力 F_U (N) 使用下列公式：

$$F_U = 2 \cdot 10^7 \frac{P}{n \times D}$$

- F_U 切向力 (N)
- P 额定功率 (kW)
- n 额定转速
- D 滑轮直径 (mm)

In order to calculate the admissible cantilever forces for a radial load, the line of force (i.e. the centerline of the pulley) of the cantilever force F_Q (N) must lie within the free shaft extension (dimension x). Dimension x [mm] is the distance between the point of application of force F_Q and the shaft shoulder. Dimension x_{max} . Corresponds to the length of the shaft extension. Total cantilever force is calculated using the following equation.

$$F_Q = c \cdot F_U$$

The pre-tension factor c is a value gained from experience from the belt manufacturer. The following approximate value can be assumed.

- For normal flat leather belts with an idler pulley, $c = 2$.
- For v-belts, $c = 2$ to 2.5.
- For special synthetic belts (depending on the type and load),
 $c = 2$ to 2.5.

The circumferential force F_U (N) is calculated using the following equation.

$$F_U = 2 \cdot 10^7 \frac{P}{n \times D}$$

- F_U circumferential force in N
- P rated motor power (transmitted power) in kW
- n rated motor speed
- D pulleys in mm.

假设电动机不受任何轴向力，下面的表格中列出了允许的径向悬臂力值（单位：牛顿）。

The table below contains the permissible Radial Force values in Newtons with the assumption of zero axial forces.

标准电机最大悬臂力 Admissible cantilever forces for standard version				增强悬臂力的轴向设计（编号 L22） Bearing design for increased cantilever forces Order code L22	
机座号 Frame size	极数 Number of poles	悬臂力范围 Admissible cantilever force		悬臂力范围 Admissible cantilever force	
		for x_0 N	for x_{max} N	for X_0	for X_{max}
80M	2	620	510	-	-
	4	790	640	-	-
	6	910	740	-	-
90S 90L	2	700	560	-	-
	4	880	720	-	-
	6	1020	820	-	-
100L	2	1000	850	1520	1300
	4	1100	950	1760	1500
	6	1300	1100	2050	1750
112M	2	980	840	1500	1270
	4	1150	970	1800	1520
	6	1300	1100	2060	1740
132S 132M	2	1500	1205	2190	1750
	4	1820	1490	2690	2210
	6	1955	1605	2960	2420
	8	2225	1785	3320	2660
160L 160M	2	2880	2325	2880	2325
	4	3490	2820	3490	2820
	6	3850	3100	3850	3100
	8	4350	3510	4350	3510
180	2	3550	2950	9250	5200
	4	4450	3650	11300	6020
	6	5050	4200	12850	6030
	8	5600	4650	13950	6030
200	2	4800	4000	12480	5300
	4	6000	5050	15000	6150
	6	6700	5600	15000	6150
	8	7100	6000	15320	6150
225	2	5200	4350	14500	5500
	4	6400	5200	16000	6250
	6	7150	5800	16000	6250
	8	8000	6500	16000	6250
250M	2	5360	4330	14690	5700
	4	6540	5520	16090	6300
	6	7750	5890	16090	6330
	8	8680	5890	16090	6330
280S 280M	2	5830	4840	18500	7800
	4	7870	6580	24180	8460
	6	9230	7580	24900	8460
	8	10400	7950	28600	8460
315S 315M 315L	2	6150	5200	21350	9050
	4	8790	7350	34240	13200
	6	10350	8550	38600	13100
	8	11450	9450	42200	12950
355M 355L	2	6430	5700	22920	12300
	4	12000	10400	44450	20800
	6	13050	11300	49500	20500
	8	14500	12550	54000	20500

接线盒技术参数 Connection boxes technical data

机座号 Frame size	接线螺钉螺纹 Contact screw thread	外接电缆直径 (mm) Outer cable diameter (sealing range)	进线孔尺寸 Cable entry size
80 ~ 90	M4	13 ~ 18	M25 × 1.5
100	M5	18 ~ 23	M32 × 1.5+M32 × 1.5
112			
132			
160	M5	22 ~ 28	M40 × 1.5+M40 × 1.5
180			
200	M8	32 ~ 36	M50 × 1.5+M50 × 1.5
225			
250	M10	37 ~ 44	M63 × 1.5+M63 × 1.5
280			
315	M12	37 ~ 44	M63 × 1.5+M63 × 1.5
355	M16	38 ~ 47	M72 × 2 + M72 × 2

振动

所有电动机转子都使用半键按照 A 级（标准）振动等级进行动态平衡。

电动机在空载时测得振动速度有效值不超过下表中的 A 级所列值。

Vibration

1TL8004 rotors are dynamically balanced to severity grade A using a half key.

Table below contains the effective vibration values for unloaded motors.

振动等级 Vibration Grade	机座号 Frame size (mm)	56 ≤ FS ≤ 132		H > 132	
	安装方式 Mounting	位移 Vibration displacement/um	速度 Vibration velocity/(mm/s)	位移 Vibration displacement/um	速度 Vibration velocity/(mm/s)
A	自由悬置 Free suspension	45	2.8	45	2.8
	刚性安装 Rigid mounting	-	-	37	2.3 2.8 ¹⁾
B	自由悬置 Free suspension	18	1.1	29	1.8
	刚性安装 Rigid mounting	-	-	24	1.5 1.8 ¹⁾

注：

¹⁾ 该值为 GB/T 10068-2020 中定义的轴中心高 H>132mm 的两极电机，当两倍电网频率占主导时的振动速度限值。

Note:

¹⁾ The level are vibration velocity limit when the twice line frequency vibration level is dominant defined by GB/T 10068-2020, for 2p motors that frame size bigger than 132mm.

防潮加热保护

当电动机处于较为恶劣的环境时，比如湿度非常大或者昼夜温差比较大，电动机的绕组很可能出现凝露的现象，这样会带来电动机烧毁的风险。对于这种情况，建议对电动机绕组配置防潮加热带（选件号：Q04）进行保护。

电动机防潮加热带必须在电动机工作过程中处于不工作状态；当电动机停机时，防潮加热带必须启动工作，为绕组加热。防潮加热带的电气参数如下表所示。

防潮加热带电气参数 Electrical data of Anti-condensation heater

机座号 Frame size	功率 Power (W)	电压 Voltage (V)
80 ~ 90	20	220
100 ~ 112	30	220
132 ~ 160	40	220
180 ~ 200	50	220
225 ~ 280	60	220
315	80	220
355	100	220

电气特性

额定输出

1TL8004电动机的额定功率是指电动机在连续运行的情况下 S1 (IEC 60034-1)，此时周围环境温度为 $-15^{\circ}\text{C} \sim 40^{\circ}\text{C}$ ，海拔高度不超过 1000 m。

电压、频率

IEC 60034-1 将电压和频率的偏差分为 A 类（电压偏差 $\pm 5\%$ ，频率偏差 $\pm 2\%$ ）和 B 类（电压偏差 $\pm 10\%$ ，频率偏差 $+3\% / -5\%$ ）。电动机均能够在 A 类和 B 类提供额定转矩。在 A 类中，温度比正常运行下温度大约提升 10 K。

Anti-condensation heater

Motors whose windings are at risk of condensation due to the climatic conditions, e.g. inactive motors in humid atmospheres or motors that are subjected to widely fluctuating temperatures can be equipped with anti-condensation heaters (Option code: Q04).

Anti-condensation heaters must be switched off during operation. When motor shut down, the heaters must be switched on.

Electrical design

Rated Output

1TL8004 motors rated output powers means that the motor runs under continuous duty S1 (IEC 60034 - 1) operation when operated at ambient temperature from -15°C to 40°C and at altitudes of up to 1000 m over sea.

Voltage and Frequency

IEC 60034-1 differentiates between Category A (combination of voltage deviation $\pm 5\%$ and frequency deviation $\pm 2\%$) and Category B (combination of voltage deviation $\pm 10\%$ and frequency deviation $+3\% / -5\%$) for voltage and frequency fluctuations. The motors can supply their rated torque in both Category A and B. In Category A, the temperature rise is approximately 10 K higher than during normal operation.

标准 Standard 60034 - 1	类别 Category A	类别 Category B
电压偏差 Voltage deviation	±5 %	±10 %
频率偏差 Frequency deviation	±2 %	+3 % / -5 %
根据标准，不推荐电动机在 B 类情况下长时间运行 According to the standard, longer operation is not recommended for Category B.		

电气数据公差

- 效率 η

$-0.15 \times (1 - \eta)$

效率 η 为小于 1 的值

- 功率因数: $(1 - \cos \phi) / 6$

最小绝对值: 0.02

最大绝对值: 0.07

- 转差率: ±20 % (电动机的偏差 < 1 kW ± 30 % 时是允许的)

- 堵转电流: +20 %

- 堵转转矩: -15 % ~ +25 %

- 最大转矩: -10 %

- 转动惯量: ±10 %

Tolerance for electrical data

- Efficiency η

$-0.15 \times (1 - \eta)$

With η being a decimal number

- Power factor - $(1 - \cos \phi) / 6$

Minimum absolute value: 0.02

Maximum absolute value: 0.07

- Slip ±20 % (for motors < 1 kW ±30 % is admissible)

- Locked-rotor current +20 %

- Locked-rotor torque -15 % to +25 %

- Breakdown torque -10 %

- Moment of inertia ±10 %

变频应用 Converter fed application

1TL8004 电动机适于变转速、恒转速的各种应用，如风机、泵、压缩机、纺织机械等。

1TL8004 电动机的标准绝缘系统设计要求，FS80~90 能够保证其在变频器供电电压不超过 380V 时正常运行，FS100-355 能够保证其在变频器供电电压不超过 460 V 时正常运行。

1TL8004 电动机带有特定的负载时能够使用变频器驱动，其特定的负载扭矩如以下图表所示：

1TL8004 motors are suitable for pumps, fans, compressors, textile machine and mechanical machine applications where variable or constant speed is required.

The standard insulation of the 1TL8004 motors is designed such that operation is possible on the converter at mains voltage up to 380V for FS80~90, converter at main voltage up to 460 V for FS100-355.

1TL8004 motors are capable for converter-fed operation with certain characteristics load, of which the load torque characteristics is referred in the following diagram:

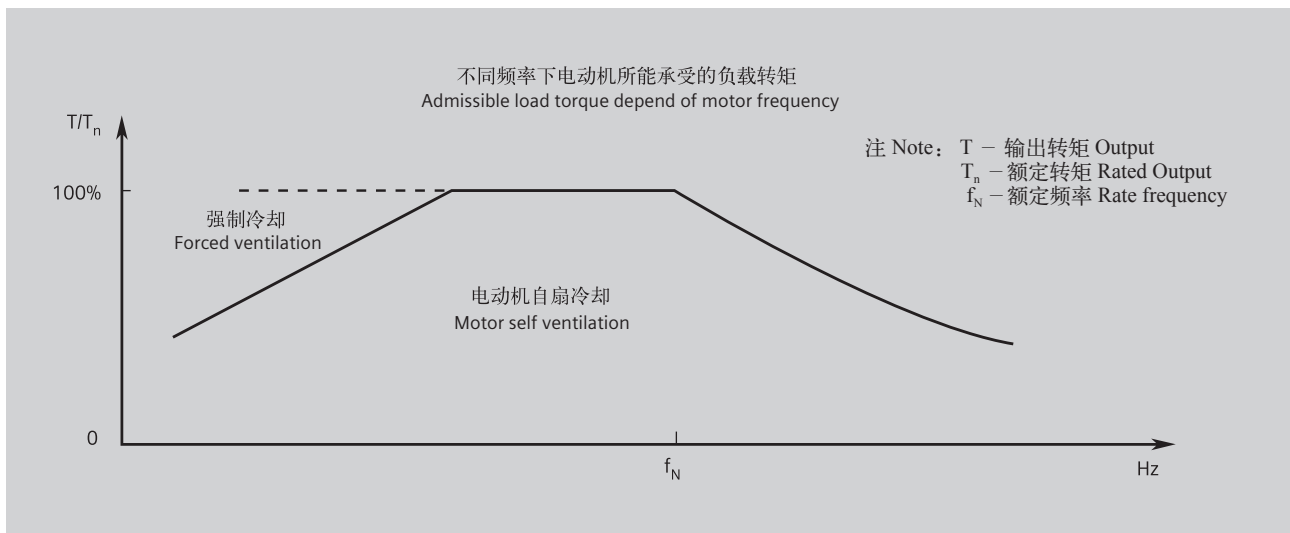

当 1TL8004 电动机变频应用（变频器供电），且输出额定功率时，电动机的使用温度等级为 155 (F)。为了避免杂散电流对电动机轴承的损坏，推荐 FS250-355 电动机使用绝缘轴承。请向茵梦达咨询关于绝缘轴承的详细信息。

当负载转矩在允许的转矩范围内时，电动机能够自扇冷却；当负载转矩超过所允许的转矩时，电动机需要强迫冷却。

在电动机运行速度超过额定转速时，噪声和振动值将增加，并且轴承的寿命将缩短。需要注意再润滑周期和润滑脂的寿命。

At rated output with converter fed operation, the motors will be used in temperature class 155 (F). To prevent damage as a result of bearing currents, insulated bearings are recommended to be assembled for frame size 250-355 and above. Please inquire INNOMOTICS about the detailed information of insulated bearing.

By usage with admissible torque and below, the motor can be operated with self cooling; by usage over the admissible torque line, the motor with forced ventilation is needed.

At operating speeds above rated speed the noise and vibration levels increase and the bearing life time reduce. Attention should be paid to the re-greasing intervals and the grease service life.

1TL8004 电动机所允许的最大安全转速如下表

The allowed maximum safe operating speed of 1TL8004 motors shows the diagram

机座号 Frame size	2 极 2 pole		4 极 4 pole		6 极 6 pole		8 极 8 pole	
	最高转速 Max.rpm	最大频率 fmax	最高转速 Max.rpm	最大频率 fmax	最高转速 Max.rpm	最大频率 fmax	最高转速 Max.rpm	最大频率 fmax
80	5200	87	3600	120	2400	120	-	-
90	5200	87	3600	120	2400	120	-	-
100	5200	87	3600	120	2400	120	1800	120
112	5200	87	3600	120	2400	120	1800	120
132	4500	75	2700	90	2400	120	1800	120
160	4500	75	2700	90	2400	120	1800	120
180	4500	75	2700	90	2400	120	1800	120
200	4500	75	2300	77	1800	90	1400	93
225	3600	60	2300	77	1800	90	1400	93
250	3600	60	2300	77	1800	90	1400	93
280	3600	60	2300	77	1800	90	1400	93
315	3600	60	2300	77	1800	90	1400	93
355	3600	60	2300	77	1800	90	1400	93

独立驱动风扇技术参数 Technical data for separately fan



独立驱动风扇技术参数 Technical data for separately fan

对应电动机机座号 Motor frame size	额定电压 (V) rated voltage	额定频率 (Hz) Rated frequency	功率 (W) Rated output	电流 (A) Current	ΔL
80	220D/380Y	50	30	0.14/0.08	60
90	220D/380Y	50	30	0.14/0.08	70
100	220D/380Y	50	52	0.21/0.12	75
112	220D/380Y	50	52	0.21/0.12	90
132	220D/380Y	50	45	0.35/0.2	50
160	220D/380Y	50	45	0.35/0.2	65
180	220D/380Y	50	120	1.04/0.6	71
200	220D/380Y	50	120	1.04/0.6	64
225	220D/380Y	50	120	1.04/0.6	75
250	220D/380Y	50	230	1.73/1.0	72
280	220D/380Y	50	230	1.73/1.0	110
315(2P)	220D/380Y	50	1100	4.33/2.5	145
315(4~8P)	220D/380Y	50	370	1.91/1.1	95
355	220D/380Y	50	550	2.18/1.26	80

注： 风扇可以在 210 ~ 240VD/360 ~ 420VY 50Hz 电源供电下运行，也可以在 220 ~ 260VD/380 ~ 480VY 60Hz 电源供电下运行。其他电压电源供电，须特殊询价。

Note: The fan can be running with supply 210 ~ 240VD/360 ~ 420VY 50Hz, and also 220 ~ 260VD/380 ~ 480VY 60Hz. Other voltage supply, possible on request.

风机电机参数 Technical data for fan motor

对于某些客户现场有外部冷却设备的应用，可以提供无风扇和风扇罩的风机电机，风机电机的选件号为 F90。当电机无风扇和风扇罩时，电动机的长度将减少 Δl 。

For some special application with external cooling facility, we can provide motor without fan and fan cover, the option code is F90. When motor without fan and fan cover, the length will decrease Δl .

对应电动机机座号 motor frame size	F90 电机减少长度 Δl Length decrease of motor Δl
80	50
90	60
100	70
112	65
132	75
160	90
180	105
200	110
225	120
250	125
280	135
315	185
355	190

型号与订货号 Motor Type and Order No.

电动机订货号

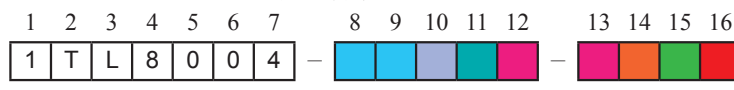

低压系列电动机 Low-voltage motor series

0 = 铸铁壳
0 = Cast Iron

效率等级 Efficiency Grade

4 = 中国能效等级 2 级, IE4 效率等级
4 = China energy efficiency grade 2, IE4 efficiency

机座号编号 Code of frame size

0D = 80 / 0E = 90
1A = 100 / 1B = 112 / 1C = 132 / 1D = 160 / 1E = 180
2A = 200 / 2B = 225 / 2C = 250 / 2D = 280
3A = 315 / 3B = 355

极数编号 Code of poles

A = 2 / B = 4 / C = 6 / D = 8

机座长度编号 Code of frame length

0 or 1 = S (short) / 2 or 3 or 4 = M (medium) / 4 or 5 or 6 or 7 = L (long)

电压, 连接方式和频率编号 Code of voltage, connections and frequency

22 = 230VD / 400VY 50Hz 35 = 415VD 50Hz
21 = 220VD / 380VY 50Hz 23 = 240VD / 415VY 50Hz 90¹⁾ = 特殊电压与频率 special voltage & frequenc
33 = 380VD / 660VY 50Hz 34 = 400VD / 690VY 50Hz

结构和安装方式编号 Code of Construction and mounting type

T²⁾ = IM B6
A²⁾ = IM B3 U²⁾ = IM B7 W²⁾ 4) = IM V15 M²⁾ 3) 4) = IM V18
J²⁾ = IM B35 V²⁾ = IM B8 Y²⁾ = IM V35 L²⁾ 4) = IM V19
F²⁾ 3) = IM B5 C²⁾ 4) = IM V5 G²⁾ 3) 4) = IM V1 N²⁾ = IM B34
K²⁾ 3) = IM B14 D²⁾ = IM V6 H²⁾ 3) = IM V3

绕组保护编号 Code of winding protection

A = 无绕组保护 without winding protection
B⁵⁾ = 绕组带 3 个 PTC 热敏电阻用于跳闸 3 PTC thermistors for tripping
C⁵⁾ = 绕组带 6 个 PTC 热敏电阻用于报警和跳闸 6 PTC thermistors for alarm and tripping
H⁸⁾⁵⁾ = 绕组带 3 个 Pt100 测温元件 3 resistance thermometers Pt100
J⁸⁾⁵⁾ = 绕组带 6 个 Pt100 测温元件 6 resistance thermometers Pt100
Z⁶⁾ = 其他绕组保护 Other temperature for winding protection

接线盒位置编号 (从驱动端看) Code location of connection box (view from drive end)

4 = 顶端出线 top / 5⁷⁾ = 右端出线 on RHS / 6⁷⁾ = 左端出线 on LHS

型号与订货号 Motor Type and Order No.

附注:

- 1) 用电压编号 90 及相应选件号来定制其它电压（参见选件描述）；
- 2) 铭牌上标有结构型式。若需要冷凝水排放孔（订货号：H03），则必须指明电机的安装结构型式，以便在制造过程中确定冷凝水排放孔的具体位置；
- 3) 对于 IM B5、IM V1、IM V3、IM B14、IM V18 和 IM V19 安装结构型式电动机，须指定电动机订货号第 16 位数字为“4”；
- 4) 电动机标配无防雨罩，但如需要加带防雨罩用于防护时，须订购选件号 H00；
- 5) 选择此选件，接线盒将更改为铸铁壳；
- 6) 请向茵梦达另行咨询；
- 7) FS80 ~ 112 进线孔的方向朝向非驱动端；
- 8) 该选件仅适用于 100-355 机座。

Foot note:

- 1) Order other voltages with voltage code 90 and the corresponding Option code (see under "Option") .
- 2) The type of construction is stamped on the rating plate. When ordering with condensation drainage holes (order code H03), it is absolutely necessary to specify the type of construction for the exact position of the condensation drainage holes during manufacture.
- 3) For motor with IM B5, IM V1, IM V3, IM B14, IM V18 and IM V19 construction and mounting type, the 16th digit of motor order No. must be "4";
- 4) Without canopy, for protective cover with canopy needed Option code H00.
- 5) Choose this option, the connection box will be changed to cast iron.
- 6) Please specially consult with INNOMOTICS.
- 7) FS80 ~ 112 cable entry on connection box towards the non-drive.
- 8) The option is accessible on FS100-355.

电机型号 ¹⁾ Motor type	
	1 2 3 4 5 6 7 8 9
	0 C V 4 □ □ □ □ 8
亚太系列 Asia pacific	
机壳材料 Housing material C = 铸铁 Cast iron	
冷却方式 Cooling method V = 空冷 ventilated	
能效等级, Energy efficiency grade 4 = 中国能效等级 2 级, IE4 效率等级 4 = China energy efficiency grade 2, IE4 efficiency	
机座号 Frame size 08 = 80; 09 = 90; 10 = 100; 11 = 112; 13 = 132; 16 = 160; 18=180; 20=200; 22=225; 25 = 250; 28 = 280; 31 = 315; 35 = 355	
铁心长 Core length	
极数 Poles A = 2; B = 4; C = 6; D = 8	

¹⁾ 电机型号可用于能效备案及查询。

¹⁾ Motor type can be used for energy efficiency filing.

型号与订货号 Motor Type and Order No.

订货号样例:

2 级能效低压三相异步电动机

4 极, 132 kW, IM B3, 380VD / 660VY 50 Hz, IP55, 接线盒位置处于右侧, 进线孔向下 (从驱动端看)。

电动机订货号: 1TL8004-3AB23-3AA5

Order No. example:

China Energy Efficiency Grade2 low voltage three phase asynchronous motor

4-pole, 132 kW, IM B3, 380VD/660VY 50 Hz, IP55, connection box at right side and cable entry at bottom (view from DE)

Motor order code: 1TL8004-3AB23-3AA5

1	T	L	8	0	0	4	-	3	A	B	2	3	-	3	A	A	5
---	---	---	---	---	---	---	---	---	---	---	---	---	---	---	---	---	---

2 级能效铸铁低压三相异步电动机
China Energy Efficiency Grade2 Cast Iron
Low-voltage Three-phase Motor

机座号 Frame size: 315

极数 Poles: 4

铁心长度 Iron core length: 中机座 (M)

电压, 连接方式和频率 Voltage, connection method and frequency: 380VD/660VY 50Hz

结构型式 Construction: IM B3

绕组保护 Winding protection None: 无

接线盒位置 Connection box position at right side: 右侧

选型技术数据表 Technical data table

铸铁壳系列电机 Cast Iron Motors

中国能效等级 2 级, IE4

机座号 Frame Size	额定 功率 Rate Output 50 Hz	电动机 型号 Motor type	订货号 Order No.	额定 转速 Rated Speed	效率 — 参照 GB18613-2020 效率等级 2 Efficiency is in accordance with the efficiency level 2 of GB18613-2020				额定 转矩 Rated torque	起动 电流 / 额定 电流 Starting current /Rated current	起动 转矩 / 额定 转矩 Starting torque/ Rated torque	最大 转矩 / 额定 转矩 Max torque /Rated torque	转动 惯量 Moment of Inertia	重量 IMB3 Weight	噪声 Noise
					效率 (100% 负载) Efficiency at (50 Hz) 4/4 load	效率 (75% 负载) Efficiency at (50 Hz) 3/4 load	功率 因数 Power factor	额定 电流 Rated current							
3000rpm 2 极 2-pole															
220VD / 380VY 50HZ															
80M	0.75	0CV4082A8	1TL8004-0DA22-1 □□□	2885	83.5	83.3	0.83	1.64	2.5	7.9	2.6	3.1	0.00125	18	51/62
80M	1.1	0CV4083A8	1TL8004-0DA32-1 □□□	2900	85.2	85.0	0.83	2.35	3.6	8.0	3.0	3.3	0.00155	20	51/62
90S	1.5	0CV4090A8	1TL8004-0EA02-1 □□□	2910	86.5	86.2	0.85	3.10	4.9	9.7	3.2	3.2	0.00304	25	55/67
90L	2.2	0CV4094A8	1TL8004-0EA42-1 □□□	2910	88.0	87.8	0.86	4.40	7.2	9.7	3.4	3.5	0.0039	30	55/67
100L	3	0CV4104A8	1TL8004-1AA42-1 □□□	2925	89.1	90.0	0.87	5.9	9.8	8.5	2.8	3.3	0.0089	42	62/74
3000rpm 2 极 2-pole															
380VD / 660VY 50HZ															
112M	4	0CV4112A8	1TL8004-1BA23-3 □□□	2940	90.0	90.7	0.88	7.7	13	8.5	2.7	3	0.013	53	65/77
132S	5.5	0CV4130A8	1TL8004-1CA03-3 □□□	2950	90.9	91.5	0.88	10.4	17.8	8.5	2.6	3.6	0.024	66	67/79
132S	7.5	0CV4131A8	1TL8004-1CA13-3 □□□	2950	91.7	92.3	0.89	14	24.3	8.5	2.8	3.8	0.028	74	67/79
160M	11	0CV4162A8	1TL8004-1DA23-3 □□□	2955	92.6	93.0	0.89	20.5	35.5	8	2.6	3	0.061	125	69/81
160M	15	0CV4163A8	1TL8004-1DA33-3 □□□	2960	93.3	93.6	0.89	27.5	48.4	8.5	2.8	3.5	0.073	134	69/81
160L	18.5	0CV4164A8	1TL8004-1DA43-3 □□□	2960	93.7	94.1	0.89	33.5	59.7	8.5	3	3.5	0.080	151	69/81
180M	22	0CV4182A8	1TL8004-1EA23-3 □□□	2972	94.0	94.1	0.89	40	70.7	8.5	2.6	3.4	0.17	203	70/83
200L	30	0CV4204A8	1TL8004-2AA43-3 □□□	2970	94.5	94.6	0.89	54	96.5	8.5	2.6	3.1	0.410	276	71/84
200L	37	0CV4205A8	1TL8004-2AA53-3 □□□	2972	94.8	94.8	0.89	67	119	8.5	2.6	3.1	0.428	284	71/84
225M	45	0CV4222A8	1TL8004-2BA23-3 □□□	2979	95.0	94.9	0.89	81	144	8.5	2.8	3.2	0.56	344	72/85
250M	55	0CV4252A8	1TL8004-2CA23-3 □□□	2982	95.3	95.3	0.89	99	176	8.5	2.8	3.0	0.81	435	75/89
280S	75	0CV4280A8	1TL8004-2DA03-3 □□□	2978	95.6	95.6	0.90	132	241	8.5	2.8	3.2	0.95	533	77/91
280M	90	0CV4282A8	1TL8004-2DA23-3 □□□	2978	95.8	95.9	0.90	159	289	8.5	2.7	3.6	1.06	588	77/91
315S	110	0CV4310A8	1TL8004-3AA03-3 □□□	2982	96.0	95.9	0.89	196	352	8.5	2.1	2.4	1.85	820	77/92
315M	132	0CV4312A8	1TL8004-3AA23-3 □□□	2982	96.2	96.2	0.89	235	423	8.5	2.5	2.7	2.15	895	77/92
315L	160	0CV4315A8	1TL8004-3AA53-3 □□□	2982	96.3	96.4	0.89	285	512	8.5	2.5	2.6	2.47	970	77/92
315L	185	0CV4316A8	1TL8004-3AA63-3 □□□	2982	96.5	96.6	0.89	325	592	8.5	2.7	2.6	2.85	1080	77/92
315L	200	0CV4317A8	1TL8004-3AA73-3 □□□	2975	96.5	96.8	0.89	355	642	7.5	2.3	2.2	2.85	1100	77/92
355M	220	0CV4352A8	1TL8004-3BA23-3 □□□	2986	96.5	96.3	0.91	380	704	8.5	2.6	2.6	2.91	1430	82/97
355M	250	0CV4353A8	1TL8004-3BA33-3 □□□	2982	96.5	96.4	0.91	435	801	8.5	2.4	2.4	2.91	1430	82/97
355L	280	0CV4355A8	1TL8004-3BA53-3 □□□	2985	96.5	96.4	0.91	485	896	8.5	3.0	3.1	3.41	1570	82/97
355L	315	0CV4356A8	1TL8004-3BA63-3 □□□	2982	96.5	96.4	0.91	550	1009	8.5	3.0	3.1	3.41	1600	82/97

注:

- 关于其他电压与频率、绕组保护及接线盒位置的编码, 请见“订货号”部分;
- 噪声值仅适用于电动机在 50 Hz 电源直接供电且空载运行时的情况, 容差为 +3 dB。

Note:

- About the code of other voltage and frequency, winding protection and connection box position, please refer to Orde No.
- Noise value is only applicable to the direct power supply of the motor in 50Hz power supply and the condition of no-load operation, the tolerance is +3dB.

选型技术数据表 Technical data table

铸铁壳系列电机 Cast Iron Motors

中国能效等级 2 级, IE4

机座号 Frame Size	额定 功率 Rate Output 50 Hz	电动机 型号 Motor type	订货号 Order No.	额定 转速 Rated Speed	效率 — 参照 GB18613-2020 效率等级 2 Efficiency is in accordance with the efficiency level 2 of GB18613-2020				额定 转矩 Rated torque	起动 电流 / 额定 电流 Starting current /Rated current	起动 转矩 / 额定 转矩 Starting torque /Rated torque	最大 转矩 / 额定 转矩 Max torque /Rated torque	转动 惯量 Moment of Inertia	重量 IMB3 Weight	噪声 Noise
					效率 (100% 负载) Efficiency at (50 HZ) 4/4 load	效率 (75% 负载) Efficiency at (50 HZ) 3/4 load	功率 因数 Power factor	额定 电流 Rated current							
1500rpm 4 极 4-pole															
220VD / 380VY 50HZ															
80M	0.55	0CV4082B8	1TL8004-0DB22-1 □□□□	1445	83.9	83.5	0.74	1.35	3.6	7.0	2.4	2.8	0.0031	20	45/56
80M	0.75	0CV4083B8	1TL8004-0DB32-1 □□□□	1445	85.7	85.6	0.74	1.80	5.0	7.0	3.0	3.1	0.00378	22	45/56
90S	1.1	0CV4090B8	1TL8004-0EB02-1 □□□□	1450	87.2	86.5	0.75	2.55	7.2	8.2	3.0	3.8	0.005	26	47/59
90L	1.5	0CV4094B8	1TL8004-0EB42-1 □□□□	1450	88.2	87.5	0.76	3.40	9.9	8.2	3.0	3.8	0.0064	31	47/59
100L	2.2	0CV4104B8	1TL8004-1AB42-1 □□□□	1470	89.5	89.6	0.79	4.75	14.3	8.5	2.4	3.8	0.0189	49	52/64
100L	3	0CV4105B8	1TL8004-1AB52-1 □□□□	1470	90.4	90.6	0.8	6.3	19.5	8.9	2.8	3.8	0.0207	52	52/64
1500rpm 4 极 4-pole															
380VD / 660VY 50HZ															
112M	4	0CV4112B8	1TL8004-1BB23-3 □□□□	1470	91.1	91.5	0.8	8.3	26	8.5	2.9	3.8	0.025	58	53/65
132S	5.5	0CV4130B8	1TL8004-1CB03-3 □□□□	1475	91.9	92.4	0.8	11.4	35.6	8	2.6	3.2	0.046	75	59/71
132M	7.5	0CV4132B8	1TL8004-1CB23-3 □□□□	1475	92.6	93.0	0.81	15.2	48.6	8	2.8	3.5	0.059	90	59/71
160M	11	0CV4162B8	1TL8004-1DB23-3 □□□□	1482	93.3	93.6	0.82	22	70.9	8.5	3.2	3.3	0.14	138	61/73
160L	15	0CV4164B8	1TL8004-1DB43-3 □□□□	1482	93.9	94.2	0.82	29.5	96.7	8.5	2.9	3.5	0.16	157	61/73
180M	18.5	0CV4182B8	1TL8004-1EB23-3 □□□□	1480	94.2	94.6	0.82	36.5	119	7.9	2.6	3.2	0.25	210	63/76
180L	22	0CV4184B8	1TL8004-1EB43-3 □□□□	1480	94.5	94.8	0.82	43	142	8.5	2.8	3.6	0.27	222	63/76
200L	30	0CV4205B8	1TL8004-2AB53-3 □□□□	1486	94.9	95.4	0.82	59	193	8	2.8	3	0.77	271	63/76
225S	37	0CV4220B8	1TL8004-2BB03-3 □□□□	1486	95.2	95.6	0.85	69	238	8.5	2.6	3	0.79	346	65/79
225M	45	0CV4222B8	1TL8004-2BB23-3 □□□□	1488	95.4	95.7	0.85	84	289	8.5	2.8	3.0	0.94	391	65/79
250M	55	0CV4252B8	1TL8004-2CB23-3 □□□□	1488	95.7	96.0	0.86	102	353	8.5	2.5	3.3	1.43	481	66/80
280S	75	0CV4280B8	1TL8004-2DB03-3 □□□□	1488	96.0	96.3	0.87	136	481	8.5	2.8	3.0	1.85	583	66/80
280M	90	0CV4282B8	1TL8004-2DB23-3 □□□□	1488	96.1	96.5	0.88	162	578	8.5	2.8	3.0	2.15	654	66/80
315S	110	0CV4310B8	1TL8004-3AB03-3 □□□□	1491	96.3	96.5	0.86	200	705	8.5	2.8	2.5	3.35	915	69/84
315M	132	0CV4312B8	1TL8004-3AB23-3 □□□□	1490	96.4	96.7	0.86	240	846	7.8	2.6	2.3	3.53	955	69/84
315L	160	0CV4315B8	1TL8004-3AB53-3 □□□□	1490	96.6	96.9	0.87	290	1026	8.5	3.0	2.2	4.24	1120	71/86
315L	185	0CV4316B8	1TL8004-3AB63-3 □□□□	1490	96.7	97.0	0.87	335	1186	8.5	3.1	2.2	4.64	1180	71/86
315L	200	0CV4317B8	1TL8004-3AB73-3 □□□□	1490	96.7	97.0	0.87	360	1282	8.5	3.2	2.3	4.92	1220	71/86
355M	220	0CV4352B8	1TL8004-3BB23-3 □□□□	1490	96.7	96.9	0.88	395	1410	8.5	2.5	2.8	5.7	1630	76/91
355M	250	0CV4353B8	1TL8004-3BB33-3 □□□□	1490	96.7	96.9	0.88	445	1602	8.5	2.3	2.8	5.92	1670	76/91
355L	280	0CV4355B8	1TL8004-3BB53-3 □□□□	1490	96.7	96.9	0.88	500	1795	8.5	2.4	2.6	6.19	1760	76/91
355L	315	0CV4356B8	1TL8004-3BB63-3 □□□□	1490	96.7	97.0	0.88	560	2019	8.5	2.3	2.6	6.67	1840	76/91

注:

- 关于其他电压与频率、绕组保护及接线盒位置的编码, 请见“订货号”部分;
- 噪声值仅适用于电动机在 50 Hz 电源直接供电且空载运行时的情况, 容差为 +3 dB。

Note:

- About the code of other voltage and frequency, winding protection and connection box position, please refer to Orde No.
- Noise value is only applicable to the direct power supply of the motor in 50Hz power supply and the condition of no-load operation, the tolerance is +3dB.

选型技术数据表 Technical data table

铸铁壳系列电机 Cast Iron Motors

中国能效等级 2 级, IE4

机座号 Frame Size	额定 功率 Rate Output 50 Hz	电动机 型号 Motor type	订货号 Order No.	额定 转速 Rated Speed	效率 — 参照 GB18613-2020 效率等级 2 Efficiency is in accordance with the efficiency level 2 of GB18613-2020				额定 转矩 Rated torque	起动 电流 / 额定 电流 Starting current /Rated current	起动 转矩 / 额定 转矩 Starting torque/ Rated torque	最大 转矩 / 额定 转矩 Max torque / Rated torque	转动 惯量 Moment of Inertia	重量 IMB3 Weight	噪声 Noise
					效率 (100% 负载) Efficiency at (50 HZ) 4/4 load	效率 (75% 负载) Efficiency at (50 HZ) 3/4 load	功率 因数 Power factor	额定 电流 Rated current							
1000rpm 6 极 6-pole															
220VD / 380VY 50HZ															
80M	0.55	0CV4083C8	1TL8004-0DC32-1 □□□	945	80.9	79.7	0.66	1.57	5.6	5.0	1.9	2.1	0.00471	23	44/55
90S	0.75	0CV4090C8	1TL8004-0EC02-1 □□□	960	82.7	81.8	0.70	1.97	7.5	6.1	2.1	2.8	0.0064	27	45/57
90L	1.1	0CV4094C8	1TL8004-0EC42-1 □□□	960	84.5	83.6	0.70	2.85	10.9	6.1	2.1	2.8	0.00813	32	45/57
100L	1.5	0CV4104C8	1TL8004-1AC42-1 □□□	975	85.9	86.0	0.71	3.75	14.7	7.5	2.9	3.6	0.0188	49	49/61
112M	2.2	0CV4112C8	1TL8004-1BC22-1 □□□	965	87.4	87.8	0.71	5.4	21.8	7.5	3.6	3.8	0.024	55	53/65
132S	3	0CV4130C8	1TL8004-1CC02-1 □□□	982	88.6	88.9	0.71	7.2	29.2	8	2.7	3.5	0.048	67	57/69
1000rpm 6 极 6-pole															
380VD / 660VY 50HZ															
132M	4	0CV4132C8	1TL8004-1CC23-3 □□□	984	89.5	89.6	0.72	9.4	38.8	8	2.8	4	0.061	75	57/69
132M	5.5	0CV4133C8	1TL8004-1CC33-3 □□□	982	90.5	90.9	0.72	12.8	53.5	8	3.1	4	0.079	92	57/69
160M	7.5	0CV4162C8	1TL8004-1DC23-3 □□□	984	91.3	91.6	0.76	16.4	72.8	7.5	3	3	0.15	130	61/73
160L	11	0CV4164C8	1TL8004-1DC43-3 □□□	985	92.3	92.4	0.77	23.5	107	8	3.6	3.3	0.20	161	61/73
180L	15	0CV4184C8	1TL8004-1EC43-3 □□□	986	92.9	93.4	0.8	30.5	145	7.6	2.7	3	0.31	199	59/73
200L	18.5	0CV4204C8	1TL8004-2AC43-3 □□□	988	93.4	93.8	0.8	37.5	179	8	2.5	3	0.686	246	59/73
200L	22	0CV4205C8	1TL8004-2AC53-3 □□□	988	93.7	94.2	0.81	44	213	8	2.8	3	1.00	267	59/73
225M	30	0CV4222C8	1TL8004-2BC23-3 □□□	988	94.2	94.7	0.82	59	290	8.0	2.9	3.0	1.09	364	60/73
250M	37	0CV4252C8	1TL8004-2CC23-3 □□□	988	94.5	95.1	0.83	72	358	8.0	2.5	3.0	1.92	445	62/76
280S	45	0CV4280C8	1TL8004-2DC03-3 □□□	992	94.8	95.1	0.83	87	433	8.0	3.6	3.6	2.06	528	64/78
280M	55	0CV4282C8	1TL8004-2DC23-3 □□□	991	95.1	95.5	0.84	105	530	8.0	3.0	3.0	2.30	577	64/78
315S	75	0CV4310C8	1TL8004-3AC03-3 □□□	991	95.4	95.8	0.83	144	723	8.0	2.1	2.1	3.95	825	66/81
315M	90	0CV4312C8	1TL8004-3AC23-3 □□□	992	95.6	95.9	0.83	172	866	8.0	2.6	2.1	4.52	885	66/81
315L	110	0CV4315C8	1TL8004-3AC53-3 □□□	992	95.8	96.1	0.83	210	1059	8.0	2.8	2.3	5.02	965	66/81
315L	132	0CV4316C8	1TL8004-3AC63-3 □□□	992	96.0	96.2	0.82	255	1271	8.0	2.6	2.6	5.71	1030	66/81
355M	160	0CV4352C8	1TL8004-3BC23-3 □□□	993	96.2	96.5	0.84	300	1539	8.0	2.5	2.5	10.52	1610	76/91
355M	185	0CV4353C8	1TL8004-3BC33-3 □□□	993	96.3	96.6	0.84	345	1779	7.8	2.5	2.5	10.52	1630	76/91
355M	200	0CV4354C8	1TL8004-3BC43-3 □□□	992	96.3	96.6	0.84	375	1925	7.7	2.4	2.5	11.11	1680	76/91
355L	220	0CV4355C8	1TL8004-3BC53-3 □□□	994	96.4	96.6	0.84	415	2114	8.0	2.5	2.7	11.53	1760	76/91
355L	250	0CV4356C8	1TL8004-3BC63-3 □□□	993	96.5	96.7	0.84	470	2404	8.0	2.9	2.9	13.02	1880	76/91

注:

- 关于其他电压与频率、绕组保护及接线盒位置的编码, 请见“订货号”部分;
- 噪声值仅适用于电动机在 50 Hz 电源直接供电且空载运行时的情况, 容差为 +3 dB。

Note:

- About the code of other voltage and frequency, winding protection and connection box position, please refer to Orde No.
- Noise value is only applicable to the direct power supply of the motor in 50Hz power supply and the condition of no-load operation, the tolerance is +3dB.

选型技术数据表 Technical data table

铸铁壳系列电机 Cast Iron Motors

中国能效等级 2 级, IE4

机座号 Frame Size	额定 功率 Rate Output 50 Hz	电动机 型号 Motor type	订货号 Order No.	额定 转速 Rated Speed	效率 — 参照 GB18613-2020 效率等级 2 Efficiency is in accordance with the efficiency level 2 of GB18613-2020				额定 转矩 Rated torque	起动 电流 / 额定 电流 Starting current /Rated current	起动 转矩 / 额定 转矩 Starting torque/ Rated torque	最大 转矩 / 额定 转矩 Max torque / Rated torque	转动 惯量 Moment of Inertia	重量 IMB3 Weight	噪声 Noise
					效率 (100% 负载) Efficiency at (50 HZ) 4/4 load	效率 (75% 负载) Efficiency at (50 HZ) 3/4 load	功率 因数 Power factor	额定 电流 Rated current							
	kW	rpm	%	%		A	Nm	I_{LR}/I_{rated}	T_{LR}/T_{rated}	T_{max}/T_{rated}	kgm ²	kg	L_{pfa}/L_{VA}		
750rpm 8 极 8-pole															
220VD / 380VY 50HZ															
132S	2.2	0CV4130D8	1TL8004-1CD02-1 □□□□	725	84.5	85.1	0.7	5.7	29	6	2.2	2.8	0.052	69	51/64
132M	3	0CV4132D8	1TL8004-1CD22-1 □□□□	725	85.9	86.3	0.7	7.6	39.5	6.5	2.6	3.2	0.065	77	51/64
750rpm 8 极 8-pole															
380VD / 660VY 50HZ															
160M	4	0CV4162D8	1TL8004-1DD23-3 □□□□	736	87.1	87.4	0.71	9.8	51.9	6.5	2.5	2.5	0.13	119	55/68
160M	5.5	0CV4163D8	1TL8004-1DD33-3 □□□□	736	88.3	88.6	0.72	13.1	71.4	6.5	2.5	2.6	0.15	130	55/68
160L	7.5	0CV4164D8	1TL8004-1DD43-3 □□□□	734	89.3	89.8	0.74	17.2	97.6	6.5	2.5	2.5	0.18	152	55/68
180L	11	0CV4184D8	1TL8004-1ED43-3 □□□□	734	90.4	91.1	0.74	25	143	6	2	2.5	0.36	217	60/73
200L	15	0CV4205D8	1TL8004-2AD53-3 □□□□	736	91.2	92.0	0.75	33.5	195	7	2.8	3.2	1.00	265	61/74
225S	18.5	0CV4220D8	1TL8004-2BD03-3 □□□□	738	91.7	92.4	0.76	40.5	239	7	2.6	3	0.73	284	58/72
225M	22	0CV4222D8	1TL8004-2BD23-3 □□□□	737	92.1	92.8	0.76	48	285	7	2.7	3	0.83	313	58/72
250M	30	0CV4252D8	1TL8004-2CD23-3 □□□□	739	92.7	93.3	0.77	64	388	7.0	2.7	2.8	1.27	385	67/80
280S	37	0CV4280D8	1TL8004-2DD03-3 □□□□	740	93.1	93.6	0.78	77	478	7.0	2.4	2.6	1.65	472	69/82
280M	45	0CV4282D8	1TL8004-2DD23-3 □□□□	740	93.4	94.1	0.80	92	581	7.0	2.5	2.6	2.03	541	69/82
315S	55	0CV4310D8	1TL8004-3AD03-3 □□□□	738	93.7	94.7	0.80	111	712	7.7	1.8	2.0	3.62	805	73/88
315M	75	0CV4312D8	1TL8004-3AD23-3 □□□□	740	94.2	95.0	0.80	151	968	7.7	2.1	2.1	4.14	865	73/88
315L	90	0CV4315D8	1TL8004-3AD53-3 □□□□	741	94.4	95.1	0.81	179	1160	7.7	2.2	2.2	4.92	965	73/88
315L	110	0CV4316D8	1TL8004-3AD63-3 □□□□	742	94.7	95.2	0.81	220	1416	7.7	2.5	2.5	5.62	1040	73/88
355M	132	0CV4352D8	1TL8004-3BD23-3 □□□□	743	94.9	95.5	0.81	260	1697	7.7	2.2	2.2	9.67	1560	73/88
355M	160	0CV4353D8	1TL8004-3BD33-3 □□□□	743	95.1	95.7	0.82	310	2057	7.7	2.3	2.3	11.26	1690	73/88
355L	185	0CV4355D8	1TL8004-3BD53-3 □□□□	743	95.3	95.8	0.82	360	2378	7.7	2.3	2.3	11.87	1790	73/88
355L	200	0CV4356D8	1TL8004-3BD63-3 □□□□	744	95.4	95.9	0.82	390	2567	7.8	2.5	2.5	12.75	1870	73/88

注:

¹⁾ 关于其他电压与频率、绕组保护及接线盒位置的编码, 请见“订货号”部分;

²⁾ 噪声值仅适用于电动机在 50 Hz 电源直接供电且空载运行时的情况, 容差为 +3 dB。

Note:

¹⁾ About the code of other voltage and frequency, winding protection and connection box position, please refer to Orde No.

²⁾ Noise value is only applicable to the direct power supply of the motor in 50Hz power supply and the condition of no-load operation, the tolerance is +3dB.

选件 Options

电动机订货号 Motor order code	选件号 ¹⁾ Option Code	描述 Description	应用范围 Application Scope
电压与频率 Voltages and frequency			
1TL8004- □□□□ 9-0 □□□	M2A ²⁾¹⁵⁾	220VD/380VY 60Hz, 50Hz 功率输出 power output	FS80 ~ 355
	M2B ³⁾¹⁵⁾	380VD/660VY 60Hz, 50Hz 功率输出 power output	FS80 ~ 355
	M2C ²⁾¹⁵⁾	440VY 60Hz, 50Hz 功率输出 power output	FS80 ~ 355
	M2D ³⁾¹⁵⁾	440VD 60Hz, 50Hz 功率输出 power output	FS80 ~ 355
	M2E ²⁾¹⁵⁾	460VY 60Hz, 50Hz 功率输出 power output	FS80 ~ 280
	M2F ³⁾¹⁵⁾	460VD 60Hz, 50Hz 功率输出 power output	FS80 ~ 355
线圈和绝缘 Windings and insulation			
—	N01	温度等级 155 (F), 使用 155 (F), 带有服务系数 (SF1.15) Temperature class 155 (F), used according to 155 (F), with service factor (SF1.15)	FS80 ~ 355
—	N10	180 (H) 度温度等级绝缘 Temperature class 180 (H)	FS80 ~ 355
—	Q04 ⁴⁾	绕组带 220 V 防潮加热带 Anti-condensation heater for 220 VAC (spaces heater)	FS80 ~ 355
电动机接线盒 Motor connection box			
—	R10 ⁵⁾	接线盒直接旋转 90°, 进线口朝向驱动端 Rotation of the connection box through 90°, entry from DE	FS80 ~ 355
—	R11	接线盒直接旋转 90°, 进线口朝向非驱动端 Rotation of the connection box through 90°, entry from NDE	FS80 ~ 355
—	R12	接线盒直接旋转 180° Rotation of the connection box through 180°	FS80 ~ 355
—	H04	外部接地 external earthing	FS80 ~ 355
—	X07	铸铁接线盒 cast iron connection box	FS80 ~ 355
—	X47	电机接线盒标配 2 个自锁葛兰 Connection boxes of the motors include 2 self-locking cable gland	FS100 ~ 355

1) 订货时, 电动机订货号需带“-Z”, 另外附上选件号;

2) 一般适用于 3kW 及以下功率的电机;

3) 一般适用于 3kW 以上功率的电机;

4) 选择此选件, 接线盒将更改为铸铁壳;

5) 不适用 FS80 ~ 112 法兰安装电机;

6) 铸铁机座电机不含 160 机座号;

7) H00、F70 均不能与此选件并用;

8) 非驱动端上的第二轴伸尺寸见外形尺寸;

1) Order No. supplement Z with option code when ordering.

2) Only applicable to the motor whose power is 3kW and below.

3) Only applicable to the motor whose power is 3kW and above.

4) When choose these options, the connection boxes will be changed to cast iron shell.

5) Not applicable to the FS80 ~ 112 flange mounted motors.

6) Cast iron motor exclude FS160.

7) H00、F70 can't be used with this option.

8) Second standard shaft extension on NDE is shown in the dimension drawings.

选件 Options

电动机订货号 Motor order code	选件号 ¹⁾ Option Code	描述 Description	应用范围 Application Scope
轴承 Bearings			
—	Q72	轴承带两个 PT100 测温元件 Installation of 2PT100 screw-in resistance thermometers for bearing	FS180 ~ 355
—	L80	SKF 轴承 SKF Bearing	FS80 ~ 355
—	L81	其他进口品牌轴承 Other imported brand bearings	FS80 ~ 355
—	L20 ¹⁶⁾	驱动端轴承固定 Located bearing at DE	FS80 ~ 160
—	L22 ⁶⁾¹⁶⁾	增强悬臂力 Increased cantilever forces	FS100 ~ 355
—	L51 ¹⁸⁾	非驱动端轴承绝缘 Bearing insulation NDE	FS250 ~ 355
机械设计和防护等级 Mechanical design and degrees of protection			
—	L04	光轴设计，不带键槽和键 Shaft without key and keyway	FS80 ~ 355
—	L72 ⁷⁾⁸⁾	第二标准轴伸 Second standard shaft extension	FS80 ~ 355
—	P80 ⁹⁾	全圆法兰 Full circle flange	FS80 ~ 355
—	H22	IP56 防护等级（非高海况） IP56 degree of protection (non-heavy-sea)	FS80 ~ 355
—	H20	IP65 防护等级（非高海况） IP65 degree of protection (non-heavy-sea)	FS80 ~ 355
—	H00 ¹⁰⁾	电动机带防护罩 Motor with protective cover	FS80 ~ 355

⁹⁾ 对于机座号为 180, 200, 225 和 280 的电动机不适用，这些机座号的电动机标配的法兰为全圆法兰；

¹⁰⁾ 无法与选件号 L72 并用；

¹¹⁾ 仅适用于水平安装的电动机。对于 IM B5 和 IM B14 安装结构型式的电动机，选择此选件时，必须确保接线盒处于机座顶端。对于其它安装结构型式的电机请咨询茵梦达；

¹²⁾ 无风扇和风罩时，电动机的长度将减小 Δl 。如需要按照铭牌上功率数值输出时电动机需要外部冷却。客户应当采用正确的冷却方式，没有或错误的冷却方式都将减少电动机的使用寿命，甚至会损坏电动机；

¹³⁾ SINAMICS 变频器联结 Omron 编码器（E6B2-CWZ6C）时，变频器需要一些特殊配置。详细信息，请咨询茵梦达热线；

⁹⁾ Not applicable to the FS180,200,225,280 motors, these motors include the full circle flange.

¹⁰⁾ Unable to be used with the option L72.

¹¹⁾ Only applicable to the vertical mounting motors. For the construction type of IM B5 and IM B14, when choose this option, it is necessary to ensure the connection box is on top of the frame. For other construction types, please specially consult with INNOMOTICS.

¹²⁾ When without the fans or the shells, the motor length will be decreased by Δl . If it is necessary to output according to the nameplate power, the motor requires external cooling. Customers are supposed to adopt the right cooling method, without or wrong cooling methods will decrease the service life for the motors. even damage the motors.

¹³⁾ When the SINAMICS frequency converter is coupled with the Omron encoder (E6B2-CWZ6C), the frequency converter requires some special configuration. For more information, please consult the INNOMOTICS hotline.

选件 Options

电动机订货号 Motor order code	选件号 ¹⁾ Option Code	描述 Description	应用范围 Application Scope
—	H03 ¹¹⁾	排水孔 Drainage holes	FS80 ~ 355
—	F90 ¹²⁾	风机电机（无风扇风罩，非驱动端全封闭） Fan motor(no fan cover, NDE fully enclosed)	FS80 ~ 355
—	D03	用于环境温度 -40 °C ~ +40 °C 下使用的电机 Applicable to the motors that is used in the coolant temperature of -40°C~+40°C	FS80 ~ 355
—	X50 ¹³⁾	安装欧姆龙编码器（E6B2-CWZ6C-1024）和独立驱动风扇 Install OMRON encoder (E6B2-CWZ6C-1024) and independent drive fan	FS80 ~ 355
—	X59	预留安装 E6B2-C/TRD-2T 编码器位置并安装独立驱动风扇 Prepared for of E6B2-C/TRD-2T encoder and install independent drive fan	FS100 ~ 355
—	F01 ¹⁷⁾	安装电磁制动器 Install the electro-magnetic brake	FS80 ~ 225
—	W74 ¹⁴⁾	安装欧姆龙编码器（E6B2-CWZ1X-1024）和独立驱动风扇 Install the OMRON encoder(E6B2-CWZ1X-1024) and independent drive fan	FS80 ~ 355
—	F70 ¹⁰⁾	电动机带独立驱动风扇 Motors with the independent drive fan	FS80 ~ 355
铭牌和测试证书 Rating plate and test certificates			
—	B80	出厂检验报告 Acceptance test certificate 3.1 in accordance with EN 10204	FS80 ~ 355
—	W9P	能效标签及合格证不贴，随机带走 CEL label and quality certificate not pasted,delivered with motors	FS80 ~ 355

¹⁴⁾ SINAMICS 变频器可以直接与 Omron 编码器（E6B2-CWZ1X）联结。

¹⁵⁾ 根据国标要求，60Hz 频率下不考核能效要求。

¹⁶⁾ FS 180-355, L20 与 L22 不能同时选用。

¹⁷⁾ 此制动器不可与 X50, X59 及 W74 中的编码器同时选用。若电机输入变频电源，整流器需单独接工频电源。请在配置该选件时注明电机变频使用。接线盒将单独为整流器引线配置进线葛兰孔，详细信息，请咨询茵梦达热线。

¹⁸⁾ L51 在 280 机座，非驱动端轴承型号为 6316，在 355 机座 4/6/8 极，非驱动端轴承型号将变为 6320。

¹⁴⁾ SINAMICS frequency converter can be directly coupled with the Omron encoder (E6B2-CWZ1X).

¹⁵⁾ According to the requirements of the GB, the energy efficiency requirement is not evaluated under the frequency of 60Hz.

¹⁶⁾ For FS 180-355, L20+L22 can't be selected.

¹⁷⁾ This type electro-magnetic brake can't be configure together with pulse encode in option X50, X59 and W74. In VSD application, rectifier should connect to DOL course separately. Please give indication of VSD application when selecting this option. There will be a separate cable gland for rectifier. For details please contact Innomatics.

¹⁸⁾ L51 NDE bearing is 6316 on FS280, 6320 on FS355 4/6/8 poles.

选件 Options

电动机订货号 Motor order code	选件号 ¹⁾ Option Code	描述 Description	应用范围 Application Scope
喷漆 Paint finish			
—	S01	不喷漆，只带底漆 Unpainted, only primed	FS80 ~ 355
—	W88	适用 TH, W, F1, WF1 以及海洋性气候环境用电机 Design for TH, W, F1, WF1 and Sea air resistant	FS80 ~ 355
包装 Packing			
—	B90	包装 (FS80 ~ 132 电动机采用纸箱包装, FS160 ~ 355 电动机采用木箱包装) Packing (FS80 ~ 132 motors adopt the carton packaging, FS160 ~ 355 motors adopt the wooden cases packaging)	FS80 ~ 355
—	V9N	法兰安装电机用简易托盘 Simple tray for flange mounted motors	FS160 ~ 355

外形尺寸 Dimension drawings

1TL8004 铸铁系列电机 Cast-iron series 1TL8004

IM B3 安装结构方式 Type of construction IM B3

机座号从 80-90 Frame sizes 80-90

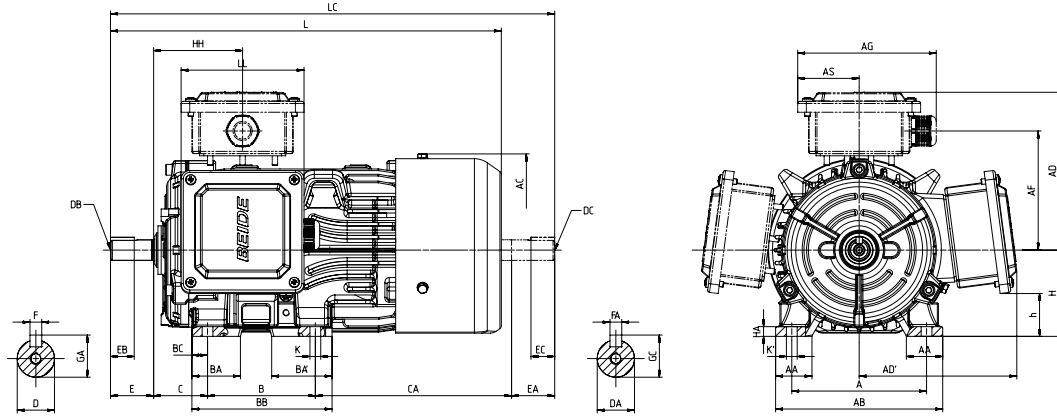

机座号从 100-280 Frame sizes 100-280

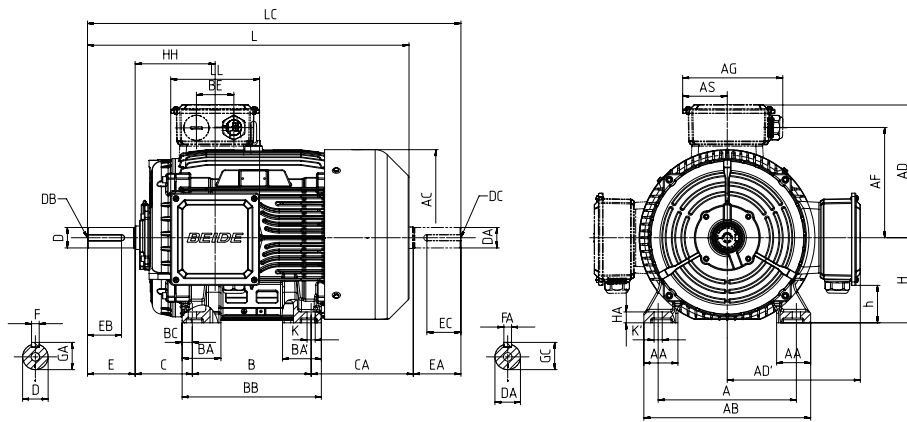

机座号 Frame size	类型 Type 1TL8004-	极数 Poles	尺寸图依据 IEC 标准 Dimension designation according to IEC standards																							
			A	AA	AB	AC ¹⁾	AD/AD'	AF/AF'	AG	AH	AS	B ²⁾	BB	BC	BE	C ³⁾	CA ²⁾	H	h	HD	HA	HH	K/K'	L	LC	LL
80M	0D□2	2,4	125	33.5	155	179	150	110.5	134	204	57	100	130	14.5	-	50	182	80	39	-	9	82.5	10	370	440	114
	0D□3	2,4,6																								
90S	0E□0	2,4,6	140	33.5	170	191	160	117	134	220	57	100	128	12.5	-	56	196	90	51	-	10	91	10	400	455	114
	0E□4																211							440	495	
100L	1A□4	2,4,6	160	45	196	227	187	144	148	-	59.5	140	200	16	46	63	247	100	40.5	-	12	100	12	505	570	128
	1A□5	4	160	45	196	227	187	144	148	-	59.5	140	200	16	46	63	247	100	40.5	-	12	100	12	505	570	128
112M	1B□2	2,4,6	190	45	226	247	203/190	155.5/148	148	-	59.5	140	174	16	46	70	222	112	58	-	12	106	12	490	552	128
132S	1C□0	2	216	50	256	290	215	171	147.5	390	59.5	140	180	20	46	89	218	132	72.5	-	15	111.5	12	515	600	128
	1C□1	4,6,8	216	50	256	290	215	171	147.5	390	59.5	140	180	20	46	89	218	132	72.5	-	15	111.5	12	515	600	128
132M	1C□2	4,6,8	216	50	256	290	215	171	147.5	390	59.5	178	218	20	46	89	218	132	72.5	-	15	111.5	12	560	645	128
	1C□3		216	50	256	290	215	171	147.5	390	59.5	178	218	20	46	89	218	132	72.5	-	15	111.5	12	560	645	128
160M	1D□2	2,4,6,8	254	60	300	348	255	205	178	470	77	210	253	20	56	108	237	160	83	-	18	148	15	655	755	149
	1D□3	2,8	254	60	300	348	255	205	178	470	77	210	253	20	56	108	237	160	83	-	18	148	15	655	755	149
160L	1D□4	2,4,6,8	254	60	300	348	255	205	178	470	77	254	297	20	56	108	225	160	83	-	18	148	15	690	807	149
180M	1E□2	2,4	279	60	339	395	275	230	178	500	77	241	291	25	56	121	298	180	103	-	20	154	15	765	880	149
180L	1E□4	4,6,8	279	60	339	395	275	230	178	500	77	279	329	25	56	121	270	180	103	-	20	154	15	780	890	149
200L	2A□4	2,6	318	70	378	438	330	265	266	570	110.5	305	355	25	87	133	282	200	85.5	-	25	194	19	825	940	221
	2A□5	2,4,6,8	318	70	378	438	330	265	266	570	110.5	305	355	25	87	133	282	200	85.5	-	25	194	19	825	940	221
225S	2B□0	4,8	356	80	436	479	355	290	266	630	110.5	311	361	25	87	149	300	225	100.5	-	34	191	19	870	1015	221
225M	2B□2	2	356	80	436	479	355	290	266	630	110.5	311	361	25	87	149	325	225	100.5	-	34	191	19	890	1005	221
		4,6,8	356	80	436	479	355	290	266	630	110.5	311	361	25	87	149	325	225	100.5	-	34	191	19	920	1065	221

1) 包含螺栓头的尺寸。 2) 该尺寸为 DIN EN 50347 标准所列机座号对应尺寸。
3) 当特殊设计为接线盒在非驱动端时，电机安装等相关尺寸会发生变化，具体请咨询茵梦达。

机座号从 315-355 Frame sizes 315-355

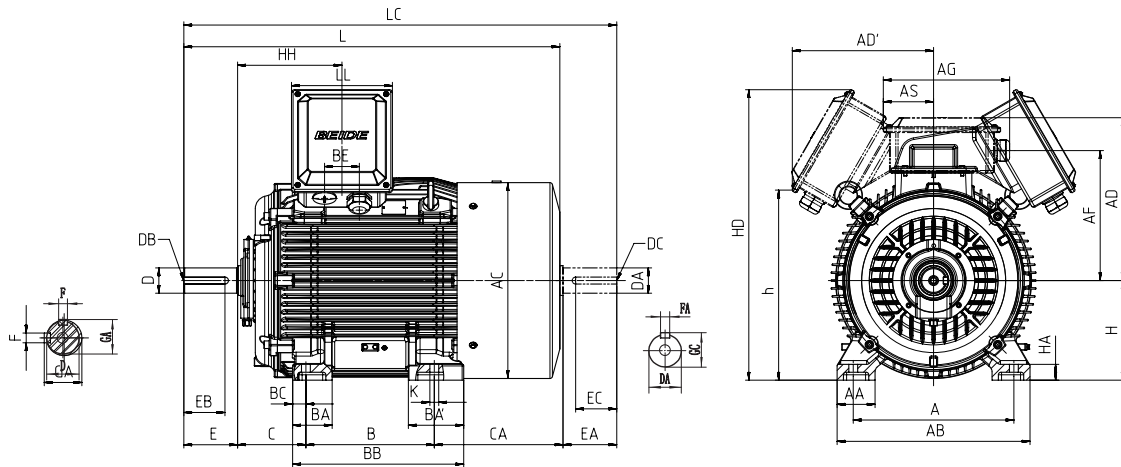

IM B5 以及 IM V1 安装方式 Type of construction IM B5 and IM V1
机座号从 80-90 Frame size 80-90

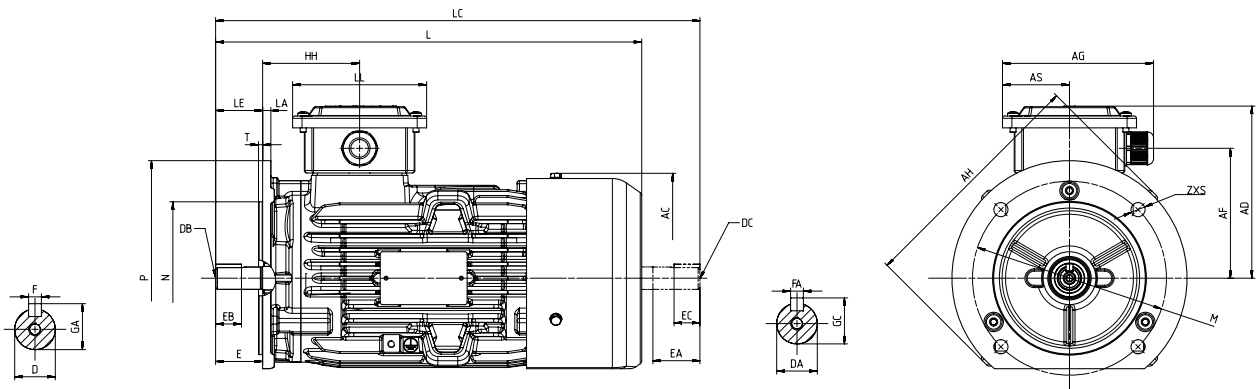

机座号 Frame size	类型 Type 1TL8004-	极数 Poles	驱动端轴伸直径 DE shaft extension							非驱动端轴伸 (选项号为 L72) NDE shaft extension (option code L72)					
			D	DB	E	EB	F	GA	DA	EA	EC	FA	GC (顶针孔)	DC (顶针孔)	
80M	0D□2	2,4	19	M6x16	40	22	6	21.5	19	40	22	6	21.5	M6x16	
	0D□3	2,4,6													
90S	0E□0	2,4,6	24	M8x19	50	32	8	27	24	50	32	8	27	M8x19	
90L	0E□4														
100L	1A□4	2,4,6	28	M10x22	60	40	8	31	28	60	40	8	31	M10x22	
	1A□5	4	28	M10x22	60	40	8	31	28	60	40	8	31	M10x22	
112M	1B□2	2,4,6	28	M10x22	60	40	8	31	28	60	40	8	31	M10x22	
132S	1C□0	2	38	M12x28	80	56	10	41	38	80	56	10	41	M12x28	
	1C□1	4,6,8	38	M12x28	80	56	10	41	38	80	56	10	41	M12x28	
132M	1C□2	4,6,8	38	M12x28	80	56	10	41	38	80	56	10	41	M12x28	
	1C□3		38	M12x28	80	56	10	41	38	80	56	10	41	M12x28	
160M	1D□2	2,4,6,8	42	M16x36	110	80	12	45	42	110	80	12	45	M16x36	
	1D□3	2,8	42	M16x36	110	80	12	45	42	110	80	12	45	M16x36	
160L	1D□4	2,4,6,8	42	M16x36	110	80	12	45	42	110	80	12	45	M16x36	
180M	1E□2	2,4	48	M16x36	110	80	14	51.5	48	110	80	14	51.5	M16x36	
180L	1E□4	4,6,8	48	M16x36	110	80	14	51.5	48	110	80	14	51.5	M16x36	
200L	2A□4	2,6	55	M20x42	110	88	16	59	55	110	88	16	59	M20x42	
	2A□5	2,4,6,8	55	M20x42	110	88	16	59	55	110	88	16	59	M20x42	
225S	2B□0	4,8	60	M20x42	140	100	18	64	60	140	100	18	64	M20x42	
225M	2B□2	2	55	M20x42	110	80	16	59	55	110	80	16	59	M20x42	
		4,6,8	60	M20x42	140	100	18	64	60	140	100	18	64	M20x42	

1) Measured across the bolt heads. 2) This dimension is assigned in DIN EN 50347 to the frame size listed.
3) When terminal box special designed at the non drive end, the dimension related to motor installation may change, for more information, please consult the INNOMOTICS.

外形尺寸 Dimension drawings

机座号从 100-355 Frame size 100-355

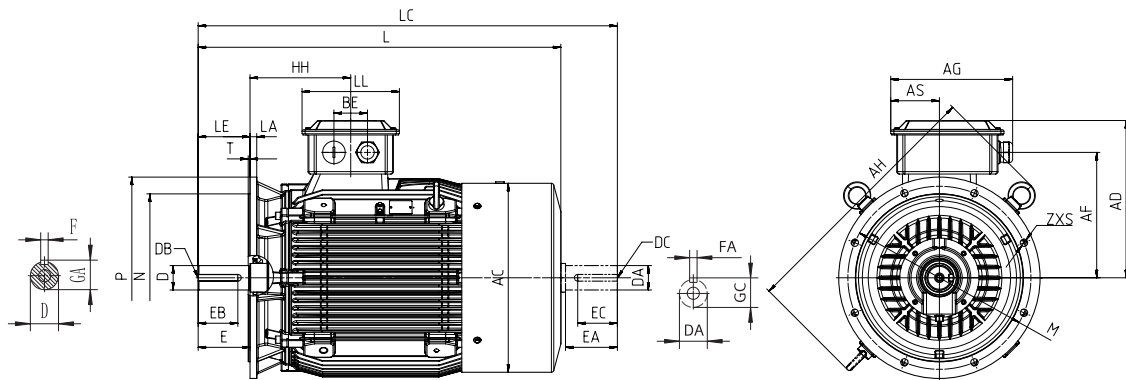

IM B35 安装结构方式 Type of construction IM B35

机座号从 80-90 Frame sizes 80-90

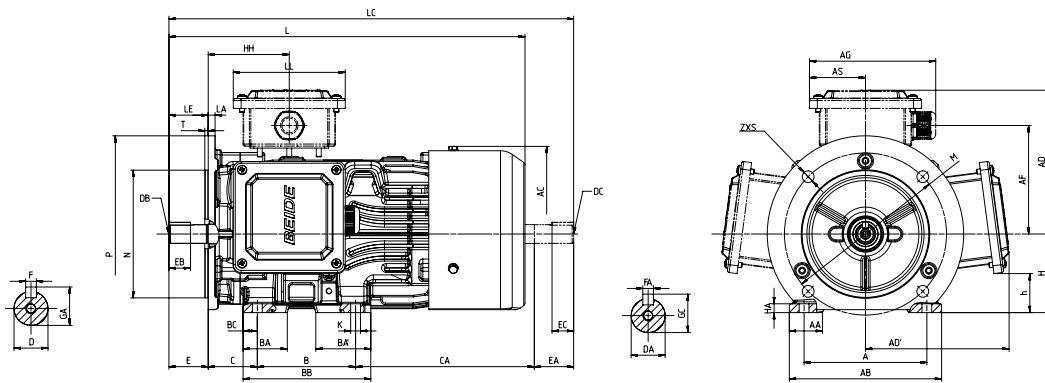

机座号 Frame size	类型 Type 1TL8004- size	极数 Poles	尺寸图依据 IEC 标准 Dimension designation according to IEC standards																									
			A	AA	AB	AC ¹⁾	AD/AD'	AF/AF'	AG	AH	AS	B ²⁾	BB	BC	BE	C ³⁾	CA ²⁾	H	h	HD	HA	HH	K/K'	L	LC	LL		
250M	2C□2	2	406	100	490	524	395	324	294	690	131	349	409	30	110	168	300	250	105	-	32	235	24	950	1100	261		
		4,6,8	406	100	490	524	395	324	294	690	131	349	409	30	110	168	300	250	105	-	32	235	24	950	1100	261		
280S	2D□0	2	457	100	540	565	405	335	294	735	131	368	428	30	110	190	302	280	115	-	40	224	24	990	1140	261		
		4,6,8	457	100	540	565	405	335	294	735	131	368	428	30	110	190	302	280	115	-	40	224	24	990	1140	261		
280M	2D□2	2	457	100	540	565	405	335	294	735	131	419	479	30	110	190	306	280	115	-	40	224	24	1045	1195	261		
		4,6,8	457	100	540	565	405	335	294	735	131	419	479	30	110	190	306	280	115	-	40	224	24	1045	1195	261		
315S	3A□0	2	508	120	610	640	520/450	411	400	860	160	406	541	42	110	216	413	315	601	925	50	330	28	1165	1315	320		
		4,6,8	508	120	610	640	520/450	411	400	860	160	406	541	42	110	216	413	315	601	925	50	330	28	1165	1315	320		
315M	3A□2	2	508	120	610	640	520/450	411	400	860	160	457	541	42	110	216	362	315	601	925	50	330	28	1165	1315	320		
		4,6,8	508	120	610	640	520/450	411	400	860	160	457	541	42	110	216	362	315	601	925	50	330	28	1165	1315	320		
315L	3A□5 3A□6/3A□7 3A□5/3A□6/3A□7	2	508	120	610	640	520/450	411	400	860	160	508	592	42	110	216	361	315	601	925	50	330	28	1215	1365	320		
		2															456								1310	1460		
		4															456									1340	1520	
		6,8															361									1245	1425	
355M	3B□2	2	610	120	730	712	615/495	504	457	975	185	560	696	68	125	254	506	355	731	1080	53	322	28	1450	1600	370		
		4,6,8	610	120	730	712	615/495	504	457	975	185	560	696	68	125	254	506	355	731	1080	53	322	28	1480	1660			
		2	610	120	730	712	615/495	504	457	975	185	560	696	68	125	254	506	355	731	1080	53	322	28	1450	1600	370		
355L	3B□3	2	610	120	730	712	615/495	504	457	975	185	560	696	68	125	254	506	355	731	1080	53	322	28	1480	1660			
		4,6,8	610	120	730	712	615/495	504	457	975	185	560	696	68	125	254	506	355	731	1080	53	322	28	1480	1660			
		6	610	120	730	712	615/495	504	457	975	185	560	696	68	125	254	506	355	731	1080	53	322	28	1480	1660	370		
355L	3B□4	2	610	120	730	712	615/495	504	457	975	185	630	750	68	125	254	516	355	731	1080	53	322	28	1530	1680	370		
		4,6,8	610	120	730	712	615/495	504	457	975	185	630	750	68	125	254	516	355	731	1080	53	322	28	1560	1740			
		2	610	120	730	712	615/495	504	457	975	185	630	750	68	125	254	516	355	731	1080	53	322	28	1530	1680	370		
355L	3B□6	2	610	120	730	712	615/495	504	457	975	185	630	750	68	125	254	516	355	731	1080	53	322	28	1560	1740			
		4,6,8	610	120	730	712	615/495	504	457	975	185	630	750	68	125	254	516	355	731	1080	53	322	28	1560	1740			

1) 包含螺栓头的尺寸。 2) 该尺寸为 DIN EN 50347 标准所列机座号对应尺寸。
3) 当特殊设计为接线盒在非驱动端时, 电机安装等相关尺寸会发生变化, 具体请咨询茵梦达。

机座号从 100-355 Frame sizes 100-355

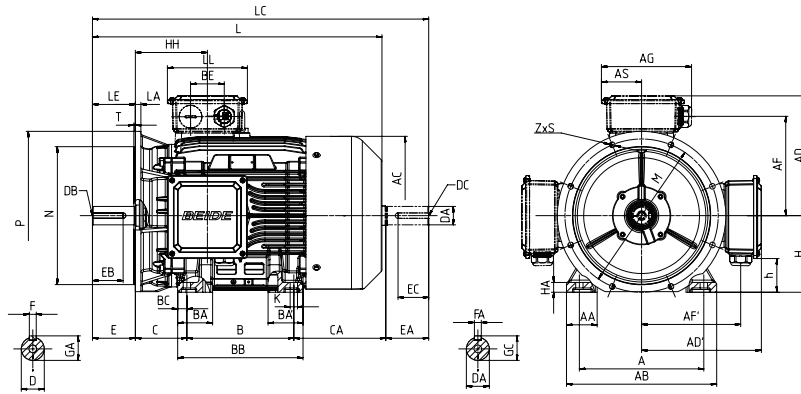

机座号 Frame size	类型 Type 1TL8004-	极数 Poles	驱动端轴伸直径 DE shaft extension						非驱动端轴伸 (选项号为 L72) NDE shaft extension (option code L72)					
			D	DB	E	EB	F	GA	DA	EA	EC	FA	GC	DC (顶针孔)
250M	2C□2	2	60	M20x42	140	100	18	64	60	140	100	18	64	M20x42
		4,6,8	65	M20x42	140	100	18	69	65	140	100	18	69	M20x42
280S	2D□0	2	65	M20x42	140	100	18	69	65	140	100	18	69	M20x42
		4,6,8	75	M20x42	140	100	20	79.5	75	140	100	20	79.5	M20x42
280M	2D□2	2	65	M20x42	140	100	18	69	65	140	100	18	69	M20x42
		4,6,8	75	M20x42	140	100	20	79.5	75	140	100	20	79.5	M20x42
315S	3A□0	2	65	M20x42	140	100	18	69	65	140	100	18	69	M20x42
		4,6,8	80		170	130	22	85	80	170	130	22	85	
315M	3A□2	2	65	M20x42	140	100	18	69	65	140	100	18	69	M20x42
		4,6,8	80		170	130	22	85	80	170	130	22	85	
315L	3A□5 3A□6/3A□7 3A□5/3A□6/3A□7	2	65	M20x42	140	100	18	69	65	140	100	18	69	M20x42
		2	65		140	100	18	69	65	140	100	18	69	
		4	80		170	130	22	85	80	170	130	22	85	
		6,8	80		170	130	22	85	80	170	130	22	85	
355M	3B□2	2	75	M20x42	140	100	20	79.5	75	140	100	20	79.5	M20x42
		4,6,8	95	M24x50	170	130	25	100	95	170	130	25	100	M24x50
	3B□3	2	75	M20x42	140	100	20	79.5	75	140	100	20	79.5	M20x42
		4,6,8	95	M24x50	170	130	25	100	95	170	130	25	100	M24x50
	3B□4	6	95	M24x50	170	130	25	100	95	170	130	25	100	M24x50
355L	3B□5	2	75	M20x42	140	100	20	79.5	75	140	100	20	79.5	M20x42
		4,6,8	95	M24x50	170	130	25	100	95	170	130	25	100	M24x50
	3B□6	2	75	M20x42	140	100	20	79.5	75	140	100	20	79.5	M20x42
		4,6,8	95	M24x50	170	130	25	100	95	170	130	25	100	M24x50

1) Measured across the bolt heads. 2) This dimension is assigned in DIN EN 50347 to the frame size listed.
3) When terminal box special designed at the non drive end, the dimension related to motor installation may change, for more information, please consult the INNOMOTICS.

外形尺寸 Dimension drawings

法兰尺寸 Flange dimension

IM B5、IM B35、IM V1、IM V3 安装结构型式 Type of construction IM B5, IM B35, IM V1, IM V3

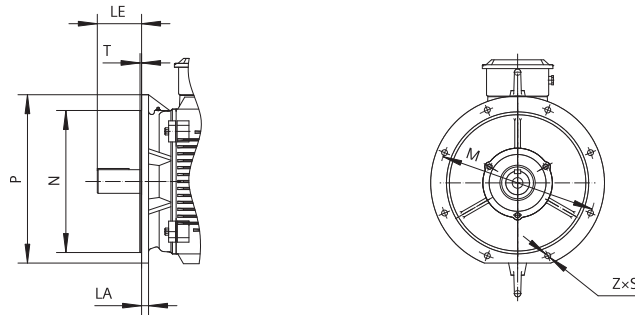

机座号 Frame size	安装结构形式 Type of construction	法兰带通孔 (FF / A) / 法兰带内螺纹孔 (FT / C) Flange with through holes (FF/A) / tapped holes (FT/C)
		按 DIN / EN 50 347 标准 According to DIN EN 50347
80	IM B5, IM B35, IMV1, IM V3 IM B14, IM V18, IM V19	FF165 FT100
90	IM B5, IM B35, IMV1, IM V3 IM B14, IM V18, IM V19	FF165 FT115
100	IM B5, IM B35, IMV1, IM V3 IM B14, IM V18, IM V19	FF215 FT130
112	IM B5, IM B35, IMV1, IM V3 IM B14, IM V18, IM V19	FF215 FT130
132	IM B5, IM B35, IMV1, IM V3	FF265
160	IM B5, IM B35, IMV1, IM V3	FF300
180	IM B5, IM B35, IMV1, IM V3	FF300
200	IM B5, IM B35, IMV1, IM V3	FF350
225	IM B5, IM B35, IMV1, IM V3	FF400
250	IM B5, IM B35, IMV1, IM V3	FF500
280	IM B5, IM B35, IMV1, IM V3	FF500
315	IM B5, IM B35, IMV1, IM V3	FF600
355	IM B5, IM B35, IMV1, IM V3	FF740

法兰尺寸 Flange dimension

IM B14、IM V18、IM V19 安装结构型式 Type of construction IM B14, IM V18, IM V19

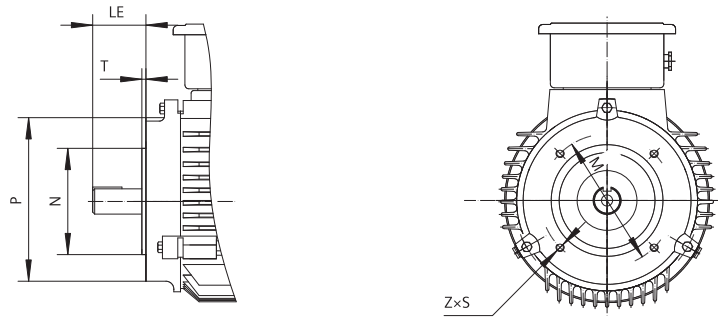

机座号 Frame size	尺寸图依据 Dimension designation according to IEC standards							
	LA	LE	M	N	P	S	T	Z
80	10 —	40 40	165 100	130 80	200 120	12 M6	3,5 3	4 4
90	10 —	50 50	165 115	130 95	200 140	12 M8	3,5 3	4 4
100	11 -	60 60	215 130	180 110	250 160	14,5 M8	4 3,5	4 4
112	11 -	60 60	215 130	180 110	250 160	14,5 M8	4 3,5	4 4
132	12	80	265	230	300	14,5	4	4
160	13	110	300	250	350	18,5	5	4
180	13	110	300	250	350	18,5	5	4
200	15	110	350	300	400	18,5	5	4
225	16	110/140	400	350	450	18,5	5	8
250	18	140	500	450	550	18,5	5	8
280	18	140	500	450	550	18,5	5	8
315	22	140/170	600	550	660	24	6	8
355	25	140/170	740	680	800	24	6	8

茵梦达电机（中国）有限公司

地址：江苏省仪征市汽车工业园众鑫路99号

电话：+86 514 85718108

传真：+86 514 85718083

邮编：211400

邮箱：motorservice.ssml.cn@innomotics.com

网址：www.beide-motor.cn

茵梦达电机（中国）有限公司版权所有，如有改动恕不事先通知。