

1TL0001 铸铁系列低压三相异步电动机
1TL0001 Cast Iron series Low-voltage
Three-phase Asynchronous Motor

产品样本 Catalog
2026. 02

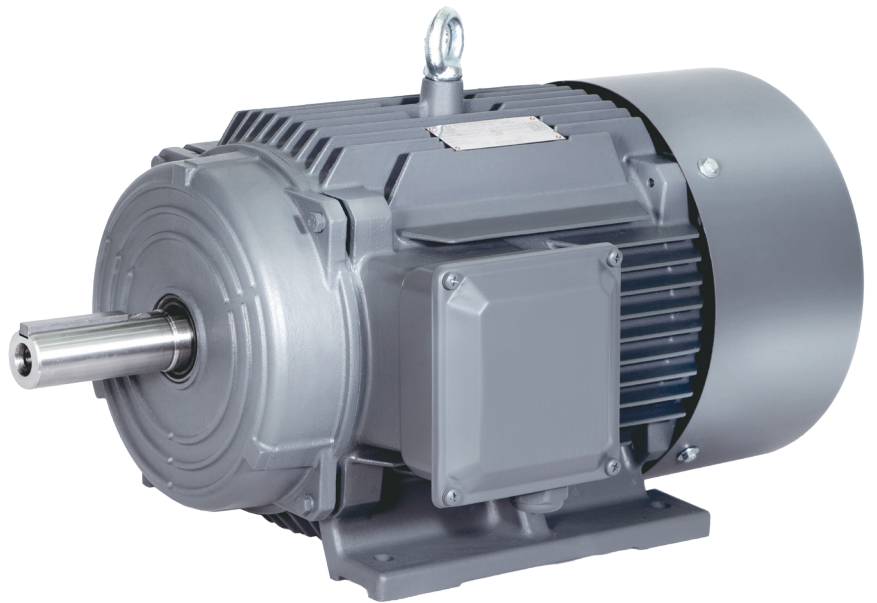

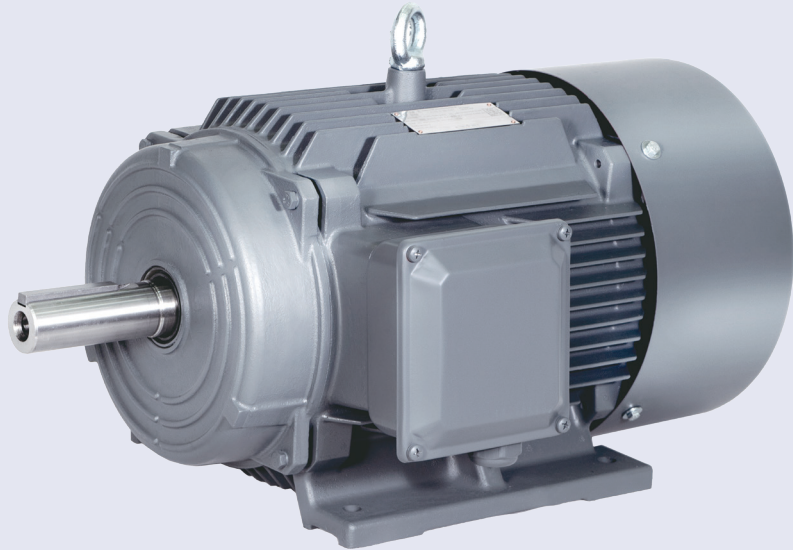

为更好应对气候变化，快速响应市场需求，聚焦提升能效与可靠性的创新，推动产业绿色低碳转型和可持续发展。2023年7月1日，西门子将其低压至高压电机、齿轮电机、中压变频器 and 电主轴领域等相关业务进行整合，成立了茵梦达（Innomotics GmbH）。茵梦达总部位于德国纽伦堡，业务遍及全球49个国家，拥有16家工厂，全球员工约15000名。

凭借百余年技术积淀和创新，茵梦达将专注于电机和大型传动专业领域。作为行业领军企业，茵梦达将不断推动工业化进程和可持续发展。

茵梦达在华拥有5家运营公司（包括一家区域总部和4家工厂），13家分公司和6家研发中心，其中在南京设立了“茵梦达低压电机事业部全球研发中心”，员工总数约3500人，是茵梦达在全球主要的研发和制造基地。



茵梦达电机（中国）有限公司原名西门子电机（中国）有限公司，于2006年3月1日正式运营，2024年5月正式更名。

从2018年荣获国家绿色工厂，到2019年被认定为国家高新技术企业，再到累计五次荣获西门子中国最佳运营工厂殊荣，茵梦达电机（中国）有限公司一直致力于为客户提供创新、高效、可持续的电机解决方案。

公司拥有员工约2000余人，占地面积18.2万平方米，年产电机约100万台，为茵梦达在华最大的低压、高效电机研发和生产基地。

目录 Contents

概述	
Overview	5
变频应用	
Converter fed application	11
订货号	
Order No.	13
选型技术数据表	
Technical data table	15
选件	
Options	19
外形尺寸	
Dimension drawings	22

概述 Overview

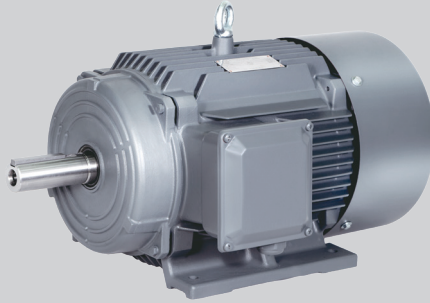

铸铁壳电机 Cast iron housing motor

额定功率：0.55 ~ 315 kW

机座号：80 ~ 355

电压与频率：支持多种电压与频率

冷却方式：IC411

注油装置：机座号 180 ~ 355 的电机标配

防护等级：IP55

绝缘等级：F

环境温度：-15 ~ 40 °C

海拔高度：不超过 1000 m

Rated output: 0.55 ~ 315 kW

Frame size: 80 ~ 355

Voltage and Frequency: support multiple voltage and frequency

Cooling method: IC411

Oiling device: FS180~355 motor as standard

Degree of protection: IP55

Degree of insulation: F

















Coolant temperature: -15 ~ 40 °C

Site altitude above sea level: not exceed 1000 m

1TL0 系列电动机具有效率高、结构新颖、造型美观、噪音低、振动小、绝缘等级高等特点，可用于风机、泵、压缩机、纺织机械等多种工业应用领域。此样本中内容仅适用于连续工作制（S1）、IC416 或 IC418 或者 60 Hz 运行的恒转速或一定速度范围内的变频调速应用。

1TL0 series of motors owns the features of high efficiency, novel structure, beautiful appearance, low noise, small vibration, high degree of insulation, etc, also can be used in the fields of fans, pump, compressors and textile machine. The content in this catalogue only be suitable for continuous duty operation(S1), IC416 or IC418 cooling method or under 60Hz.

安装结构型式 Construction and mounting type

结构型式 Construction type	机座带底脚，端盖无法兰 With feet and without flange on the end-shield (DE)					
安装型式 Mounting type	IM B3 FS ³⁾ 80 ~ 355	IM B6 FS 80 ~ 160	IM B7 FS80 ~ 160	IM B8 FS 80 ~ 160	IM V5 ¹⁾ FS 80 ~ 160	IM V6 ²⁾ FS 80 ~ 160
示意图 Diagram						
电动机订货号第 14 位 号上对应的字母 Letter, position 14 th of Motor code	A	T	U	V	C	D
结构型式 Construction type	机座不带底脚，端盖有法兰 Without feet and with flange on the end-shield (DE)			机座带底脚，端盖有法兰 With feet and with flange on the end-shield (DE)		
安装型式 Mounting type	IM B5 FS 80 ~ 280	IM V1 ^{1) 3)} FS 80 ~ 355	IM V3 ^{2) 3)} FS 80 ~ 160	IM B35 FS 80 ~ 355	IM V15 ¹⁾ FS 80 ~ 160	IM V35 ²⁾ FS 80 ~ 160
示意图 Diagram						
电动机订货号第 14 位 号上对应的字母 Letter, position 14 th of Motor code	F	G	H	J	W	Y
结构型式 Construction type	机座不带底脚，端盖有标准小法兰 Without feet and with C-flange on the end-shield (DE)			机座带底脚，端盖有标准小法兰 With feet and with C-flange on the end-shield (DE)		
安装型式 Mounting type	IM B14 FS 80 ~ 112	IM V18 ¹⁾ FS 80 ~ 112	IM V19 ²⁾ FS 80 ~ 112	IM B34 FS80 ~ 112		
示意图 Diagram						
电动机订货号第 14 位 号上对应的字母 Letter, position 14 th of Motor code	K	M	L	N		

¹⁾ 室外使用时推荐使用护罩（选件号 H00）；

²⁾ 当户外安装时，推荐对电动机轴采取防护措施，避免水直接喷射到电动机轴上。

³⁾ 此安装方式中，标配全圆法兰。

¹⁾ At outdoor application, the using of protective cover (Option code H00) is recommended

²⁾ At out door application the protection of shaft again jet-water is recommended

³⁾ Full circle flange as standard configuration in this type mounting.

铭牌样例 Nameplate

1TL0001 系列电机铭牌

1TL0001 Motor Nameplate

 THREE-PHASE ASYNCHRONOUS MOTOR 三相异步电动机	
型号 1TL0001-3BA2 3-3AA5-Z	355M IMB3 LMH-2406/800003888993/002
380V△/660VY	50 Hz 390/225 A EFF. 95.0 % IP 55 Q/J321081 KJA002-2024
220 kW	2985 r/min COSØ0.90 Th.Cl.155(F) 1400 kg
茵梦达电机(中国)有限公司 Innomotics Standard Motors Ltd.	

轴承系统

1TL0001 系列电动机标准配置深沟球轴承或角接触球轴承，这些轴承是密封的或可再润滑型的。

FS80 ~ 160 范围的 1TL0001 电动机驱动端与非驱动端轴承浮动；FS180 ~ 355 电动机驱动端轴承浮动，非驱动端轴承固定。

标准配置的轴承可以承受一定的悬臂力，当电动机轴端承受的悬臂力较大时，可以考虑选择增强悬臂力的轴承设计（选件号：L22）。

Bearing system

1TL0001 series motors are supplied with the ball bearing as standard. These bearings are either of the sealed or regreaseable type.

For FS80 ~ 160, the floating bearings are assembled; for FS180 ~ 355, floating bearing at DE, and fixed bearing at NDE assembled.

The standard bearing can endure a maximum cantilever force, the increased cantilever bearing design (Option code: L22) should be considered.

轴承选配 Bearing Assignment

机座号 Frame size	极数 Pole	标准配置 Standard design			增强悬臂力设计轴承（选件号：L22） Increased cantilever-bearing (Option code:L22)		
		驱动端轴承 DE bearing	非驱动端轴承 (水平安装) NDE bearing (Horizontal mounting)	非驱动端轴承 (立式安装) NDE bearing (Vertical mounting)	驱动端轴承 DE bearing	非驱动端轴承 (水平安装) NDE bearing (Horizontal mounting)	非驱动端轴承 (立式安装) NDE bearing (Vertical mounting)
80	2, 4, 6	6204 2RZ C3	6204 2RZ C3	6204 2RZ C3	—	—	—
90	2, 4, 6	6205 2RZ C3	6205 2RZ C3	6205 2RZ C3	—	—	—
100	2, 4, 6	6206 2RZ C3	6206 2RZ C3	6206 2RZ C3	6306 2RZ C3	6206 2RZ C3	6206 2RZ C3
112	2, 4, 6	6206 2RZ C3	6206 2RZ C3	6206 2RZ C3	6306 2RZ C3	6206 2RZ C3	6206 2RZ C3
132	2, 4, 6, 8	6208 2RZ C3	6208 2RZ C3	6208 2RZ C3	6308 2RZ C3	6208 2RZ C3	6208 2RZ C3
160	2	6309 2RZ C3	6209 2RZ C3	6209 2RZ C3	—	—	—
	4, 6, 8						
180	2	6310 C3	6210 C3	6210 C3	NU310	6210 C3	6210 C3
	4, 6, 8						
200	2	6312 C3	6212 C3	6212 C3	NU312	6212 C3	6212 C3
	4, 6, 8						
225	2	6313 C3	6213 C3	6213 C3	NU313	6213 C3	6213 C3
	4, 6, 8						
250	2	6314 C3	6215 C3	6215 C3	NU314	6213 C3	O.R.
	4, 6, 8						
280	2, 4, 6, 8	6317 C3	6217 C3	6217 C3	NU317	6217 C3	O.R.
315	2	6319 C3	6317 C3	6317 C3	NU319	6317 C3	O.R.
	4, 6, 8	6319 C3	6319 C3	6319 C3		6319 C3	
355	2	6319 C3	6319 C3	7319	NU319	6319 C3	O.R.
	4, 6, 8	6322 C3	6322 C3	7322	NU322	6322 C3	O.R.

注：DE 驱动端
NDE 非驱动端
— 不能满足
O.R. 须要特殊询价

对160机座，标配轴承配置已做增强悬臂力设计，不需要再加选L22选件

Note: DE Driven end
NDE Non driven end
— Not possible
O.R. Possible on request

For FS160, Increased cantilever-bearing design is utilized as standard. No need for L22

润滑脂寿命和再润滑周期

对于不可再润滑的轴承，其润滑脂寿命与轴承寿命相当。但是，这只能是在电机严格按照本样本中规定的技术数据运行。

对于以规定间隔再润滑的电机，轴承寿命可以延长，从而补偿不利因素，诸如温度、安装条件、转速、轴承规格和机械载荷造成的影响。

Grease life and re-greasing interval

For permanent lubrication, the bearing grease lifetime is matched to the bearing lifetime. This can, however, only be achieved if the motor is operated in accordance with the catalog specifications.

For motors which can be regreased at defined regreasing intervals, the bearing lifetime can be extended and/or unfavorable factors such as temperature, mounting conditions, speed, bearing size and mechanical load can be compensated.

润滑脂寿命和再润滑周期（电动机水平安装） Grease life (Horizontal installation)

机座号 Frame size	极数 Poles	润滑脂寿命 Grease lifetime up to CT 40 °C ¹⁾
持久润滑型轴承的润滑脂 Grease for permanent lubrication bearing		
80 ~ 160	2, 4, 6, 8	20000 或 (or) 40000 ²⁾
可再润滑型轴承的润滑脂 Grease for regreasable bearing		
180 ~ 250	2	4000 小时 (h)
180 ~ 250	4, 6, 8	8000 小时 (h)
280 ~ 315	2	3000 小时 (h)
280 ~ 315	4, 6, 8	5000 小时 (h)
355	2	2000 小时 (h)
355	4, 6, 8	4000 小时 (h)

注:

- ¹⁾ 当环境温度每升高 10 °C，润滑脂寿命以及再润滑时间缩短一半。
- ²⁾ 40000 小时适用于电动机水平安装，且轴不受额外的轴向力影响；

Note:

- ¹⁾ If the coolant temperature is increased by 10 K, the grease lifetime and regreasing interval are halved.
- ²⁾ 40000 h apply to horizontally installed motors with coupling output without additional axial loads.

当电动机在非正常的条件下运行时，轴承的寿命会缩短。如下面几种情况：

- 当电动机的运行速度高于额定速度时，由于电动机的振动增大，使得轴承受到额外的径向力和轴向力，导致其寿命减少；
- 当环境或设备等因素引起电动机振动加大时，同样轴承也会因此受到额外的径向力和轴向力，而导致其寿命减少；
- 当环境温度每升高 10°C，润滑脂寿命以及再润滑时间缩短一半。

- When motor runs beyond the rated speed, the increase of motor vibration will result in the extra radial and axial force on bearing. This will reduce the life of bearing;
- When the motor vibration increase due to the environment or other equipment, the bearing also will endure more radial and axial force. This also will reduce the life of bearing;
- If the coolant temperature is increased by 10 °C, the grease lifetime and regreasing interval is halved.

接线盒技术参数 Connection boxes technical data

机座号 Frame size	接线螺钉螺纹 Contact screw thread	外接电缆直径 (mm) Outer cable diameter (sealing range)	进线孔尺寸 Cable entry size
80 ~ 100	M4	10 ~ 14	M24 x 1.5
112 ~ 132	M5	13 ~ 18	M27 x 2 + M27 x 2
160 ~ 180	M5	18 ~ 25	M36 x 2 + M36 x 2
200 ~ 225	M8	22 ~ 32	M48 x 2 + M48 x 2
250	M10	37 ~ 44	M64 x 2 + M64 x 2
280	M10		
315	M12		
355	M16	38 ~ 47	M72 x 2 + M72 x 2

振动

所有电动机转子都使用半键按照 A 级（标准）振动等级进行动态平衡。

电动机在空载时测得振动速度有效值不超过下表中的 A 级所列值。

振动等级 Vibration Grade	机座号 Frame size (mm)	56 ≤ FS ≤ 132		H > 132	
		位移 Vibration displacement/um	速度 Vibration velocity/(mm/s)	位移 Vibration displacement/um	速度 Vibration velocity/(mm/s)
A	自由悬置 Free suspension	45	2.8	45	2.8
	刚性安装 Rigid mounting	-	-	37	2.3 2.8 ¹⁾
B	自由悬置 Free suspension	18	1.1	29	1.8
	刚性安装 Rigid mounting	-	-	24	1.5 1.8 ¹⁾

注：

¹⁾ 该值为GB/T 10068-2020 中定义的轴中心高H>132mm的两极电机，当两倍电网频率占主导时的振动速度限值。

Vibration

1TL0001 rotors are dynamically balanced to severity grade A using a half key.

Table below contains the effective vibration values for unloaded motors.

Note:

¹⁾ The level are vibration velocity limit when the twice line frequency vibration level is dominant defined by GB/T 10068-2020, for 2p motors that frame size bigger than 132mm.

防潮加热保护

当电动机处于较为恶劣的环境时，比如湿度非常大或者昼夜温差比较大，电动机的绕组很可能出现凝露的现象，这样会带来电动机烧毁的风险。对于这种情况，建议对电动机绕组配置防潮加热带（选件号：Q04）进行保护。

电动机防潮加热带必须在电动机工作过程中处于不工作状态；当电动机停机时，防潮加热带必须启动工作，为绕组加热。防潮加热带的电气参数如下表所示。

防潮加热带电气参数 Electrical data of Anti-condensation heater

机座号 Frame size	功率 Power (W)	电压 Voltage (V)
80 ~ 90	20	220
100 ~ 112	30	220
132 ~ 160	40	220
180 ~ 200	50	220
225 ~ 280	60	220
315	80	220
355	100	220

Anti-condensation heater

Motors whose windings are at risk of condensation due to the climatic conditions, e.g. inactive motors in humid atmospheres or motors that are subjected to widely fluctuating temperatures can be equipped with anti-condensation heaters (Option code: Q04),

2 auxiliary terminals in connection box are needed." Anti-condensation heaters must be switched off during operation. When motor shut down, the heaters must be switched on.

电磁制动器 Electro-Magnetic Brake

1TL0001 系列电动机可附加圆盘型直流电磁制动器，适用于一切要求快速停止、准确定位、往复运转的各种机械。

Disc type DC electro-magnetic brake can be attached to the 1TL0001 series of motors, the motors are suitable for all kinds of machines which require fast stop, accurate positioning and reciprocating operation.

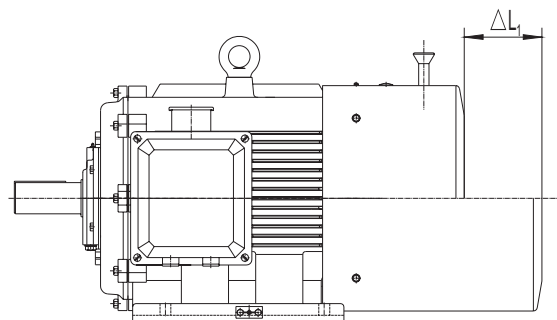

茵梦达电机（中国）有限公司

制动器技术数据 The technical data for the brakes

机座号 Frame size	静制动力矩 (Nm) Static braking torque	空载制动时间 (s) No-load braking time	(开关在直流侧制动器电压) (V) Brake voltage when switch is on the DC side	励磁功率 (W) Excitation power	ΔL_1 (mm)
80	8	0.2	99	50	70
90	15	0.2	99	60	75
100	30	0.2	99	80	75
112	40	0.25	170	110	75
132	80	0.25	170	130	85
160	150	0.35	170	150	105
180	200	0.35	170	150	100
200	300	0.45	170	200	125
225	450	0.45	170	200	140

电气特性

额定输出

1TL0001 电动机的额定功率是指电动机在连续运行的情况下 S1 (IEC 60034-1)，此时周围环境温度在 $-15\text{ }^{\circ}\text{C}$ ~ $40\text{ }^{\circ}\text{C}$ ，海拔高度不超过 1000 m。

电压、频率

IEC 60034-1 将电压和频率的偏差分为 A 类（电压偏差 $\pm 5\%$ ，频率偏差 $\pm 2\%$ ）和 B 类（电压偏差 $\pm 10\%$ ，频率偏差 $+3\% / -5\%$ ）。电动机均能够在 A 类和 B 类提供额定转矩。在 A 类中，温度比正常运行下温度大约提升 10 K。

Electrical design

Rated Output

1TL0001 motors rated output powers means that the motor runs under continuous duty S1 (IEC 60034 - 1) operation when operated at ambient temperature from $-15\text{ }^{\circ}\text{C}$ to $40\text{ }^{\circ}\text{C}$ and at altitudes of up to 1000 m over sea.

Voltage and Frequency

IEC 60034-1 differentiates between Category A (combination of voltage deviation $\pm 5\%$ and frequency deviation $\pm 2\%$) and Category B (combination of voltage deviation $\pm 10\%$ and frequency deviation $+3\% / -5\%$) for voltage and frequency fluctuations. The motors can supply their rated torque in both Category A and B. In Category A, the temperature rise is approximately 10 K higher than during normal operation.

标准 Standard 60034 - 1	类别 Category A	类别 Category B
电压偏差 Voltage deviation	$\pm 5\%$	$\pm 10\%$
频率偏差 Frequency deviation	$\pm 2\%$	$+3\% / -5\%$
根据标准，不推荐电动机在 B 类情况下长时间运行 According to the standard, longer operation is not recommended for Category B.		

电气数据公差

■ 效率 η

$$-0.15 \times (1 - \eta)$$

效率 η 为小于 1 的值

■ 功率因数: $(1 - \cos \phi) / 6$

最小绝对值: 0.02

最大绝对值: 0.07

■ 转差率: $\pm 20\%$ (电动机的偏差 $< 1\text{ kW}$ $\pm 30\%$ 时是允许的)

■ 堵转电流: $+20\%$

■ 堵转转矩: $-15\% \sim +25\%$

■ 最大转矩: -10%

■ 转动惯量: $\pm 10\%$

Tolerance for electrical data

■ Efficiency η

$$-0.15 \times (1 - \eta)$$

With η being a decimal number

■ Power factor - $(1 - \cos \phi) / 6$

Minimum absolute value: 0.02

Maximum absolute value: 0.07

■ Slip $\pm 20\%$ (for motors $< 1\text{ kW}$ $\pm 30\%$ is admissible)

■ Locked-rotor current $+20\%$

■ Locked-rotor torque -15% to $+25\%$

■ Breakdown torque -10%

■ Moment of inertia $\pm 10\%$

变频应用 Converter fed application

1TL0001 电动机适于变转速、恒转速的各种应用，如风机、泵、压缩机、纺织机械等。

1TL0001 电动机的标准绝缘系统设计要求，能够保证其在变频器供电电压不超过 460 V 时正常运行。

1TL0001 电动机带有特定的负载时能够使用变频器驱动，其特定的负载扭矩如以下图表所示：

1TL0001 motors are suitable for pumps, fans, compressors, textile machine and mechanical machine applications where variable or constant speed is required.

The standard insulation of the 1TL0001 motors is designed such that operation is possible on the converter at mains voltage up to 460 V.

1TL0001 motors are capable for converter-fed operation with certain characteristics load, of which the load torque characteristics is referred in the following diagram:

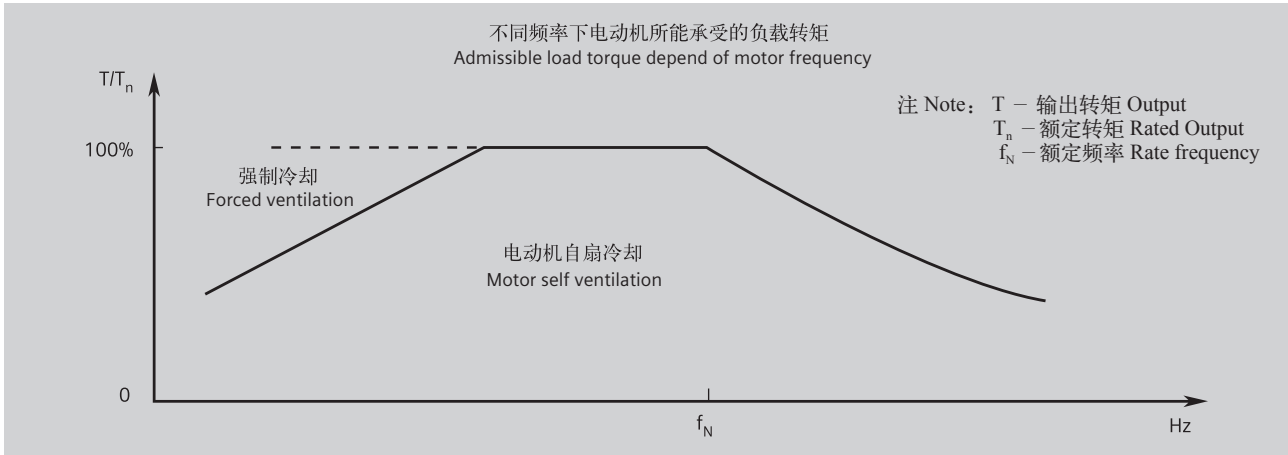

当 1TL0001 电动机变频应用（变频器供电），且输出额定功率时，电动机的使用温度等级为 155 (F)。为了避免杂散电流对电动机轴承的损坏，推荐 FS250 ~ 355 电动机使用绝缘轴承。请向茵梦达咨询关于绝缘轴承的详细信息。

当负载扭矩在允许的转矩范围内时，电动机能够自扇冷却；当负载扭矩超过所允许的转矩时，电动机需要强迫冷却。

在电动机运行速度超过额定转速时，噪声和振动值将增加，并且轴承的寿命将缩短。需要注意再润滑周期和润滑脂的寿命。

At rated output with converter fed operation, the motors will be used in temperature class 155 (F). To prevent damage as a result of bearing currents, insulated bearings are recommended to be assembled for frame size 250 and above. Please inquire INNOMOTICS about the detailed information of insulated bearing.

By usage with admissible torque and below, the motor can be operated with self cooling; by usage over the admissible torque line, the motor with forced ventilation is needed.

At operating speeds above rated speed the noise and vibration levels increase and the bearing life time reduce. Attention should be paid to the re-greasing intervals and the grease service life.

1TL0001 电动机所允许的最大安全转速如下表

The allowed maximum safe operating speed of 1TL0001 motors shows the diagram

机座号 Frame size	2 极 2 pole		4 极 4 pole		6 极 6 pole		8 极 8 pole	
	最高转速 Max.rpm	最大频率 fmax	最高转速 Max.rpm	最大频率 fmax	最高转速 Max.rpm	最大频率 fmax	最高转速 Max.rpm	最大频率 fmax
80	5200	87	3600	120	2400	120	1800	120
90	5200	87	3600	120	2400	120	1800	120
100	5200	87	3600	120	2400	120	1800	120
112	5200	87	3600	120	2400	120	1800	120
132	4500	75	2700	90	2400	120	1800	120
160	4500	75	2700	90	2400	120	1800	120
180	4500	75	2700	90	2400	120	1800	120
200	4500	75	2300	77	1800	90	1400	93
225	3600	60	2300	77	1800	90	1400	93
250	3600	60	2300	77	1800	90	1400	93
280	3600	60	2300	77	1800	90	1400	93
315	3600	60	2300	77	1800	90	1400	93
355	3600	60	2300	77	1800	90	1400	93

独立驱动风扇技术参数 Technical data for separately fan

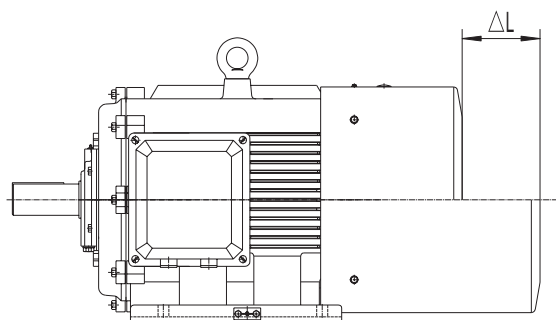

独立驱动风扇技术参数 Technical data for separately fan

对应电动机座号 Motor frame size	额定电压 (V) rated voltage	额定频率 (Hz) Rated frequency	功率 (W) Rated output	电流 (A) Current	转速 (r/min) Speed	ΔL
80	220D/380Y	50	30	0.14/0.08	2800	60
90		50	30	0.14/0.08	2800	75
100		50	52	0.21/0.12	2800	65
112		50	52	0.21/0.12	2800	75
132		50	45	0.35/0.2	1400	75
160		50	45	0.35/0.2	1400	45
180		50	120	1.04/0.6	1400	55
200		50	120	1.04/0.6	1400	60
225		50	120	1.04/0.6	1400	60
250		50	230	1.73/1.0	1400	60
280		50	230	1.73/1.0	1400	105
315(2P)		50	1100	4.33/2.5	1350	145
315(4~8P)		50	370	1.91/1.1	1250	95
355		50	550	2.18/1.26	1350	100

注：风扇可以在 210 ~ 240VD/360 ~ 420VY 50Hz 电源供电下运行，也可以在 220 ~ 260VD/380 ~ 480VY 60Hz 电源供电下运行。其他电源供电，须特殊询价。

Note: The fan can be running with supply 210 ~ 240VD/360 ~ 420VY 50Hz, and also 220 ~ 260VD/380 ~ 480VY 60Hz. Other voltage supply, possible on request.

风机电机参数 Technical data for fan motor

对于某些客户现场有外部冷却设备的应用，可以提供无风扇和风扇罩的风机电机，风机电机的选件号为 F90。当电机无风扇和风扇罩时，电动机的长度将减少 ΔL。

For some special application with external cooling facility, we can provide motor without fan and fan cover, the option code is F90. When motor without fan and fan cover, the length will decrease ΔL.

对应电动机座号 motor frame size	F90 电机减少长度 ΔL Length decrease of motor ΔL
80	50
90	55
100	65
112	65
132	70
160	90
180	105
200	110
225	115
250	125
280	135
315	175
355	165

型号与订货号 Motor Type and Order No.

电动机订货号

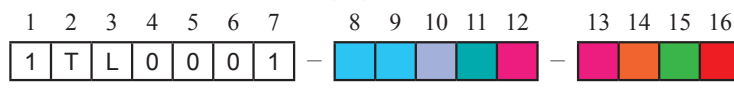

低压铸铁系列电动机 Low-voltage Cast Iron motor

机座号编号 Code of frame size

0D = 080 / 0E = 090

1A = 100 / 1B = 112 / 1C = 132 / 1D = 160 / 1E = 180

2A = 200 / 2B = 225 / 2C = 250 / 2D = 280

3A = 315 / 3B = 355

极数编号 Code of poles

A = 2 / B = 4 / C = 6 / D = 8

机座长度编号 Code of frame length

0 or 1 = S (short) / 2 or 3 or 4 = M (medium) / 4 or 5 or 6 or 7 = L (long)

电压, 连接方式和频率编号 Code of voltage, connections and frequency

04¹⁰⁾ = 400VD 50Hz

22⁹⁾¹⁰⁾ = 230VD / 400VY 50Hz 35¹⁰⁾ = 415VD 50Hz

21⁹⁾¹⁰⁾ = 220VD / 380VY 50Hz 23⁹⁾¹⁰⁾ = 240VD / 415VY 50Hz 90¹⁾ = 特殊电压与频率 special voltage & frequency

33¹⁰⁾ = 380VD / 660VY 50Hz 34¹⁰⁾ = 400VD / 690VY 50Hz

结构和安装方式编号 Code of Construction and mounting type

T²⁾ = IM B6

A²⁾ = IM B3

U²⁾ = IM B7

W^{2) 5)} = IM V15

M^{2) 3) 4) 5)} = IM V18

J²⁾ = IM B35

V²⁾ = IM B8

Y²⁾ = IM V35

L^{2) 5)} = IM V19

F^{2) 3)} = IM B5

C^{2) 5)} = IM V5

G^{2) 3) 5)} = IM V1

N^{2) 4)} = IM B34

K^{2) 3) 4)} = IM B14

D²⁾ = IM V6

H^{2) 3)} = IM V3

绕组保护编号 Code of winding protection

A = 无绕组保护 without winding protection

B⁶⁾ = 绕组带 3 个 PTC 热敏电阻用于跳闸 3 PTC thermistors for tripping

C⁶⁾ = 绕组带 6 个 PTC 热敏电阻用于报警和跳闸 6 PTC thermistors for alarm and tripping

H⁶⁾⁷⁾ = 绕组带 3 个 Pt100 测温元件 3 resistance thermometers Pt100

J⁶⁾⁷⁾ = 绕组带 6 个 Pt100 测温元件 6 resistance thermometers Pt100

Z⁸⁾ = 其他绕组保护 Other temperature for winding protection

接线盒位置编号 (从驱动端看) Code location of connection box (view from drive end)

4 = 顶端出线 top / 5 = 右端出线 on RHS / 6 = 左端出线 on LHS

附注:

- 1) 用电压编号 90 及相应选件号来定制其它电压 (参见选件描述) ;
- 2) 铭牌上标有结构型式。若需要冷凝水排放孔 (订货号: H03) , 则必须指明电机的安装结构型式, 以便在制造过程中确定冷凝水排放孔的具体位置;
- 3) 对于 IM B5、IM V1、IM V3、IM B14、IM V18 和 IM V19 安装结构型式电动机, 须指定电动机订货号第 16 位数字为“4”;
- 4) 只适用于 FS80 ~ 112;
- 5) 电动机标配无防雨罩, 但如需要加带防雨罩用于防护时, 须订购选件号 H00;
- 6) 选择此选件, 接线盒将更改为铸铁壳;
- 7) 仅适用于机座号 100-355;
- 8) 请向茵梦达另行咨询;
- 9) 不适用于 FS315 ~ 355 电机;
- 10) 只适用于 F70 和 F90 选件。

Foot note:

- 1) Order other voltages with voltage code 90 and the corresponding Option code (see under "Option") .
- 2) The type of construction is stamped on the rating plate. When ordering with condensation drainage holes (order code H03), it is absolutely necessary to specify the type of construction for the exact position of the condensation drainage holes during manufacture.
- 3) For motor with IM B5, IM V1, IM V3, IM B14, IM V18 and IM V19 construction and mounting type, the 16th digit of motor order No. must be "4";
- 4) Only for FS80 ~ 112.
- 5) Without canopy, for protective cover with canopy needed Option code H00.
- 6) Choose this option, the connection box will be changed to cast iron.
- 7) Only applicable for frame size 100-355.
- 8) Please specially consult with INNOMOTICS.
- 9) Not applicable for FS315 ~ 355 motors.
- 10) Only suitable for F70 and F90.

选型技术数据表 Technical data table

铸铁壳系列电机 Cast Iron Motors

机座号 Frame Size	额定 功率 Rate Output 50 Hz	型号 Order No.	额定 转速 Rated Speed	效率 (100% 负载) Efficiency at (50 HZ) 4/4 load	效率 (75% 负载) Efficiency at (50 HZ) 3/4 load	功率 因数 Power factor	额定 电流 Rated current	额定 转矩 Rated torque	起动 电流 / 额定 电流 Starting current /Rated current	起动 转矩 / 额定 转矩 Starting torque/ Rated torque	最大 转矩 / 额定 转矩 Max torque / Rated torque	转动 惯量 Moment of Inertia	重量 IMB3 Weight
	kW		rpm	%	%		A	Nm	直接起动对额定转矩 (电流) 的倍数 Direct start to rated torque (current) multiples			kgm ²	kg
3000rpm 2 极 2-pole													
220VD / 380VY 50HZ													
80M	0.75	1TL0001-0DA22-1 □□□□	2795	77.4	78.5	0.84	1.75	2.6	5.6	2.4	2.4	0.00080	13.5
80M	1.1	1TL0001-0DA32-1 □□□□	2835	79.6	80.6	0.84	2.50	3.7	6	2.8	3.2	0.0012	15.0
90S	1.5	1TL0001-0EA02-1 □□□□	2890	81.3	81.7	0.84	3.35	5.0	6.5	2.4	3.1	0.0021	19.0
90L	2.2	1TL0001-0EA42-1 □□□□	2890	83.2	83.7	0.85	4.75	7.3	7.2	2.6	3.5	0.0026	23
100L	3	1TL0001-1AA42-1 □□□□	2885	84.6	85.1	0.84	6.4	9.9	7.5	4	4.5	0.0036	30
3000rpm 2 极 2-pole													
380VD / 660VY 50HZ													
112M	4	1TL0001-1BA23-3 □□□□	2930	85.8	86.6	0.86	8.2	13.0	7.5	2.2	2.9	0.0064	37
132S	5.5	1TL0001-1CA03-3 □□□□	2930	87	87.6	0.87	11.0	17.9	7.5	2.2	2.9	0.014	54
132S	7.5	1TL0001-1CA13-3 □□□□	2930	88.1	88.8	0.89	14.5	24.4	7.5	2.3	2.9	0.017	59
160M	11	1TL0001-1DA23-3 □□□□	2935	89.4	90.1	0.86	21.5	35.8	7.5	2.2	2.9	0.031	93
160M	15	1TL0001-1DA33-3 □□□□	2935	90.3	91	0.86	29.5	48.8	7.5	2.4	3.2	0.038	103
160L	18.5	1TL0001-1DA43-3 □□□□	2935	90.9	91.7	0.89	34.5	60.2	7.5	2.4	3.2	0.046	118
180M	22	1TL0001-1EA23-3 □□□□	2935	91.3	91.8	0.87	42.0	71.6	7.6	2.5	3.2	0.072	151
200L	30	1TL0001-2AA43-3 □□□□	2955	92	92.3	0.86	58	97.0	7.5	2.5	3.2	0.13	215
200L	37	1TL0001-2AA53-3 □□□□	2955	92.5	92.8	0.88	69	119.6	7.5	2.5	3.2	0.15	240
225M	45	1TL0001-2BA23-3 □□□□	2965	92.9	93.1	0.88	84	144.9	7.9	2.5	3.1	0.24	277
250M	55	1TL0001-2CA23-3 □□□□	2970	93.2	93.2	0.88	102	176.9	7.5	2.5	3	0.42	309
280S	75	1TL0001-2DA03-3 □□□□	2975	93.8	93.8	0.87	140	240.8	7.5	2.8	3	0.75	440
280M	90	1TL0001-2DA23-3 □□□□	2978	94.1	94.1	0.87	167	288.6	7.5	3	3.1	0.88	520
315S	110	1TL0001-3AA03-3 □□□□	2982	94.3	94.3	0.90	197	352.3	7.5	2.2	2.6	1.4	750
315M	132	1TL0001-3AA23-3 □□□□	2982	94.6	94.6	0.91	235	422.7	7.5	2.3	2.9	1.7	905
315L	160	1TL0001-3AA53-3 □□□□	2982	94.8	95.1	0.92	280	512.4	7.5	2.5	2.8	1.9	945
315L	185	1TL0001-3AA63-3 □□□□	2982	95	95.3	0.92	320	592.5	7.5	2.5	2.8	2.3	1060
315L	200	1TL0001-3AA73-3 □□□□	2982	95	95.3	0.92	350	640.5	7.5	2.5	2.8	2.3	1070
355M	220	1TL0001-3BA23-3 □□□□	2985	95.0	94.7	0.90	390	704	7.0	2.0	2.6	2.5	1400
355M	250	1TL0001-3BA33-3 □□□□	2985	95.0	94.7	0.90	445	800	7.4	2.3	2.8	2.7	1460
355L	280	1TL0001-3BA53-3 □□□□	2985	95.0	95.1	0.91	490	896	7.0	2.2	2.6	3.0	1540
355L	315	1TL0001-3BA63-3 □□□□	2985	95.0	95.0	0.91	550	1008	7.4	2.5	2.8	3.3	1670

注: ¹⁾ 关于其他电压与频率、绕组保护及接线盒位置的编码, 请见第 14 页“订货号”部分;

²⁾ 噪声值仅适用于电动机在 50 Hz 电源直接供电且空载运行时的情况, 容差为 +3 dB。

只适用于冷却方式为 IC416 (选件代码 F70) 或 IC418 (选件代码 F90) 电机。

Note: ¹⁾ About the code of other voltage and frequency, winding protection and connection box position, please refer to Orde No. in page 14.

²⁾ Noise value is only applicable to the direct power supply of the motor in 50Hz power supply and the condition of no-load operation, the tolerance is +3dB.

Only suitable for cooling method IC416(Option code F70), IC418(Option code F70) motor.

选型技术数据表 Technical data table

铸铁壳系列电机 Cast Iron Motors

机座号 Frame Size	额定 功率 Rate Output 50 Hz	型号 Order No.	额定 转速 Rated Speed	效率 (100% 负载) Efficiency at (50 HZ) 4/4 load	效率 (75% 负载) Efficiency at (50 HZ) 3/4 load	功率 因数 Power factor	额定 电流 Rated current	额定 转矩 Rated torque	起动 电流 / 额定 电流 Starting current /Rated current	起动 转矩 / 额定 转矩 Starting torque/ Rated torque	最大 转矩 / 额定 转矩 Max torque / Rated torque	转动 惯量 Moment of Inertia	重量 IMB3 Weight
	kW		rpm	%	%		A	Nm	直接起动对额定转矩 (电流) 的倍数 Direct start to rated torque (current) multiples			kgm ²	kg
1500rpm 4 极 4-pole													
220VD / 380VY 50HZ													
80M	0.55	1TL0001-0DB22-1 □□□□	1425	74.0	74.7	0.8	1.40	3.7	6	2	2.7	0.0021	14.0
80M	0.75	1TL0001-0DB32-1 □□□□	1440	79.6	79.6	0.75	1.90	5.0	6.5	2.8	3.5	0.0027	15.5
90S	1.1	1TL0001-0EB02-1 □□□□	1440	81.4	81.4	0.75	2.75	7.3	7	2.8	3.5	0.0041	20
90L	1.5	1TL0001-0EB42-1 □□□□	1435	82.8	82.8	0.76	3.60	9.9	7	3	3.8	0.0047	23
100L	2.2	1TL0001-1AB42-1 □□□□	1435	84.3	85	0.79	5.0	14.6	7	3	3.2	0.0081	30
100L	3	1TL0001-1AB52-1 □□□□	1435	85.5	86.3	0.79	6.7	20.0	7	3	3.2	0.010	33
1500rpm 4 极 4-pole													
380VD / 660VY 50HZ													
112M	4	1TL0001-1BB23-3 □□□□	1445	86.6	87.1	0.79	8.9	26.4	7.1	2.7	3.1	0.011	42
132S	5.5	1TL0001-1CB03-3 □□□□	1460	87.7	88.2	0.79	12.1	36.0	7.5	2.5	3.1	0.021	58
132M	7.5	1TL0001-1CB23-3 □□□□	1460	88.7	89.4	0.82	15.7	49.1	7.7	2.7	3.2	0.029	72
160M	11	1TL0001-1DB23-3 □□□□	1465	89.8	90.4	0.84	22.0	71.7	7.5	2.5	3.1	0.051	99
160L	15	1TL0001-1DB43-3 □□□□	1465	90.6	91.3	0.85	29.5	97.8	7.8	2.7	3.2	0.066	120
180M	18.5	1TL0001-1EB23-3 □□□□	1465	91.2	91.8	0.85	36.5	120.6	7.3	2.5	3.2	0.13	163
180L	22	1TL0001-1EB43-3 □□□□	1465	91.6	92.3	0.85	43.0	143.4	7.3	2.4	3.2	0.14	182
200L	30	1TL0001-2AB43-3 □□□□	1470	92.3	92.9	0.85	58	194.9	7.3	2.7	3.2	0.22	227
225S	37	1TL0001-2BB03-3 □□□□	1475	92.7	93.2	0.86	71	239.6	7.3	2.7	3.2	0.45	262
225M	45	1TL0001-2BB23-3 □□□□	1475	93.1	93.5	0.87	84	291.4	7.3	2.7	3.2	0.51	284
250M	55	1TL0001-2CB23-3 □□□□	1480	93.5	93.9	0.86	104	354.9	7.5	3.1	3.5	0.80	330
280S	75	1TL0001-2DB03-3 □□□□	1485	94	94.3	0.87	139	482.3	7.5	2.7	3.1	1.4	480
280M	90	1TL0001-2DB23-3 □□□□	1485	94.2	94.3	0.87	167	578.8	7.5	2.7	3.1	1.5	555
315S	110	1TL0001-3AB03-3 □□□□	1488	94.5	94.5	0.86	205	706.0	7.3	2.8	2.9	2.2	750
315M	132	1TL0001-3AB23-3 □□□□	1486	94.7	94.7	0.88	240	848.3	7.3	2.5	2.7	2.5	880
315L	160	1TL0001-3AB53-3 □□□□	1488	94.9	94.9	0.88	290	1026.9	7.4	3	2.9	3.0	965
315L	185	1TL0001-3AB63-3 □□□□	1488	95.1	95.1	0.88	335	1187.3	7.4	3	3	3.6	1060
315L	200	1TL0001-3AB73-3 □□□□	1488	95.1	95.1	0.88	365	1283.6	7.4	3	3	3.7	1080
355M	220	1TL0001-3BB23-3 □□□□	1490	95.1	95.2	0.89	395	1411	6.9	1.7	2.5	4.9	1580
355M	250	1TL0001-3BB33-3 □□□□	1490	95.1	95.2	0.89	450	1604	6.9	1.8	2.5	5.0	1630
355L	280	1TL0001-3BB53-3 □□□□	1490	95.1	95.3	0.89	500	1795	7.0	1.9	2.7	5.3	1680
355L	315	1TL0001-3BB63-3 □□□□	1490	95.1	95.2	0.89	570	2019	7.0	1.9	2.7	5.7	1760

注: ¹⁾ 关于其他电压与频率、绕组保护及接线盒位置的编码, 请见第 14 页“订货号”部分;

²⁾ 噪声值仅适用于电动机在 50 Hz 电源直接供电且空载运行时的情况, 容差为 +3 dB。

只适用于冷却方式为 IC416 (选件代码 F70) 或 IC418 (选件代码 F90) 电机。

Note: ¹⁾ About the code of other voltage and frequency, winding protection and connection box position, please refer to Orde No. in page 14.

²⁾ Noise value is only applicable to the direct power supply of the motor in 50Hz power supply and the condition of no-load operation, the tolerance is +3dB.

Only suitable for cooling method IC416(Option code F70), IC418(Option code F90) motor.

选型技术数据表 Technical data table

铸铁壳系列电机 Cast Iron Motors

机座号 Frame Size	额定 功率 Output 50 Hz	型号 Order No.	额定 转速 Rated Speed	效率 (100% 负载) Efficiency at (50 HZ) 4/4 load	效率 (75% 负载) Efficiency at (50 HZ) 3/4 load	功率 因数 Power factor	额定 电流 Rated current	额定 转矩 Rated torque	起动 电流 / 额定 电流 Starting current /Rated current	起动 转矩 / 额定 转矩 Starting torque/ Rated torque	最大 转矩 / 额定 转矩 Max torque / Rated torque	转动 惯量 Moment of Inertia	重量 IMB3 Weight
	kW		rpm	%	%		A	Nm	直接起动对额定转矩 (电流) 的倍数 Direct start to rated torque (current) multiples			kgm ²	kg
1000rpm 6极 6-pole													
220VD / 380VY 50HZ													
80M	0.55	1TL0001-0DC32-1 □□□□	895	71	72	0.76	1.55	5.9	4.5	2.3	2.3	0.0028	16.0
90S	0.75	1TL0001-0EC02-1 □□□□	935	75.9	76.5	0.71	2.10	7.7	5	2.1	2.6	0.0038	20
90L	1.1	1TL0001-0EC42-1 □□□□	945	78.1	78.1	0.71	3.00	11.1	5.5	2.4	2.8	0.0046	24
100L	1.5	1TL0001-1AC42-1 □□□□	945	79.8	80.1	0.74	3.85	15.2	5.5	2.4	2.9	0.0086	31
112M	2.2	1TL0001-1BC22-1 □□□□	950	81.8	82.5	0.73	5.6	22.1	5.5	2.6	3.3	0.012	41
132S	3	1TL0001-1CC02-1 □□□□	960	83.3	84.3	0.73	7.5	29.8	6	2	2.2	0.019	54
1000rpm 6极 6-pole													
380VD / 660VY 50HZ													
132M	4	1TL0001-1CC23-3 □□□□	960	84.6	85.4	0.73	9.8	39.8	6.2	2.2	2.5	0.024	65
132M	5.5	1TL0001-1CC33-3 □□□□	960	86	86.6	0.75	13.0	54.7	6.4	2.4	2.6	0.031	73
160M	7.5	1TL0001-1DC23-3 □□□□	975	87.2	87.9	0.77	17.0	73.5	6.4	2.1	2.6	0.1069	103
160L	11	1TL0001-1DC43-3 □□□□	975	88.7	89.4	0.78	24.0	108	6.4	2.1	2.6	0.14	120
180L	15	1TL0001-1EC43-3 □□□□	975	89.7	90.4	0.78	32.5	146.9	6.5	2.3	3	0.18	163
200L	18.5	1TL0001-2AC43-3 □□□□	975	90.4	91	0.81	38.5	181.2	6.5	2.3	2.8	0.27	210
200L	22	1TL0001-2AC53-3 □□□□	975	90.9	91.4	0.82	45.0	215.5	6.5	2.3	2.8	0.32	228
225M	30	1TL0001-2BC23-3 □□□□	980	91.7	92.3	0.83	60	292.3	6.5	2.2	2.8	0.62	282
250M	37	1TL0001-2CC23-3 □□□□	982	92.2	92.8	0.83	73	359.8	7	2.5	2.8	0.91	332
280S	45	1TL0001-2DC03-3 □□□□	985	92.7	93.3	0.85	87	436.3	7.5	2.5	2.8	1.2	410
280M	55	1TL0001-2DC23-3 □□□□	986	93.1	93.7	0.85	106	532.7	7.5	2.5	2.8	1.5	485
315S	75	1TL0001-3AC03-3 □□□□	986	93.7	94.3	0.85	143	726.4	7.3	2.3	2.8	2.3	690
315M	90	1TL0001-3AC23-3 □□□□	986	94	94.5	0.85	171	871.7	7.3	2.3	2.8	2.8	830
315L	110	1TL0001-3AC53-3 □□□□	988	94.3	94.7	0.86	205	1063.3	7.5	2.4	2.8	3.9	965
315L	132	1TL0001-3AC63-3 □□□□	988	94.6	95	0.86	245	1275.9	7.5	2.5	3	4.3	1010
355M	160	1TL0001-3BC23-3 □□□□	991	94.8	95.4	0.87	295	1542	7.0	2.4	2.2	8.9	1610
355M	185	1TL0001-3BC33-3 □□□□	991	95.0	95.5	0.87	340	1783	7.1	2.6	2.6	9.4	1750
355M	200	1TL0001-3BC43-3 □□□□	991	95.0	95.5	0.87	370	1930	7.1	2.6	2.6	10.5	1750
355L	220	1TL0001-3BC53-3 □□□□	991	95.0	95.5	0.87	405	2121	7.6	2.6	2.6	11.5	1850
355L	250	1TL0001-3BC63-3 □□□□	992	95.0	95.4	0.87	460	2408	7.8	2.8	2.7	12.9	1930

注:

¹⁾ 关于其他电压与频率、绕组保护及接线盒位置的编码, 请见第 14 页“订货号”部分;

²⁾ 噪声值仅适用于电动机在 50 Hz 电源直接供电且空载运行时的情况, 容差为 +3 dB。

只适用于冷却方式为 IC416 (选件代码 F70) 或 IC418 (选件代码 F90) 电机。

Note:

¹⁾ About the code of other voltage and frequency, winding protection and connection box position, please refer to Orde No. in page 14.

²⁾ Noise value is only applicable to the direct power supply of the motor in 50Hz power supply and the condition of no-load operation, the tolerance is +3dB.

Only suitable for cooling method IC416(Option code F70), IC418(Option code F70) motor.

选型技术数据表 Technical data table

铸铁壳系列电机 Cast Iron Motors

机座号 Frame Size	额定 功率 Rate Output 50 Hz	型号 Order No.	额定 转速 Rated Speed	效率 (100% 负载) Efficiency at (50 Hz) 4/4 load	效率 (75% 负载) Efficiency at (50 Hz) 3/4 load	功率 因数 Power factor	额定 电流 Rated current	额定 转矩 Rated torque	起动 电流 / 额定 电流 Starting current /Rated current	起动 转矩 / 额定 转矩 Starting torque/ Rated torque	最大 转矩 / 额定 转矩 Max torque / Rated torque	转动 惯量 Moment of Inertia	重量 IMB3 Weight
	kW		rpm	%	%		A	Nm	直接起动对额定转矩 (电流) 的倍数 Direct start to rated torque (current) multiples			kgm ²	kg
750rpm 8极 8-pole													
220VD/380VY 50HZ													
132S	2.2	1TL0001-1CD02-1 □□□□	725	77.6	78.3	0.70	6.2	29.2	4.6	1.9	3	0.022	79
132M	3	1TL0001-1CD22-1 □□□□	720	80.0	80.3	0.75	7.6	40	4.8	2	3	0.037	79
750rpm 8极 8-pole													
380VD/660VY 50HZ													
160M	4	1TL0001-1DD23-3 □□□□	730	81.9	82.1	0.66	11.2	52	4.9	1.8	2.8	0.051	97
160M	5.5	1TL0001-1DD33-3 □□□□	720	83.8	84.1	0.68	14.7	73	4.6	1.5	2.0	0.051	105
160L	7.5	1TL0001-1DD43-3 □□□□	730	85.3	85.5	0.67	19.9	99	5	1.7	2.3	0.067	121
180L	11	1TL0001-1ED43-3 □□□□	715	86.9	87.2	0.75	25.5	147	5	2.1	2.6	0.20	163
200L	15	1TL0001-2AD53-3 □□□□	715	88.0	88.1	0.78	33.0	200	6	2.3	2.9	0.35	233
225S	18.5	1TL0001-2BD03-3 □□□□	729	88.6	88.9	0.77	41.0	240	6.6	2.4	3	0.48	246
225M	22	1TL0001-2BD23-3 □□□□	728	89.1	89.4	0.79	47.5	290	7	2.7	2.8	0.56	286
250M	30	1TL0001-2CD23-3 □□□□	732	89.8	90.0	0.81	63	390	6.3	2.2	2.7	0.94	330
280S	37	1TL0001-2DD03-3 □□□□	736	90.3	90.4	0.78	80	480	6.5	2.5	2.7	1.2	395
280M	45	1TL0001-2DD23-3 □□□□	738	90.7	90.8	0.79	94	582	6.3	2.2	2.7	1.5	479
315S	55	1TL0001-3AD03-3 □□□□	740	91.0	91.1	0.81	113	710	6.2	2	2.9	2.1	665
315M	75	1TL0001-3AD23-3 □□□□	738	91.6	92.1	0.81	154	970	6.7	2.2	2.5	2.6	845
315L	90	1TL0001-3AD53-3 □□□□	738	91.9	92.5	0.83	179	1165	5.9	1.8	2.3	3.3	890
315L	110	1TL0001-3AD63-3 □□□□	741	92.3	92.6	0.83	220	1418	7.1	2.3	3	4.2	1040
355M	132	1TL0001-3BD23-3 □□□□	743	92.6	93.2	0.81	265	1699	7.1	2.2	2.4	8.2	1530
355M	160	1TL0001-3BD33-3 □□□□	742	93.0	93.5	0.82	320	2059	7.1	2.2	2.4	9.6	1650
355L	185	1TL0001-3BD53-3 □□□□	742	93.3	93.9	0.84	360	2382	7.1	2.0	2.1	11.4	1820
355L	200	1TL0001-3BD63-3 □□□□	742	93.5	94.0	0.84	385	2576	7.4	2.0	2.1	12.7	1930

注:

¹⁾ 关于其他电压与频率、绕组保护及接线盒位置的编码, 请见第 14 页“订货号”部分;

²⁾ 噪声值仅适用于电动机在 50 Hz 电源直接供电且空载运行时的情况, 容差为 +3 dB。

只适用于冷却方式为 IC416 (选件代码 F70) 或 IC418 (选件代码 F90) 电机。

Note:

¹⁾ About the code of other voltage and frequency, winding protection and connection box position, please refer to Orde No. in page 14.

²⁾ Noise value is only applicable to the direct power supply of the motor in 50Hz power supply and the condition of no-load operation, the tolerance is +3dB.

Only suitable for cooling method IC416(Option code F70), IC418(Option code F70) motor.

选件 Options

电动机订货号 Motor order code	选件号 ¹⁾ Option Code	描述 Description	应用范围 Application Scope
电压与频率 Voltages and frequency			
1TL0001- □□□□ 9-0 □□□ -Z	M2A ²⁾¹⁷⁾	220VD/380VY 60Hz, 50Hz 功率输出 power output	FS80 ~ 355
	M2B ³⁾¹⁷⁾	380VD/660VY 60Hz, 50Hz 功率输出 power output	FS80 ~ 355
	M2C ²⁾¹⁷⁾	440VY 60Hz, 50Hz 功率输出 power output	FS80 ~ 280
	M2D ³⁾¹⁷⁾	440VD 60Hz, 50Hz 功率输出 power output	FS80 ~ 355
	M2E ²⁾¹⁷⁾	460VY 60Hz, 50Hz 功率输出 power output	FS80 ~ 280
	M2F ³⁾¹⁷⁾	460VD 60Hz, 50Hz 功率输出 power output	FS80 ~ 355
线圈和绝缘 Windings and insulation			
—	N01 ¹⁸⁾	温度等级 155 (F), 使用 155 (F), 带有服务系数 (SF1.15) Temperature class 155 (F), used according to 155 (F), with service factor (SF1.15)	FS80 ~ 355
—	N10	180 (H) 度温度等级绝缘 Temperature class 180 (H)	FS80 ~ 355
—	Q04 ⁴⁾	绕组带 220 V 防潮加热带 Anti-condensation heater for 220 VAC (spaces heater)	FS80 ~ 355
电动机接线盒 Motor connection box			
—	R10 ⁵⁾	接线盒直接旋转 90°, 进线口朝向驱动端 Rotation of the connection box through 90°, entry from DE	FS80 ~ 355
—	R11 ⁶⁾	接线盒直接旋转 90°, 进线口朝向非驱动端 Rotation of the connection box through 90°, entry from NDE	FS80 ~ 355
—	R12	接线盒直接旋转 180° Rotation of the connection box through 180°	FS80 ~ 355
—	H04	外部接地 external earthing	FS80 ~ 280
—	X07	铸铁接线盒 cast iron connection box	FS80 ~ 355
—	X47	电机接线盒标配 2 个自锁葛兰 Connection boxes of the motors include 2 self-locking cable gland	FS112 ~ 355
轴承 Bearings			
—	Q72	轴承带两个 PT100 测温元件 Installation of 2PT100 screw-in resistance thermometers for bearing	FS180 ~ 355
—	L80	SKF 轴承 SKF Bearing	FS80 ~ 355
—	L81	其他进口品牌轴承 Other imported brand bearings	FS80 ~ 355
—	L20	驱动端轴承固定 Located bearing at DE	FS80 ~ 160
—	L22 ⁷⁾	增强悬臂力 Increased cantilever forces	FS100 ~ 355
—	L51 ²⁰⁾	非驱动端轴承绝缘 Bearing insulation NDE	FS250 ~ 355

¹⁾ 订货时, 电动机订货号需带“-Z”, 另外附上选件号;

²⁾ 一般适用于 3kW 及以下功率的电机;

³⁾ 一般适用于 3kW 以上功率的电机;

⁴⁾ 选择此选件, 接线盒将更改为铸铁壳;

⁵⁾ 不适用 FS80-100 法兰安装电机;

¹⁾ Order No. supplement Z with option code when ordering.

²⁾ Only applicable to the motor whose power is 3kW and below.

³⁾ Only applicable to the motor whose power is 3kW and above.

⁴⁾ When choose these options, the connection boxes will be changed to cast iron shell.

⁵⁾ Not applicable to the FS80~100 flange mounted motors.

选件 Options

电动机订货号 Motor order code	选件号 ¹⁾ Option Code	描述 Description	应用范围 Application Scope
机械设计和防护等级 Mechanical design and degrees of protection			
—	X17 ⁸⁾⁹⁾	第二标准轴伸 Second standard shaft extension	FS80 ~ 355
—	P80 ¹⁰⁾	全圆法兰 Full circle flange	FS80 ~ 315
—	L04	光轴设计, 不带键槽和键 Shaft without key and keyway	FS80 ~ 355
—	H22	IP56 防护等级 (非高海况) IP56 degree of protection (non-heavy-sea)	FS80 ~ 355
—	H20	IP65 防护等级 (非高海况) IP65 degree of protection (non-heavy-sea)	FS80 ~ 355
—	L82 ¹¹⁾	驱动端轴带螺纹孔 DE shaft with threaded hole	FS80 ~ 355
—	H00 ¹²⁾	电动机带防护罩 Motor with protective cover	FS80 ~ 355
—	H03 ¹³⁾	排水孔 Drainage holes	FS80 ~ 355
—	F90 ¹⁴⁾	风机电机 (无风扇风罩, 非驱动端全封闭) Fan motor(no fan cover, NDE fully enclosed)	FS80 ~ 355
—	D03	用于环境温度 -40 °C ~ +40 °C 下使用的电机 Applicable to the motors that is used in the coolant temperature of -40°C~+40°C	FS80 ~ 355
—	X50 ¹⁵⁾	安装欧姆龙编码器 (E6B2-CWZ6C-1024) 和独立驱动风扇 Install OMRON encoder (E6B2-CWZ6C-1024) and independent drive fan	FS80 ~ 355
—	X59	预留安装 E6B2-C/TRD-2T 编码器位置 Prepared for of E6B2-C/TRD-2T encoder	FS80 ~ 355
—	F01 ¹⁹⁾	安装电磁制动器 Install the electro-magnetic brake	FS80 ~ 225
—	W74 ¹⁶⁾	安装欧姆龙编码器 (E6B2-CWZ1X-1024) 和独立驱动风扇 Install the OMRON encoder(E6B2-CWZ1X-1024) and independent drive fan	FS80 ~ 355
—	F70 ¹²⁾	电动机带独立驱动风扇 Motors with the independent drive fan	FS80 ~ 355

⁶⁾ 不适用于顶出线;

⁷⁾ 铸铁机座电机不含 160 机座号;

⁸⁾ H00、F70 均不能与此选件并用;

⁹⁾ 非驱动端上的第二轴伸尺寸见外形尺寸;

¹⁰⁾ 对于机座号为 180、200、225 和 280 的电动机不适用, 这些机座号的电动机标配的法兰为全圆法兰;

¹¹⁾ 螺纹孔尺寸参见“外形尺寸”部分中 DB 尺寸;

¹²⁾ 无法与选件号 X17 并用;

¹³⁾ 仅适用于水平安装的电动机。对于 IM B5 和 IM B14 安装结构型式的电动机, 选择此选件时, 必须确保接线盒处于机座顶端。对于其它安装结构型式的电机请咨询茵梦达;

⁶⁾ Not applicable to the outlet on top.

⁷⁾ Cast iron motor exclude FS160.

⁸⁾ H00、F70 can't be used with this option.

⁹⁾ Second standard shaft extension on NDE is shown in the dimension drawings.

¹⁰⁾ Not applicable to the FS180、200、225 and 280 motors, these motors include the full circle flange.

¹¹⁾ Threaded hole size is shown in the DB size of the section of dimension drawings.

¹²⁾ Unable to be used with the option X17.

¹³⁾ Only applicable to the vertical mounting motors. For the construction type of IM B5 and IM B14, when choose this option, it is necessary to ensure the connection box is on top of the frame. For other construction types, please specially consult with INNOMOTICS.

电动机订货号 Motor order code	选件号 ¹⁾ Option Code	描述 Description	应用范围 Application Scope
铭牌和测试证书 Rating plate and test certificates			
—	B80	出厂检验报告 Acceptance test certificate 3.1 in accordance with EN 10204	FS80 ~ 355
喷漆 Paint finish			
—	S01	不喷漆, 只带底漆 Unpainted, only primed	FS80 ~ 355
—	W88	适用 TH, W, F1, WF1 以及海洋性气候环境用电机 Design for TH, W, F1, WF1 and Sea air resistant	FS80 ~ 355
—	W9P	能效标签及合格证不贴, 随机带走 CEL label and quality certificate not pasted, delivered with motors	FS80 ~ 355
包装 Packing			
—	B90	包装 (FS80 ~ 132 电动机采用纸箱包装, FS160 ~ 355 电动机采用木箱包装) Packing (FS80~132 motors adopt the carton packaging, FS160~355 motors adopt the wooden cases packaging)	FS80 ~ 355
—	V9N	法兰安装电机用简易托盘 Simple tray for flange mounted motors	FS160 ~ 280

¹⁴⁾ 无风扇和风罩时, 电动机的长度将减小 Δl 。如需要按照铭牌上功率数值输出时电动机需要外部冷却。客户应当采用正确的冷却方式, 没有或错误的冷却方式都将减少电动机的使用寿命, 甚至会损坏电动机;

¹⁵⁾ SINAMICS 变频器联结 Omron 编码器 (E6B2-CWZ6C) 时, 变频器需要一些特殊配置。详细信息, 请咨询茵梦达热线;

¹⁶⁾ SINAMICS 变频器可以直接与 Omron 编码器 (E6B2-CWZ1X) 联结;

¹⁷⁾ 根据国标要求, 60Hz 频率下不考核能效要求;

¹⁸⁾ 不适用于 F70 和 F90 选件;

¹⁹⁾ 此制动器不可与 X50, X59 及 W74 中的编码器同时选用。若电机输入变频电源, 整流器需单独接工频电源。请在配置该选件时注明电机变频使用。接线盒将单独为整流器引接线配置进线葛兰孔, 详细信息, 请咨询茵梦达热线;

²⁰⁾ L51 在 280 机座, 非驱动端轴承型号为 6316, 在 355 机座 4/6/8 极, 非驱动端轴承型号将变为 6320。

¹⁴⁾ When without the fans or the shells, the motor length will be decreased by Δl . If it is necessary to output according to the nameplate power, the motor requires external cooling. Customers are supposed to adopt the right cooling method, without or wrong cooling methods will decrease the service life for the motors. even damage the motors.

¹⁵⁾ When the SINAMICS frequency converter is coupled with the Omron encoder(E6B2-CWZ6C), the frequency converter requires some special configuration. For more information, please consult the INNOMOTICS hotline.

¹⁶⁾ SINAMICS frequency converter can be directly coupled with the Omron encoder(E6B2-CWZ1X).

¹⁷⁾ According to the requirements of the GB, the energy efficiency requirement is not evaluated under the frequency of 60Hz.

¹⁸⁾ Not suitable for F70 and F90.

¹⁹⁾ This type electro-magnetic brake can't be configure together with pulse encode in option X50, X59 and W74. In VSD application, rectifier should connect to DOL course separately. Please give indication of VSD application when selecting this option. There will be a separate cable gland for rectifier. For details please contact Innomotics.

²⁰⁾ L51 NDE bearing is 6316 on FS280, 6320 on FS355 4/6/8 poles.

外形尺寸 Dimension drawings

1TL0001 铸铁系列电动机 Cast-iron series 1TL0001

机座号 80M 至 355L Frame sizes 80M to 355L

IM B3 安装结构型式 Type of construction IM B3

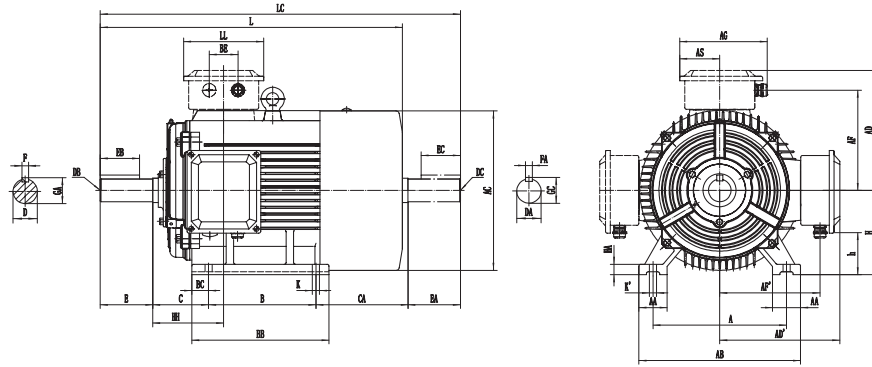

IM B35 安装结构型式 Type of construction IM B35

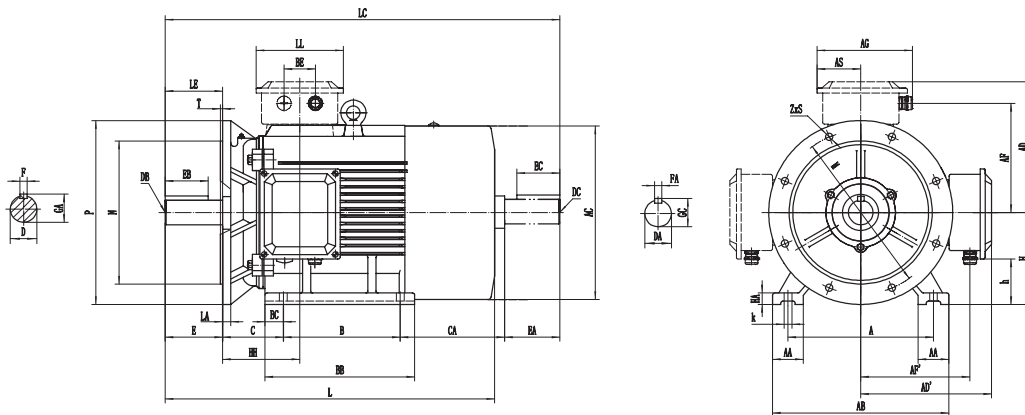

机座号 Frame size	类型 Type 1TL0001-	极数 Poles	尺寸图依据 IEC 标准 Dimension designation according to IEC standards																			
			A	AA	AB	AC	AD/AD'	AF/AF'	AG	AH	AS	B ¹⁾	BB	BC	BE	C ²⁾	CA	H	h	HA	HH ³⁾ Top	HH ³⁾ RHS
80 M	0D □ 2	2,4,6	125	34	160	161	145	111	130	—	52	100	130	15	⁻³⁾ 50	108	80	29	10	72	100	
	0D □ 3		125	34	160	161	145	111	130	—	52	100	130	15	⁻³⁾ 50	108	80	29	10	72	100	
90 S	0E □ 0	2,4,6	140	36	180	175	160	121	135	—	55	100	140	20	⁻³⁾ 56	119	90	35	12	75	106	
	0E □ 4		140	36	180	175	160	121	135	—	55	125	165	20	⁻³⁾ 56	119	90	35	12	75	119	
100 L	1A □ 4	2,4,6	160	40	200	196	165	140	135	—	55	140	188	24	⁻³⁾ 63	128	100	45	14	77	133	
	1A □ 5		160	40	200	196	165	140	135	—	55	140	188	24	⁻³⁾ 63	128	100	45	14	77	133	
112 M	1B □ 2	2,4,6	190	45	226	217	193	152	155	—	64	140	180	20	42	70	135	112	48	15	87	140
132 S	1C □ 0	2,4,6,8	216	55	262	258	203	175	155	—	64	140	186	23	42	89	168	132	68	18	99	159
	1C □ 1		2	216	55	262	258	203	175	155	—	64	140	186	23	42	89	168	132	68	18	99
132 M	1C □ 2	4,6,8	216	55	262	258	203	175	155	—	64	178	224	23	42	89	170	132	68	18	99	178
	1C □ 3		6	216	55	262	258	203	175	155	—	64	178	224	23	42	89	170	132	68	18	99
160 M	1D □ 2	2,4,6,8	254	65	314	311	255	206	200	480	83	210	260	25	60	108	189	160	77	20	150	213
	1D □ 3		2,8	254	65	314	311	255	206	200	480	83	210	260	25	60	108	189	160	77	20	150
160 L	1D □ 4	2,4,6,8	254	65	314	311	255	206	200	480	83	254	304	25	60	108	190	160	77	20	150	150
180M	1E □ 2	2,4	279	70	349	356	280	221	200	480	83	241	309	35	60	121	226	180	97	22	161	161
180L	1E □ 4	4,6,8	279	70	349	356	280	221	200	480	83	279	344	35	60	121	223	180	97	22	161	161
200L	2A □ 4	2,6	318	70	388	398	310	248	250	575	107	305	379	32	72	133	242	200	94	25	186	186
	2A □ 5		2,4,6,8	318	70	388	398	310	248	250	575	107	305	379	32	72	133	242	200	94	25	186
225S	2B □ 0	4,8	356	75	431	428	325	257	250	600	107	286	366	45	72	149	245	225	119	28	189	189
225M	2B □ 2	2	356	75	431	428	325	257	250	600	107	311	391	45	72	149	245	225	119	28	189	189
		4,6,8																				

¹⁾ 该尺寸为 DIN EN 50347 标准所列机座号对应尺寸。 ²⁾ 1TL0001 电机配置 L82 选件时，螺纹孔的尺寸。

³⁾ 当特殊设计为接线盒在非驱动端时，电机安装等相关尺寸会发生变化，具体请咨询茵梦达。

备注：适用于 60Hz 电机，F70 长度增量请参考独立驱动风扇技术参数表中 ΔL，F90 电机尺寸减少的量请参考 ΔI。

IM B5 以及 IM V1 安装结构型式 Type of construction IM B5 and IM V1

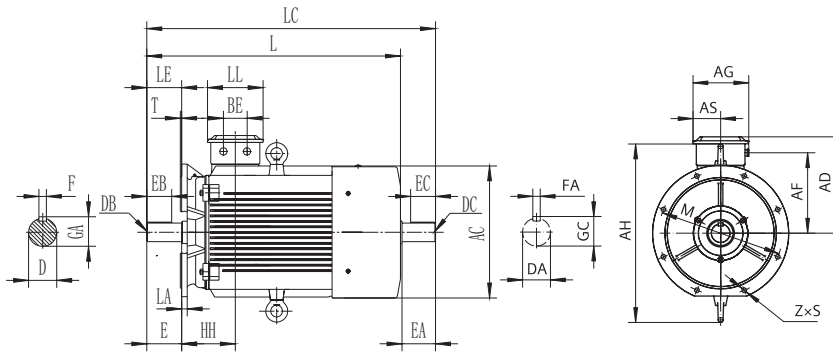

IM B14 安装结构型式 Type of construction IM B14

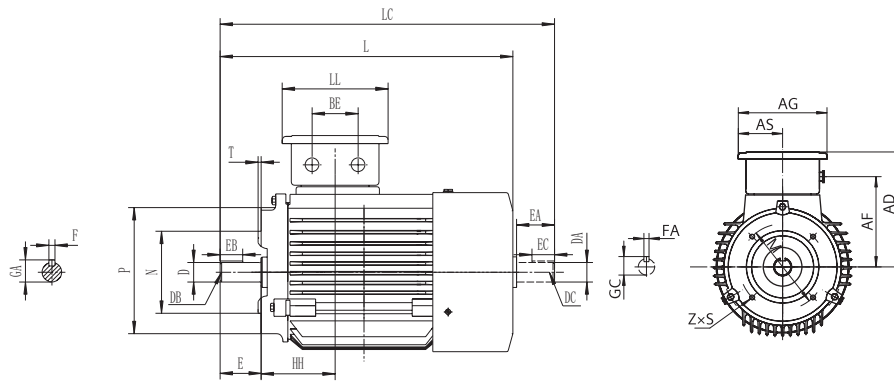

机座号 Frame size	类型 Type 1TL0001-	极数 Poles	尺寸图依据 IEC 标准 Dimension designation according to IEC standards																
			HH ³⁾	LHS	K/K'	L	LC	LL	D	DB ²⁾	E	EB	F	GA	DC	DA	EA	EC	FA
80 M	0D □ 2	2,4,6	100	10	290	338	103	19	M6x16	40	22	6	21.5	M6x16	19	40	22	6	21.5
	0D □ 3		100	10	290	338	103	19	M6x16	40	22	6	21.5	M6x16	19	40	22	6	21.5
90 S	0E □ 0	2,4,6	106	10	320	375	110	24	M8x19	50	32	8	27	M8x19	24	50	32	8	27
	0E □ 4		119	10	345	400	110	24	M8x19	50	32	8	27	M8x19	24	50	32	8	27
100 L	1A □ 4	2,4,6	133	12	385	451	110	28	M10x22	60	40	8	31	M10x22	28	60	40	8	31
	1A □ 5		133	12	385	451	110	28	M10x22	60	40	8	31	M10x22	28	60	40	8	31
112 M	1B □ 2	2,4,6	140	12	400	465	119	28	M10x22	60	40	8	31	M10x22	28	60	40	8	31
132 S	1C □ 0	2,4,6,8	159	12	470	557	119	38	M12x28	80	56	10	41	M12x28	38	80	56	10	41
	1C □ 1		2	159	12	470	557	119	38	M12x28	80	56	10	41	M12x28	38	80	56	10
132 M	1C □ 2	4,6,8	178	12	510	597	119	38	M12x28	80	56	10	41	M12x28	38	80	56	10	41
	1C □ 3		6	178	12	510	597	119	38	M12x28	80	56	10	41	M12x28	38	80	56	10
160 M	1D □ 2	2,4,6,8	213	15	615	727	157	42	M16x36	110	80	12	45	M16x36	42	110	80	12	45
	1D □ 3		213	15	615	727	157	42	M16x36	110	80	12	45	M16x36	42	110	80	12	45
160 L	1D □ 4	2,4,6,8	320	15	660	772	157	42	M16x36	110	80	12	45	M16x36	42	110	80	12	45
180M	1E □ 2	2,4	326	15	695	808	157	48	M16x36	110	80	14	51.5	M16x36	48	110	80	14	51.5
180L	1E □ 4	4,6,8	361	15	730	843	157	48	M16x36	110	80	14	51.5	M16x36	48	110	80	14	51.5
200L	2A □ 4	2,6	395	19	785	900	197	55	M20x42	110	80	16	59	M20x42	55	110	80	16	59
	2A □ 5		2,4,6,8	395	19	785	900	197	55	M20x42	110	80	16	59	M20x42	55	110	80	16
225S	2B □ 0	4,8	384	19	810	960	197	60	M20x42	140	100	18	64	M20x42	60	140	100	18	64
225M	2B □ 2	2	409	19	805	925	197	55	M20x42	110	80	16	59	M20x42	55	110	80	16	59
			4,6,8	835	985	60	140	100	18	64	60	140	100	18	64				

¹⁾ he dimension corresponds to the dimension that listed in the DIN 50347 Standard; ²⁾ When the 1TL0001 motors are equipped with the L82 option, the thread hole size.
³⁾ When terminal box special designed at the non drive end, the dimension related to motor installation may change, for more information, please consult the INNOMOTICS.

Note: Suitable for 60Hz motor, dimension increase for F70, please refer to ΔL in technical data for separately fan, the length decrease for F90 please refer to ΔL.

外形尺寸 Dimension drawings

1TL0001 铸铁系列电动机 Cast-iron series 1TL0001

机座号 80M 至 355L Frame sizes 80M to 355L

IM B3 安装结构型式 Type of construction IM B3

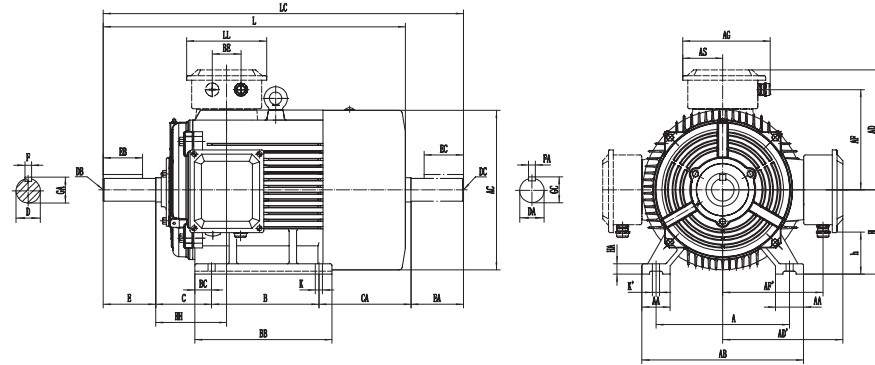

IM B35 安装结构型式 Type of construction IM B35

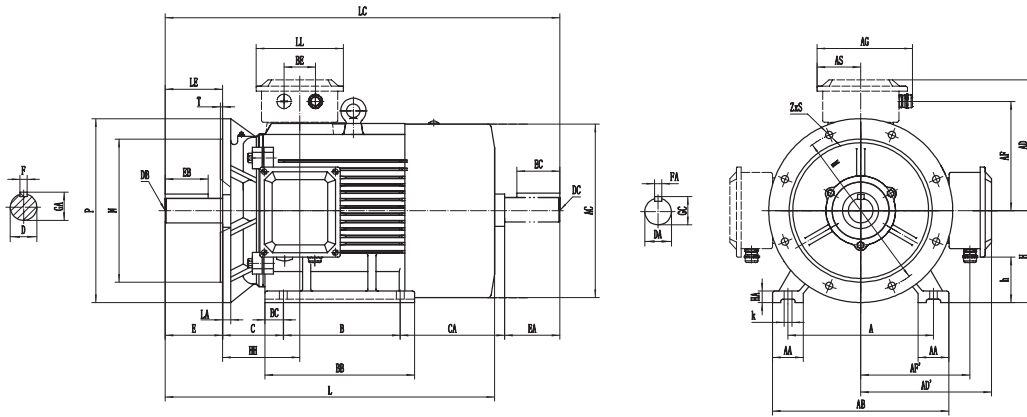

机座号 Frame size	类型 Type 1TL0001-	极数 Poles	尺寸图依据 IEC 标准 Dimension designation according to IEC standards																				
			A	AA	AB	AC	AD/AD'	AF/AF'	AG	AH	AS	B ¹⁾	BB	BC	BE	C ³⁾	CA	H	h	HA	HH ³⁾ Top	HH ³⁾ RHS	
250M	2C □ 2	2	406	80	484	475	360	311	295	670	124	349	425	40	80	168	203	250	126	30	222	222	
		4,6,8																					
280S	2D □ 0	2	457	85	542	530	395	351	295	755	124	368	485	74	80	190	77	280	156	35	216	216	
		4,6,8																					
280M	2D □ 2	2	457	85	542	530	395	351	295	755	124	419	536	74	80	190	281	280	156	35	216	216	
		4,6,8																					
315S	3A □ 0	2	508	120	628	581	505	401	385	920	171	406	540	84	120	216	370	315	155	45	258	258	
		4,6,8																					
315M	3A □ 2	2	508	120	628	581	505	401	385	920	171	457	680	84	120	216	499	315	155	45	258	258	
		4,6,8																					
315L	3A □ 5/3A □ 6/ 3A □ 7	2	508	120	628	581	505	401	385	920	171	508	680	84	120	216	448	315	155	45	258	258	
		4,6,8																					
355M	3B □ 2	2	610	120	730	698	630	516	454	1138	181	560	750	68	125	254	548	355	136	53	281	281	
		4,6,8																					
		2	610	120	730	698	630	516	454	1138	181	560	750	68	125	254	548	355	136	53	281	281	
355L	3B □ 4	6	610	120	730	698	630	516	454	1138	181	630	750	68	125	254	478	355	136	53	281	281	
		2	610	120	730	698	630	516	454	1138	181	630	750	68	125	254	478	355	136	53	281	281	
		4,6,8																					
355L	3B □ 5	2	610	120	730	698	630	516	454	1138	181	630	750	68	125	254	478	355	136	53	281	281	
		4,6,8																					
355L	3B □ 6	2	610	120	730	698	630	516	454	1138	181	630	750	68	125	254	478	355	136	53	281	281	
		4,6,8																					

¹⁾ 该尺寸为 DIN EN 50347 标准所列机座号对应尺寸。 ²⁾ 1TL0001 电机配置 L82 选项时，螺纹孔的尺寸。

³⁾ 当特殊设计为接线盒在非驱动端时，电机安装等相关尺寸会发生变化，具体请咨询茵梦达。

备注：适用于 60Hz 电机，F70 长度增量请参考独立驱动风扇技术参数表中 ΔL，F90 电机尺寸减少的量请参考 ΔI。

IM B5 以及 IM V1 安装结构型式 Type of construction IM B5 and IM V1

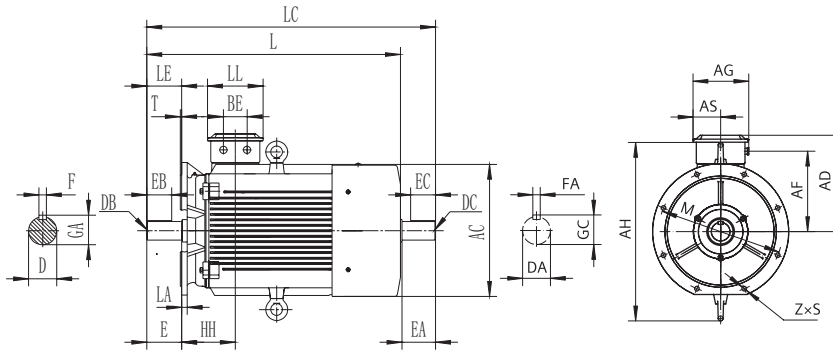

机座号 Frame size	类型 Type 1TL0001-	极数 Poles	尺寸图依据 IEC 标准 Dimension designation according to IEC standards																
			HH ¹⁾	LHS	K/K'	L	LC	LL	D	DB ²⁾	E	EB	F	GA	DC	DA	EA	EC	FA
250M	2C □ 2	2	222	24/40	855	1005	224	60	M20x42	140	100	18	64	M20x42	60	140	100	18	64
		4,6,8			1005	65							69	65					69
280S	2D □ 0	2	216	24	910	1060	224	65	M20x42	140	100	18	69	M20x42	65	140	100	18	69
		4,6,8			75							20	79	75				20	79
280M	2D □ 2	2	216	24	1020	1170	224	65	M20x42	140	100	18	69	M20x42	65	140	100	18	69
		4,6,8			75							20	79	75				20	79
315S	3A □ 0	2	258	28	1125	1272	310	65	M20x42	140	100	18	69	M20x42	65	140	100	18	69
		4,6,8			1155	1332	80					22	85	80	170	130	22	85	
315M	3A □ 2	2	258	28	1305	1452	310	65	M20x42	140	100	18	69	M20x42	65	140	100	18	69
		4,6,8			1335	1512	80					22	85	80	170	130	22	85	
315L	3A □ 5/3A □ 6/ 3A □ 7	2	258	28	1305	1452	310	65	M20x42	140	100	18	69	M20x42	65	140	100	18	69
		4,6,8			1335	1512	80					22	85	80	170	130	22	85	
355M	3B □ 2	2	281	28	1490	1642	362	75	M20x42	140	125	20	79.5	M20x42	75	140	125	20	79.5
		4,6,8			1520	1702	95	M24x50	170	140	25	100	M24x50	95	170	140	25	100	
	3B □ 3	2	281	28	1490	1642	362	75	M20x42	140	125	20	79.5	M20x42	75	140	125	20	79.5
		4,6,8			1520	1702	95	M24x50	170	140	25	100	M24x50	95	170	140	25	100	
355L	3B □ 4	6	281	28	1520	1702	362	95	M24x50	170	140	25	100	M24x50	95	170	140	25	100
		2	281	28	1490	1642	362	75	M20x42	140	125	20	79.5	M20x42	75	140	125	20	79.5
	3B □ 5	2	281	28	1490	1642	362	75	M20x42	140	125	20	79.5	M20x42	75	140	125	20	79.5
		4,6,8			1520	1702	95	M24x50	170	140	25	100	M24x50	95	170	140	25	100	
3B □ 6	2	281	28	1490	1642	362	75	M20x42	140	125	20	79.5	M20x42	75	140	125	20	79.5	
	4,6,8			1520	1702	95	M24x50	170	140	25	100	M24x50	95	170	140	25	100		

¹⁾ he dimension corresponds to the dimension that listed in the DIN 50347 Standard; ²⁾ When the 1TL0001 motors are equipped with the L82 option, the thread hole size.
³⁾ When terminal box special designed at the non drive end, the dimension related to motor installation may change, for more information, please consult the INNOMOTICS.

Note: Suitable for 60Hz motor, dimension increase for F70, please refer to ΔL in technical data for separately fan, the length decrease for F90 please refer to ΔL.

外形尺寸 Dimension drawings

法兰尺寸 Flange dimension

IM B5、IM B35、IM V1、IM V3 安装结构型式 Type of construction IM B5, IM B35, IM V1, IM V3

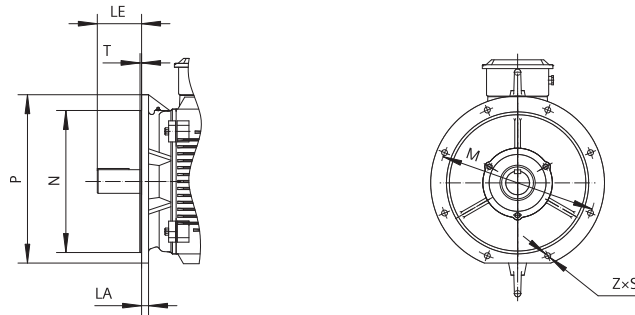

机座号 Frame size	安装结构形式 Type of construction	法兰带通孔 (FF / A) / 法兰带内螺纹孔 (FT / C) Flange with through holes (FF/A) / tapped holes (FT/C)
		按 DIN / EN 50 347 标准 According to DIN EN 50347
80	IM B5, IM B35, IMV1, IM V3	FF 165
	IM B14, IM V18, IM V19	FT 100
90	IM B5, IM B35, IMV1, IM V3	FF 165
	IM B14, IM V18, IM V19	FT 115
100	IM B5, IM B35, IMV1, IM V3	FF 215
	IM B14, IM V18, IM V19	FT 130
112	IM B5, IM B35, IMV1, IM V3	FF 215
	IM B14, IM V18, IM V19	FT 130
132	IM B5, IM B35, IMV1, IM V3	FF 265
160	IM B5, IM B35, IMV1, IM V3	FF 300
180	IM B5, IM B35, IMV1, IM V3	FF 300
200	IM B5, IM B35, IMV1, IM V3	FF 350
225	IM B5, IM B35, IMV1, IM V3	FF 400
250	IM B5, IM B35, IMV1, IM V3	FF 500
280	IM B5, IM B35, IMV1, IM V3	FF 500
315	IM B5, IM B35, IMV1, IM V3	FF 600
355	IM B5, IM B35, IMV1, IM V3	FF 740

法兰尺寸 Flange dimension

IM B14、IM V18、IM V19 安装结构型式 Type of construction IM B14, IM V18, IM V19

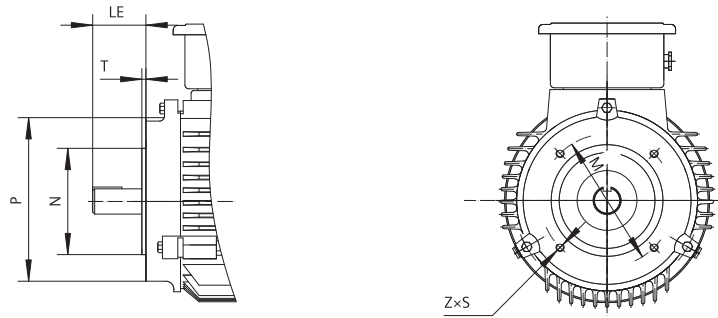

机座号 Frame size	尺寸图依据 Dimension designation according to IEC standards							
	LA	LE	M	N	P	S	T	Z
80	12	40	165	130	200	12	3.5	4
	—	40	100	80	120	M 6	3	4
90	12	50	165	130	200	12	3.5	4
	—	50	115	95	140	M 8	3	4
100	13	60	215	180	250	14.5	4	4
	—	60	130	110	160	M 8	3.5	4
112	14	60	215	180	250	14.5	4	4
	—	60	130	110	160	M 8	3.5	4
132	14	80	265	230	300	14.5	4	4
160	14	110	300	250	350	18.5	5	4
180	15	110	300	250	350	18.5	5	4
200	17	110	350	300	400	18.5	5	4
225	20	110 / 140	400	350	450	18.5	5	8
250	22	140	500	450	550	18.5	5	8
280	22	140	500	450	550	18.5	5	8
315	22	140 / 170	600	550	660	24	6	8
355	25	140 / 170	740	680	800	24	6	8

茵梦达电机（中国）有限公司

地址：江苏省仪征市汽车工业园众鑫路99号

电话：+86 514 85718108

传真：+86 514 85718083

邮编：211400

邮箱：motorservice.ssml.cn@innomotics.com

网址：www.beide-motor.cn

茵梦达电机（中国）有限公司版权所有，如有改动恕不事先通知。